

# Application Note

## Impedance Matching for Near Field Communication Applications



ANP084 // CHRISTIAN MERZ / CEM SOM

### 1 Introduction

The number of mobile devices on the market equipped with NFC (Near Field Communication) or RFID (Radio Frequency Identification) technology is increasing exponentially. NFC is a short range, high frequency, low bandwidth wireless communication technology, which enables a standardized communication between two mobile devices like smartphones, smart cards, stickers or tags. NFC and RFID use the same frequency, 13.56 MHz. While RFID is capable of reception and transmission up to several meters, NFC is restricted to very close proximity, less than 10 cm, and is extensively used in NFC tags, data communications, and secure financial transactions. Würth Elektronik already offers a broad portfolio of **WPT coils** (Wireless Power Transfer). As a further innovation, winding an NFC antenna around a WPT coil enables a new communication channel between WPT transmitter and receiver, which can be used for system control and data transfer. With NFC, data rates of up to 848 kbit/s can be achieved. The **WE-WPCG WPT/NFC** series combines a WPT coil and an NFC antenna in one efficient component. For the system designer this combination of WPT and NFC coils in a single component has advantages in terms of simplicity, efficient form factor and cost. In this application note we show how the impedance of the NFC antenna can be matched to the integrated NFC circuit IC to maximize the radiated field and transmission distance [3]. As an example we have used the WPT combination coil **760308101312** from Würth Elektronik but the technique applies to any NFC antenna.

WE currently offers five different WPT/NFC combination coils, as shown in table 1.  $L_1$  and  $Q_1$  are measured at 125 kHz and  $L_2$  and  $Q_2$  are measured at 13.56 MHz.

Part number	WPT		NFC	
	$L_1$ ( $\mu\text{H}$ )	$Q_1$	$L_2$ ( $\mu\text{H}$ )	$Q_2$
<b>760308101150</b>	6.3	100	1.2	80
<b>760308103305</b>	8.8	30	1.4	47
<b>760308102306</b>	8	19	1.4	47
<b>760308103307</b>	7.8	19	1.6	47
<b>760308101312</b>	24	125	0.7	30

Table 1: WE WPT/NFC combination coils

### 2 Complex conjugate impedance matching

#### 2.1 Basics

Conjugate complex impedance matching is a very important procedure in RF circuit design to provide the maximum possible power transfer between a source and its load and to minimize the signal reflections from the load. One example for the need of power transfer occurs in the front end of any sensitive receiver. Obviously, any unnecessary loss in a circuit that is already carrying extremely small signal levels simply cannot be tolerated. Therefore, in most instances, extreme care is taken during the initial design of such a front end to make sure that each device in the chain is matched to its load. [1] In RF technology, loads are often complex, i.e. they have an inductive or capacitive component in addition to their resistive part. For matching, the inductive or capacitive component must be compensated with its counterpart, the so-called complex conjugate component. This means for example that an inductive component must be capacitively compensated. Impedance matching is based on the maximum power transfer theorem. It states that, to obtain maximum external power from a source with a finite internal resistance, the resistance of the load must be equal to the resistance of the source as seen from its output terminals. Additionally, it states that any reactive component of the source and load should be of equal magnitude but opposite sign. This means that the load and source impedances have to be complex conjugate to each other. [2]

In general, the complex conjugate of the impedance  $Z = R + jX$  is  $Z^* = R - jX$ , where  $R$  is the real part and  $X$  is the imaginary part of the complex impedance  $Z$ . Figure 1 shows the complex source impedance  $Z_s$  and the complex load impedance  $Z_L$ .

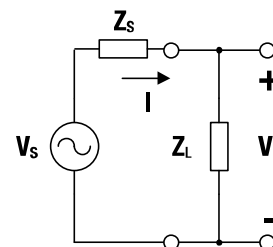

Figure 1: Source and load impedance [2]

# Application Note

## Impedance Matching for Near Field Communication Applications



These impedances have to fulfill the following condition, to lead to an optimal match:

$$Z_L = Z_S^* \quad (1)$$

There are many possible network topologies that could be used to perform the impedance reactances. Among them, the simplest one is the L-topology, which comprises of two elements and gets its name from the component orientation, which resembles the shape of an L. [1] Figure 2 shows the two possible implementations of the L-topologies for impedance matching.

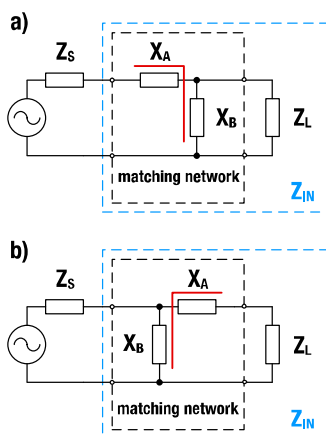

Figure 2: L-topology matching networks

In figure 2,  $X_A$  is the ideal reactance of the series leg and  $X_B$  is the ideal reactance of the parallel leg.  $Z_S$  and  $Z_L$  are the source and load impedances.  $Z_{in}$  denotes the input impedance and includes the load and matching impedance, which has to be the complex conjugate of  $Z_S$ . Before the matching components can be determined, the load and source impedances have to be known. The source impedance is in most cases  $50 \Omega$ . In general, the source impedance can also be complex.

For higher frequencies in the UHF band (e.g. 434 MHz, 868 MHz and 2.4 GHz), the matching process is described in the Application Note [ANP057](#). Würth Elektronik also offers a customer [antenna matching service](#) for these frequencies.

### 2.2 Determination of the complex load impedance

The complex load impedance can be determined by measurement and calculation. The complex impedance measurement for the 13.56 MHz range can be done with a vector network analyzer, which measures the S-parameter of the device under test. S-parameters describe the electrical behavior of linear electrical networks when undergoing various steady state stimuli by electrical signals. For impedance matching, the  $S_{11}$  parameter, which is called input port voltage reflection coefficient, is used. The input port voltage reflection coefficient is a complex quantity, whose absolute value is an indicator for the reflection.  $|S_{11}| = 0$  means that the circuit is perfectly matched and that none of the incident power wave is

reflected.  $|S_{11}| = 1$  denotes that 100% of the incident power wave is reflected back to the input. For NFC applications, the load is an antenna. For practical calculations and simulations, the electrical properties of the antenna are represented in an equivalent circuit. The simplified series equivalent circuit of an NFC antenna is shown in figure 3.

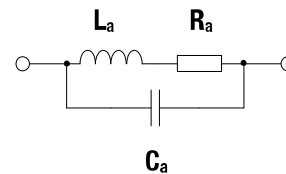

Figure 3: Simplified series equivalent circuit of an NFC antenna

$L_a$  is the inductance and  $R_a$  is the equivalent series resistance, which represents all ohmic losses of the antenna.  $C_a$  is the parallel equivalent capacitance of the antenna. The values  $L_a$  and  $R_a$  can be directly measured with a network analyzer or LCR meter. The value  $C_a$  is a parasitic value and must be determined by measurement and calculation. The frequency dependencies of  $L_a$ ,  $C_a$  and  $R_a$  are not taken into account in the calculations and simulations. Knowing the inductance  $L_a$ , the parallel equivalent capacitance  $C_a$  can be calculated at the self resonance frequency  $f_s$  with equation (2). [8]

$$C_a = \frac{1}{(2 \cdot \pi \cdot f_s)^2 \cdot L_a} \quad (2)$$

The self-resonance frequency  $f_s$  can be measured as the first point where the complex load impedance becomes real.

The impedance of the antenna  $Z_L$ , which is necessary for the impedance matching, can be calculated as follows:

$$Z_L = \frac{R_a}{(1 - \omega^2 L_a C_a)^2 + (\omega R_a C_a)^2} + j \frac{\omega L_a - \omega^3 L_a^2 C_a - \omega R_a^2 C_a}{(1 - \omega^2 L_a C_a)^2 + (\omega R_a C_a)^2} \quad (3)$$

$$Z_L = R_L + jX_L$$

The quality factor  $Q_L$  of the antenna is defined by the relation of the imaginary part  $X_L$  and the real part  $R_L$  of the antenna impedance and can therefore be calculated with equation (4).

$$Q_L = \frac{\text{Im}(Z_L)}{\text{Re}(Z_L)} = \frac{X_L}{R_L} \quad (4)$$

### 2.3 Determination of the matching circuit components

The matching procedure can be performed by calculation and simulation. In general, both impedance networks shown in figure 2 can be used, but the network shown in figure 2a is easier to calculate and has been chosen to demonstrate the matching procedure. Because the load has an inductive behavior, the reactances  $X_A$  and  $X_B$  are capacitive. In general,  $X_A$  and  $X_B$  can also be inductive if the load has a capacitive behavior.  $X_A$  and  $X_B$  are considered to be ideal, which means that they are considered to have no resistive or parasitic part.

# Application Note

## Impedance Matching for Near Field Communication Applications



### 2.4 Calculation of the matching circuit components

For the network shown in figure 2a, the perfect match is achieved for  $Z_{in} = Z_S^*$ , and  $Z_{in}$  can be calculated as follows [5]:

$$Z_{in} = R_{in} + jX_{in} = Z_S^* = R_S - jX_S$$

$$Z_{in} = jX_A + \frac{jR_L^2 X_B + R_L X_B^2 + jX_L^2 X_B + jX_L X_B^2}{R_L^2 + (X_L + X_B)^2} \quad (5)$$

Due to equation (5), the real and imaginary part of the input impedance  $Z_{in}$  are:

$$\text{Re}(Z_{in}) = R_S = \frac{R_L X_B^2}{R_L^2 + (X_L + X_B)^2} \quad (6)$$

$$\text{Im}(Z_{in}) = -X_S = X_A + \frac{R_L^2 X_B + X_L^2 X_B + X_L X_B^2}{R_L^2 + (X_L + X_B)^2} \quad (7)$$

If the equation (6) is solved for the reactance  $X_B$ , we get two different values  $X_{B1}$  and  $X_{B2}$  because (6) is a quadratic equation:

$$X_{B1,2} = \frac{R_S}{R_L - R_S} \cdot \left( X_L \pm R_L \cdot \sqrt{\frac{R_L}{R_S} + \frac{X_L^2}{R_S R_L} - 1} \right) \quad (8)$$

The reactance  $X_A$  also has two values,  $X_{A1}$  and  $X_{A2}$ , and results due to equation (7) into the following expression, taking equation (8) into account:

$$X_{A1,2} = -X_S - X_{B1,2} \cdot \frac{R_L^2 + X_L^2 + X_L X_{B1,2}}{R_L^2 + (X_L + X_{B1,2})^2} \quad (9)$$

The influence of each capacitance on the impedance  $Z_{in}$  can be investigated separately with equations (8) and (9).

The series capacitor  $C_A$  can only add a reactive (imaginary) part from the network impedance  $Z_{in}$ . The parallel capacitor  $C_B$  is needed to adjust the real impedance to the desired value and yield to a circular curve in the complex plane. The influences of the two capacitors in the network impedance is illustrated with the locus curve in figure 4. Because the mathematical way of determining the matching component values can get very complicated, especially for three components matching, the way of simulation is preferred.

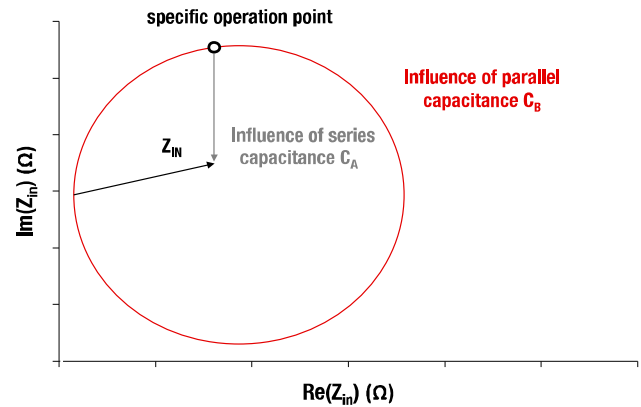

Figure 4: Influence of parallel and the series capacitance  $C_A$  and  $C_B$  on the network impedance  $Z_{in}$  [5]

### 2.5 Simulation of the matching circuit components

In the field of RF circuit simulation, the software Keysight Advanced Design System (ADS) is the de facto standard. For the determination of the matching components, the ADS optimization tool is recommended to be used. The optimization tool is an automated procedure of achieving the circuit performance in which ADS can modify circuit component values to meet a defined optimization goal. The goal is in this case to minimize the parameter  $S_{11}$  by modifying the matching components until the input impedance comprises a complex conjugate of the source impedance. To determine the matching components using the optimization tool and calculation, an example of the complete matching procedure is performed in the next sections. A simplified filter and matching network with L-topology with two capacitors as reactive elements and the equivalent circuit of an antenna as a load is simulated with ADS and the matching components are determined by simulation and calculated using the equations (8) and (9). The calculated and simulated matching components will be compared afterwards.

## 3 Application of the impedance matching on an output NFC circuit

### 3.1 Setup of a typical NFC output circuit

An NFC IC normally has a differential output and has an impedance of  $50 \Omega$  between the output pins  $TX_1$  and  $TX_2$ . These pins are connected with an output circuit comprising of a filter network, a matching circuit, damping resistors and an NFC antenna. The output of the NFC IC is differential to be resistant against electromagnetic noise. A typical differential NFC output circuit is shown in figure 5.

# Application Note

## Impedance Matching for Near Field Communication Applications

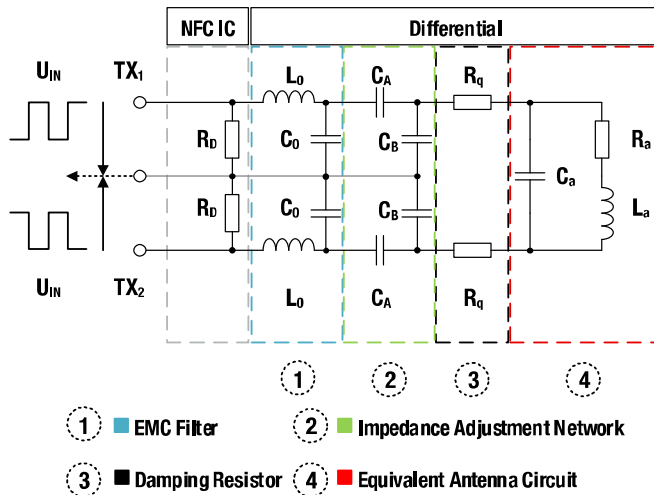

Figure 5: Differential output NFC circuit [5]

To simplify the understanding of the output NFC circuit components the differential circuit has to be transformed to a single ended one. Equations (8) and (9) can be applied to calculate the matching capacitors  $C_A$  and  $C_B$ . The transformation calculations are performed in [6] and the resulting single ended circuit is shown in figure 6.

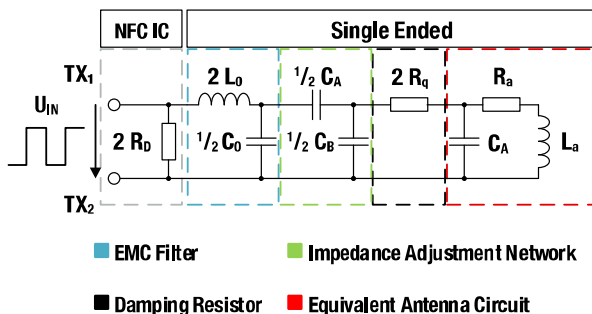

Figure 6: Equivalent single ended output NFC circuit [5]

### 3.2 EMC filter network

As the output signal of the NFC IC has a rectangular shape, the harmonics have to be filtered out. This is done by the EMC filter network, which is a second order low pass. The low pass filter comprises of the inductance  $L_0$  and the capacitance  $C_0$ .

The cutoff frequency  $f_c$  of the EMC filter can be calculated with equation (10).

$$f_c = \frac{1}{2 \cdot \pi \sqrt{L_0 \cdot C_0}} \quad (10)$$

The cutoff frequency  $f_c$  must be higher than the upper auxiliary carrier, which is  $13.56 \text{ MHz} + 848 \text{ kHz} = 14.4 \text{ MHz}$  for the highest possible NFC data rate of 848 kbit/s. A NFC load modulation spectra with carrier and auxiliary carriers is shown in figure 7 to visualize the necessity of the filter.

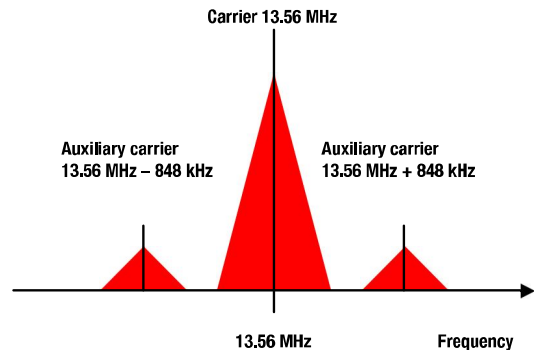

Figure 7: NFC load modulation spectra of carrier and auxiliary carriers [7]

For the impedance matching procedure, the impedance of the filter must be calculated using equation (11).

$$Z_{EMC} = \frac{2 R_D}{(1 - \omega^2 L_0 C_0)^2 + (\omega R_D C_0)^2} - j \frac{2 \omega^3 L_0^2 C_0 + 2 \omega R_D^2 C_0 - 2 \omega L_0}{(1 - \omega^2 L_0 C_0)^2 + (\omega R_D C_0)^2} \quad (11)$$

$$Z_{EMC} = R_{EMC} - jX_{EMC}$$

### 3.3 Impedance adjustment network

The matching circuit, also called an impedance adjustment network, shown in figures 5 and 6, has two purposes. The first is to compensate the inductive impedance of the antenna. The second is to provide the impedance transformation from the load impedance to the source impedance. For lossless transformation all components should be reactive elements. In a cost and space sensitive environment like NFC, it is desirable to keep the component count to a minimum, which is the reason to use a L matching topology.

### 3.4 Damping resistors and equivalent antenna circuit

The damping resistor  $R_q$  is an optional resistor, which can be used to reduce the Q factor of the antenna. Selecting the optimum value for  $R_q$  is a trade-off. On the one hand, a small value will increase the antenna efficiency of the contactless power transmission, on the other hand, a high resistor value will provide a higher bandwidth for the modulation and decrease the antenna Q factor. The recommended value range for the Q factor is between 20 and 35 as proposed in [8]. The resistor  $R_q$  should be integrated, if the Q factor of the antenna, which can be calculated with equation (4), exceeds the value of 35. If the value is higher, equation (4) has to be modified using equation (12). [5]

# Application Note

## Impedance Matching for Near Field Communication Applications



$$Q_{L,mod} = \frac{\text{Im}(Z_{L,mod})}{\text{Re}(Z_{L,mod})} = \frac{X_L}{2R_q + R_L} \quad (12)$$

This leads to the following formula to calculate the damping resistor value  $R_q$  (for  $Q_{L,mod} \geq 35$ ):

$$R_q = 0.5 \left( \frac{X_L}{Q_{L,mod}} - R_L \right) \quad (13)$$

The last part of the output network is the equivalent antenna network, which is described in section 2.2. This network has been utilized for the simulations and calculations of the load impedance.

### 3.5 Six Steps to match an NFC IC to a WE NFC antenna

As an example, it is described step by step how the NFC antenna of [760308101312](#) (see figure 8) can be matched to any arbitrary NFC IC with a differential output impedance of  $50 \Omega$  by calculation and simulation. The differential output circuit, shown in figure 5, has been used in the example.



**Figure 8: WE WPT/NFC combination transmitter coil 760308101312**

The following steps have to be performed, to implement the impedance matching by calculation and simulation:

1. Measure the series equivalent resistance  $R_a$  and the inductance  $L_a$  at the operating frequency  $f_{op} = 13.56$  MHz and the self resonance frequency  $f_s$  of the coil [760308101312](#) with a network analyzer. Calculation of the parallel capacitance  $C_a$  with equation (2) and determination of the equivalent antenna circuit (see figure 3).
2. The resulting values of  $R_a$ ,  $L_a$  and  $C_a$  have to be inserted into equation (3). The load impedance  $Z_L$  with real part  $R_L$  and imaginary part  $X_L$  has to be calculated. The Q factor has to be calculated with equation (4).
3. The capacitance  $C_0$  and the inductance  $L_0$  of the EMC filter network must be determined with equation (10) and inserted into equation (11), so that the complex impedance  $Z_{EMC}$  with real part  $R_{EMC}$  and imaginary part  $X_{EMC}$  can be calculated.
4. The values for  $R_L$ ,  $X_L$ ,  $R_{EMC}$  (denoted as  $R_S$  in equations (8) and (9)) and  $X_{EMC}$  (denoted as  $X_S$  in equations (8) and (9)) have to be integrated into the in equations (8) and (9). The capacitor values  $C_A$  and  $C_B$  have to be calculated out of  $X_A$  and  $X_B$ .

5. Verification of the matching calculation results by determining  $|S_{11}|$ .

6. Simulation of the  $S_{11}$  parameter of the differential output circuit (see figure 5) and comparison of the results with the calculation.

### 3.6 Determination of the equivalent antenna circuit

For the NFC antenna of article [760308101312](#) the following parameters have been determined by measurement and calculation:

Parameter	Value	Unit	Way of determination
$f_s$	63	MHz	Measurement with VNA
$L_a$	0.7	$\mu\text{H}$	Measurement with VNA
$R_a$	1.7	$\Omega$	Measurement with VNA
$C_a$	9.12	pF	Calculated with eq. 2

**Table 2: Parameters of the equivalent antenna circuit of 760308101312**

The values for  $L_a$  and  $R_a$  have been measured at 13.56 MHz.

The equivalent antenna circuit parameters of the articles [760308101150](#), [760308103305](#), [760308102306](#) and [760308103307](#) are listed in the appendix A.2.

### 3.7 Determination of the complex impedance and the Q factor

The complex impedance  $Z_L$  of the NFC antenna of coil [760308101312](#) is calculated with equation (3) by integrating the parameters of the equivalent antenna circuit, which have been determined in the previous section and lead to the following complex impedance value.

$$Z_L = (1.87 + j 62.53) \Omega$$

This leads due to equation (4) to a  $Q_L$  of 33. Because the Q factor of the antenna is lower than 35, the damping resistors  $R_q$  can be omitted.

### 3.8 Calculation of the filter components and the complex impedance of the filter network

For the cut off frequency  $f_c$ , which can be calculated with equation (10), a value of 14.8 MHz has been chosen, which is higher than 14.4 MHz. An inductor value of 470 nH is chosen for  $L_0$ , which leads to a  $C_0$  of 247 pF. The values  $L_0$  and  $C_0$  have to be inserted into equation (11) to calculate the complex filter impedance. For  $R_0$ , the value of  $25 \Omega$  is inserted, which is the differential output impedance of a typical NFC IC in relation to the ground signal. These values lead to the following complex filter impedance:

$$Z_{EMC} = (165.82 - j 45.46) \Omega$$

### 3.9 Calculation of the matching component values

The matching reactances  $X_B$  and  $X_A$  can be directly calculated with equations (8) and (9). For  $R_S$ , the real part of the EMC network has to be integrated, which is  $165.82 \Omega$ . For the imaginary part of the source  $X_S$  the imaginary part of the EMC filter has to be integrated, which is  $-45.46 \Omega$ .

# Application Note

## Impedance Matching for Near Field Communication Applications



For  $R_L$  and  $X_L$ , the real and imaginary parts of the antenna network have to be integrated, which are  $1.87 \Omega$  and  $62.53 \Omega$ . The resulting matching reactances  $X_A$  and  $X_B$  can be calculated to the corresponding differential matching capacitors  $C_A$  and  $C_B$  with:

$$C_{A,B} = -\frac{2}{\omega \cdot X_{A,B}} \quad (14)$$

Table 3 gives an overview of the resulting reactance and capacitance values.

Parameter	Value	Unit	From equation
$X_{B1}$	-69.69	$\Omega$	(8)
$X_{A1}$	-519.81	$\Omega$	(9)
$X_{B2}$	-56.8	$\Omega$	(8)
$X_{A2}$	610.73	$\Omega$	(9)
$C_{B1}$	337	pF	(14)
$C_{A1}$	45	pF	(14)
$C_{B2}$	413	pF	(14)
$C_{A2}$	-38	pF	(14)

**Table 3: Resulting reactance and capacitor values**

The capacitor values for  $C_{A1}$  and  $C_{B1}$  are used for the matching, the values for  $C_{A2}$  and  $C_{B2}$  are neglected, because  $C_{A2}$  yields a negative value. Therefore the resulting matching capacitors for the differential output circuit are:

$$C_A = 45 \text{ pF}$$

$$C_B = 337 \text{ pF}$$

### 3.10 Calculation of the resulting reflection coefficient

To verify, if the calculated matching capacitor values  $C_A$  and  $C_B$  yield to a low reflection, the  $S_{11}$  parameter at the output of the NFC IC must be calculated. The smaller the absolute values is, the lower is the reflection and the better is the circuit matched to the  $50 \Omega$  output impedance of the NFC IC. The complex input port voltage reflection coefficient  $S_{11}$  can be calculated with formula (15).

$$S_{11} = \frac{Z_{in}' - 2R_D}{Z_{in}' + 2R_D} \quad (15)$$

where  $R_D = 25 \Omega$ , which is the single ended output impedance of the NFC IC. The parameter  $Z_{in}'$  depends on the input impedance  $Z_{in}$  (see equation (5)) and can be calculated with equation (16).

$$Z_{in}' = \frac{2 \cdot Z_{in}}{2 + j\omega C_0 Z_{in}} + 2j\omega L_0 \quad (16)$$

The absolute value of  $S_{11}$  can be calculated as:

$$|S_{11}| = \sqrt{\text{Re}(S_{11})^2 + \text{Im}(S_{11})^2} \quad (17)$$

In RF engineering,  $|S_{11}|$  is often given in a logarithmic scale, and can be calculated as:

$$|S_{11}|_{\text{dB}} = 20 \cdot \log(|S_{11}|) \quad (18)$$

The resulting values of equations (5), (15)-(18) are shown in table 4.

Parameter	Value	Unit	From equation
$Z_{in}$	$167.15 + j 45.69$	$\Omega$	(5)
$Z_{in}'$	$49.7 - j 0.276$	$\Omega$	(16)
$S_{11}$	$-0.00297 - j 0.00277$		(15)
$ S_{11} $	0.004		(17)
$ S_{11} _{\text{dB}}$	-48	dB	(18)

**Table 4: Calculated values for the reflection coefficient and the input impedance**

### 3.11 Simulation of the differential output circuit with Keysight ADS

An alternative and easier way to determine the matching capacitor values  $C_A$  and  $C_B$  is to simulate the differential output network shown in figure 5. The optimization tool, integrated in ADS, allows the determination of unknown parameters of the network. A simulation goal and the simulation parameters have to be defined. To determine the matching capacitor values by simulation, the following steps have to be performed:

1. Create the schematic of the differential output network shown in figure 5 with the filter component values calculated in section 3.8 and the equivalent antenna network values determined in section 3.6. An input port with a  $50 \Omega$  impedance has been used.
2. Definition of the simulation type and the simulation variables
3. Definition of the optimization goal and the optimization iterations
4. Execution of the optimization and definition of the output plot type

### 3.12 Schematic of the differential output network

Figure 9 shows the ADS schematic of the differential output network (see figure 5) with input port 1 and source impedance of  $50 \Omega$ .

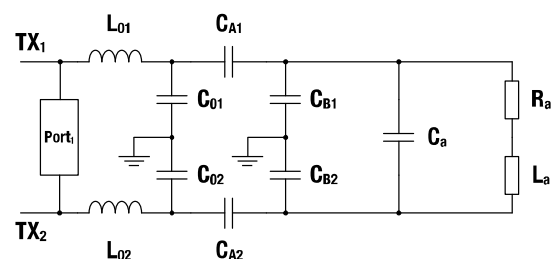

**Figure 9: ADS schematic of the differential output network**

# Application Note

## Impedance Matching for Near Field Communication Applications



### 3.13 Definition of the simulation type and the simulation variables

The chosen simulation type is the Large-Signal S-Parameter Simulation, which is based on a harmonic balance algorithm. This simulation type computes S-parameters for linear and nonlinear RF circuits. The simulation variables are the matching capacitors  $C_A$  and  $C_B$ , which have to be determined by the algorithm. The range of 1-1000 pF has been chosen. For the two capacitors, start values have to be defined.

### 3.14 Definition of the optimization goal and iterations

As an optimization goal, it has been defined that  $|S_{11}|$  should be less than 0.0001 in a frequency band between 13.559 MHz and 13.561 MHz. 1000 optimization iterations have been chosen.

### 3.15 Execution of the optimization and definition of the output plot type

The simulated matching capacitance values result to  $C_A = 45$  pF and  $C_B = 337$  pF, which are the same values calculated in section 3.9.

The simulated reflection coefficient  $|S_{11}|$  has been visualized in a Smith chart (see figure 10) and has been plotted (see figure 11) in the frequency range from 12 MHz to 15 MHz.

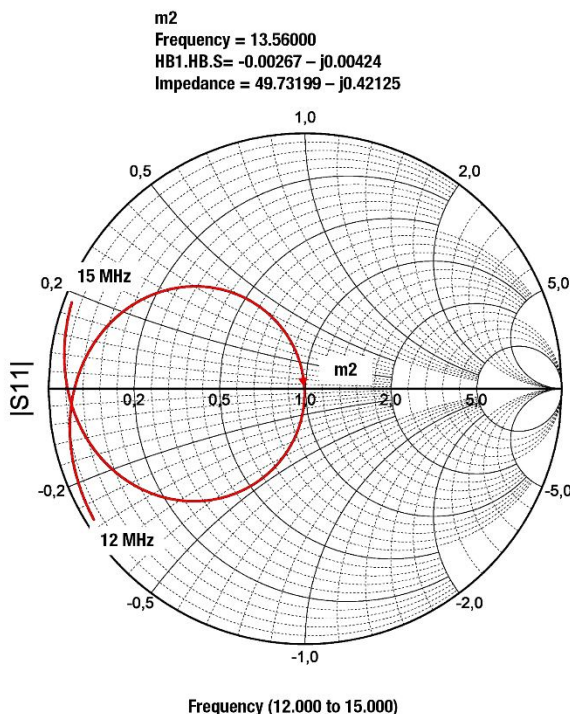

Figure 10: Simulated Smith chart of  $|S_{11}|$  over frequency

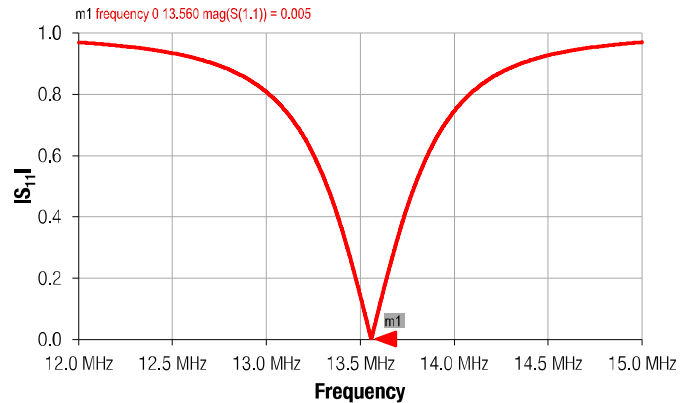

Figure 11: Simulation of  $|S_{11}|$  over frequency

For the frequency of 13.56 MHz, the simulated values of the input impedance  $Z_{in}'$  and the reflection coefficient  $S_{11}$  are shown in table 5.

Parameter	Simulated value
$Z_{in}'$	$(49.73 - j 0.42) \Omega$
$S_{11}$	$-0.00267 - j 0.00424$
$ S_{11} $	0.005
$ S_{11} _{dB}$	-46 dB

Table 5: Simulated values for the reflection coefficient and the input impedance at 13.56 MHz

The simulated values of  $S_{11}$ ,  $|S_{11}|$  and  $|S_{11}|_{dB}$  are quite similar to the calculated values, shown in table 4. Because of the precise values of  $C_A = 45$  pF and  $C_B = 337$  pF, the reflexion parameters are very low. In real circuits, these precise capacitor values can not be reached, which results into higher reflexion coefficients.

### 3.16 Verification of the matching by measurement and matching adaptation measures

The calculations and simulations are done with ideal components, without considering parasitic and tolerance influences. But in reality the capacitors and the inductors have tolerances and parasitic inductances and capacitances. In addition, the components of the equivalent circuit of the antenna are measured and therefore not very precise, thus have tolerances, too. Apart from geometrical and chemical variations induced by the manufacturing process, there are also uncertain parameters about the surrounding or additional ferrite foils for shielding. Any metal in close proximity to the antenna may change the impedance of the antenna and thus also the overall input impedance. How much these variations influence the input impedance mainly depends on the desired value of the input impedance and the quality factor. In general, lower quality factors and higher values of the input impedance are less sensitive to a variation of component values. [5]

# Application Note

## Impedance Matching for Near Field Communication Applications



In view of these variations, an additional iteration of the matching is necessary. In the first step, the differential output circuit, which is shown in figure 5, with the calculated matching capacitor values has to be manufactured. The second step is to measure the input impedance with a network analyzer. The matching capacitors  $C_A$  and  $C_B$  have to be adjusted, so that the input impedance reaches the value of  $50 \Omega$ .

### 3.17 Differential NFC output circuit board and reflection coefficient measurement

To design the PCB of the differential output circuit, the program Altium Designer V.18.1.19 has been used. The Altium schematic of the differential NFC output circuit is shown in figure 12.

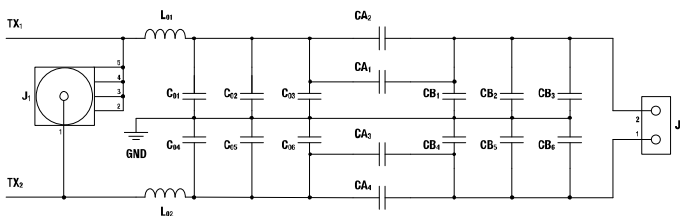

Figure 12: Altium schematic of the differential NFC output circuit

For the filter inductance  $L_0 = 470 \text{ nH}$  (see  $L_{01}$  and  $L_{02}$  at figure 12) the WE part [744762247GA](#) has been used. The filter capacitance  $C_0 = 247 \text{ pF}$  comprises of two  $100 \text{ pF}$  parts of the WE Caps Series with part number [85012006038](#) (see  $C_{01}$ ,  $C_{02}$ ,  $C_{04}$  and  $C_{05}$  at figure 12) and the  $47 \text{ pF}$  capacitor with part number [885012006055](#) (see  $C_{03}$  and  $C_{06}$  at figure 12). The same capacitor has been used for  $C_A$  (see  $C_{A2}$  and  $C_{A4}$  at figure 12). The capacitance  $C_B = 337 \text{ pF}$  comprises of a  $330 \text{ pF}$  capacitor with WE part number [885012006041](#) (see  $C_{B1}$  and  $C_{B4}$  at figure 12) and a  $6.8 \text{ pF}$  capacitor with WE part number [885012006050](#) (see  $C_{B2}$  and  $C_{B5}$  at figure 12). At the input port J1 of the network, the following impedance vs. frequency dependency has been measured with an Agilent Technologies E5061 network analyzer in the frequency band between  $12 \text{ MHz}$  and  $15 \text{ MHz}$ .

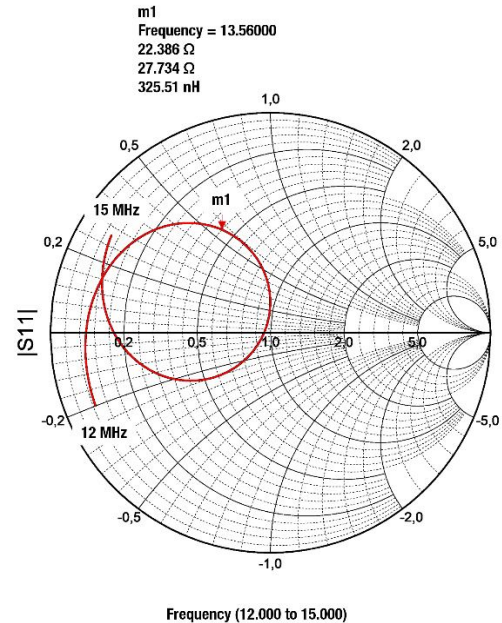

Figure 13: Measurement of the reflection coefficient in dependence of the frequency shown in a Smith chart

A marker at the frequency of  $13.56 \text{ MHz}$  shows an input impedance of  $22.4 \Omega + j 27.7 \Omega$ .

Due to equations (15) to (18) the calculated logarithmic absolute value of the input port voltage reflection coefficient  $|S_{11}|_{\text{dB}}$  yields to  $-5.94 \text{ dB}$ .

The value has been verified by measuring the  $|S_{11}|_{\text{dB}}$  in dependence of the frequency. The measurement result is shown in figure 14.

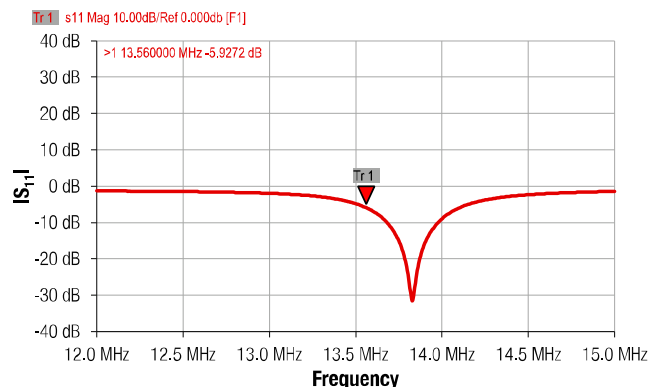

Figure 14: Measurement of the logarithmic absolute value of the input port voltage reflection coefficient in dependence of the frequency

The marker at the frequency of  $13.56 \text{ MHz}$  yields  $|S_{11}|_{\text{dB}} = -5.92 \text{ dB}$ . To improve the matching, at least one of the matching capacitors has to be adapted.

# Application Note

## Impedance Matching for Near Field Communication Applications



### 3.18 Determination of the necessary adaption of the matching capacitance values by simulation

To determine which of the matching capacitors has to be adapted, the influence of both capacitors  $C_A$  and  $C_B$  on  $|S_{11}|$  and  $Z_{in}$  is investigated by an ADS parameter sweep simulation.

Figure 15 shows the Smith chart of  $|S_{11}|$  in dependence of  $C_A$  and  $C_B$  at the frequency of 13.56 MHz.

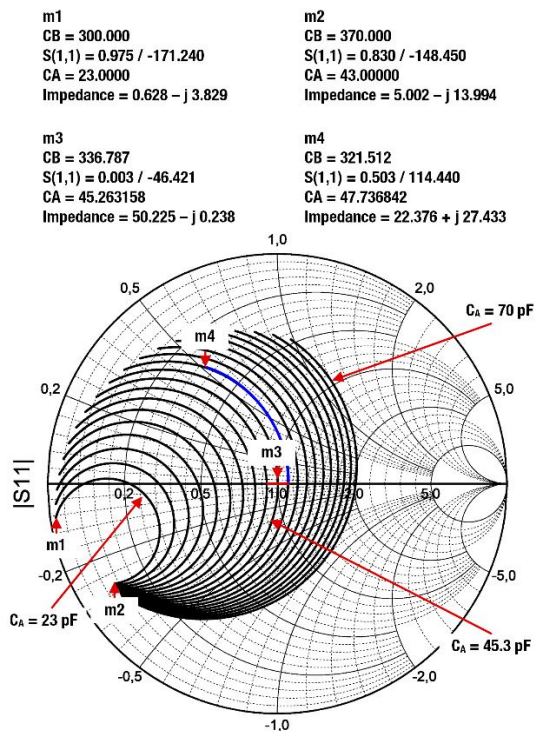

Figure 15: Simulation of  $|S_{11}|$  in dependence of  $C_A$  and  $C_B$  shown in a Smith chart

The parameter sweep of  $C_B$  goes from 300 pF to 370 pF in 0.7 pF steps, which is a 10 % variation of the nominal value of 337 pF and the parameter sweep of  $C_A$  goes from 23 pF (the left curve) to 70 pF (right curve) in 2.5 pF steps, which is a variation of 50 % of the nominal value of 47 pF. In figure 15, the marker 'm3' shows the desired 50  $\Omega$  matching point, which occurs at the curve for  $C_A = 45.3$  pF. The red line indicates the tolerance range of the values of capacitance  $C_A$  and the blue line indicates the difference of the capacitance  $C_B$ , which leads from the measured impedance (indicated by marker 'm4') to a matching value of about -26.6 dB. At the marker 'm4', the value for  $C_B$  is 322 pF, which is about 15 pF smaller than the value of 337 pF, which is reached at the real axis of the Smith chart. This implies, that a capacitor of 15 pF has to be added to  $C_B$ , to reach the desired matching point. At the matching test board (see schematic at figure 12) for  $C_{B3}$  and  $C_{B6}$ , two 15 pF capacitors (one at  $C_{B3}$  and one for  $C_{B6}$ ) have been soldered in (WE number [885012006052](#)). After the integration of the capacitors, the measurement,

which is shown in the figures 13 and 14 has been repeated. The results are shown in the figures 16 and 17. The measurement shows, that the parameter  $|S_{11}|_{dB}$  changed from -5.92 dB to the value of -26.1 dB at a frequency of 13.56 MHz due to the optimization of  $C_B$ .

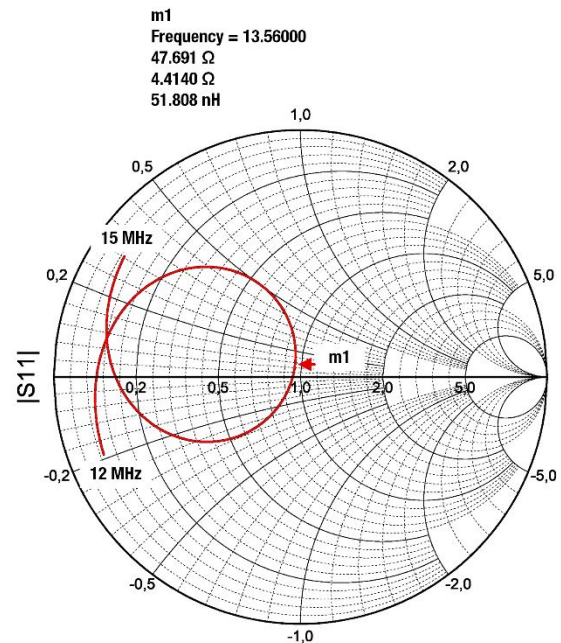

Figure 16: Measurement of the reflection coefficient with frequency shown in a Smith chart after the matching capacitor  $C_B$  has been adapted

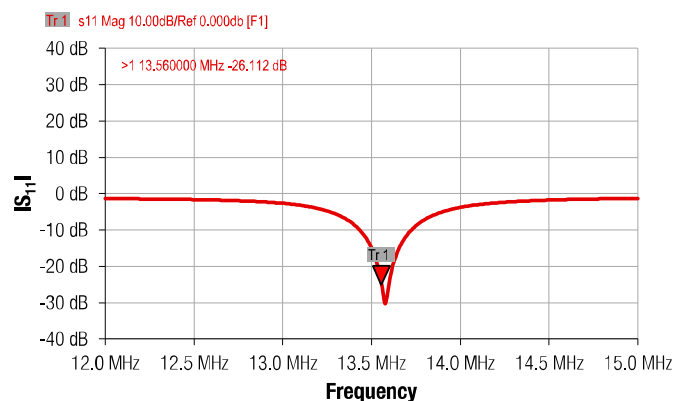

Figure 17: Measurement of the logarithmic absolute value of the input port voltage reflection coefficient with frequency

# Application Note

## Impedance Matching for Near Field Communication Applications



### 3.19 Determination of the necessary adaption of the matching capacitance values by calculation

The change of  $C_B$  and  $C_A$  to reach the necessary  $50 \Omega$  matching impedance can also be done mathematically. To do so, the following calculation steps have to be performed:

1. Integrate the measured value for  $Z_{in}'$  (e. g.  $22.4 \Omega + j 27.7 \Omega$ ) into equation (16) and solve the equation for  $Z_{in}$ :

$$Z_{in} = \frac{4j\omega L_0 - 2Z_{in}'}{j\omega C_0 Z_{in}' - 2 + 2\omega^2 C_0 L_0} = R_S - jX_S \quad (19)$$

$$= (87.18 - j 70.95) \Omega$$

2. Integrate the imaginary part ( $X_S = 70.95 \Omega$ ) and real part ( $R_S = 87.18 \Omega$ ) of  $Z_{in}$  calculated with equation (19) into the equations (8) and (9) and calculate  $X_{A1,2}$  and  $X_{B1,2}$ .

$$X_{B1} = -73 \Omega$$

$$X_{B2} = -54.74 \Omega$$

$$X_{A1} = -489 \Omega$$

$$X_{A2} = 347.27 \Omega$$

3. Use equation (14) to calculate the corresponding  $C_{A1,2}$  and  $C_{B1,2}$  values:

$$C_{B1} = 322 \text{ pF}$$

$$C_{B2} = 429 \text{ pF}$$

$$C_{A1} = 48 \text{ pF}$$

$$C_{A2} = -67 \text{ pF}$$

Because  $C_{A2}$  yields a negative value, the capacitances  $C_{B2}$  and  $C_{A2}$  can be neglected.

4. Determine the difference of the resulting  $C_A$  and  $C_B$  values to their calculated or simulated values. The calculated values (see section 3.9) for  $C_A$  and  $C_B$  are:

$$C_{A,calc} = 45 \text{ pF}$$

$$C_{B,calc} = 337 \text{ pF}$$

The values for  $C_A$  and  $C_B$  determined via measurement in the previous section are:

$$C_{A,meas} = 48 \text{ pF}$$

$$C_{B,meas} = 322 \text{ pF}$$

The differences of the capacitances  $\Delta C_A$  and  $\Delta C_B$  are:

$$\Delta C_A = C_{A,calc} - C_{A,meas} = 45 \text{ pF} - 48 \text{ pF} = -3 \text{ pF}$$

$$\Delta C_B = C_{B,calc} - C_{B,meas} = 337 \text{ pF} - 322 \text{ pF} = 15 \text{ pF}$$

With these results, the capacitance  $C_A$  has to be decreased by 3 pF and the capacitance  $C_B$  has to be increased by 15 pF to reach a perfect impedance match. Because the difference value of  $\Delta C_A = 3 \text{ pF}$  is about in the range of the tolerance of  $C_A$ , this value has not been changed. In this section it has been shown by simulation and measurement, that the capacitance  $C_B$  has to be increased by 15 pF to reach a matching value

of about -26 dB. It has to be considered, that the output circuit is differential, which means that the 15 pF has to be soldered twice into the matching circuit, at the places  $C_{B3}$  and  $C_{B6}$  (see figure 12).

### 4 Summary

This application note describes how a WE NFC antenna can be matched to a NFC IC. The determination of the matching capacitor values has been described by calculation and simulation. The measurement and necessary adaption of the input impedance to the source impedance has been shown. The basics of the complex impedance matching theory have been stated and typical L-matching topologies are shown. The calculation of the matching reactances and the determination of the Q factor have been performed. The different parts of differential output network have been analyzed and the dimensioning of the single components of the filter and the equivalent antenna components has been performed. Finally, the differential output network has been manufactured and the matching capacitors have been adapted to improve the matching.

# Application Note

## Impedance Matching for Near Field Communication Applications



### A Appendix

#### A.1 Bill of Materials

Index	Description	Size	Specifications $f_{WPT} = 125 \text{ kHz}; f_{NFC} = 13.56 \text{ MHz}$	Partnumber
	WPT/NFC Combo Transmitter Coil	Ø65 x 3.5 mm	$L_{1,WPT} = 6.3 \mu\text{H}, L_{2,NFC} = 1.2 \mu\text{H},$ $Q_{1,WPT} = 100, Q_{2,NFC} = 80$	<a href="#">760308101150</a>
	WPT/NFC Combo Transmitter Coil	Ø54 x 4 mm	$L_{1,WPT} = 24 \mu\text{H}, L_{2,NFC} = 0.7 \mu\text{H},$ $Q_{1,WPT} = 125, Q_{2,NFC} = 30$	<a href="#">760308101312</a>
	WPT/NFC Combo Receiver Coil	45 x 44 x 0.72 mm	$L_{1,WPT} = 8.8 \mu\text{H}, L_{2,NFC} = 1.6 \mu\text{H}$ $Q_{1,WPT} = 30, Q_{2,NFC} = 47$	<a href="#">760308103305</a>
	WPT/NFC Combo Receiver Coil	44 x 44 x 1 mm	$L_{1,WPT} = 8 \mu\text{H}, L_{2,NFC} = 1.4 \mu\text{H},$ $Q_{1,WPT} = 19, Q_{2,NFC} = 47$	<a href="#">760308102306</a>
	WPT/NFC Combo Receiver Coil	40 x 27 x 1 mm	$L_{1,WPT} = 7.8 \mu\text{H}, L_{2,NFC} = 1.6 \mu\text{H},$ $Q_{1,WPT} = 19, Q_{2,NFC} = 47$	<a href="#">760308103307</a>
<b>L<sub>0</sub></b>	WE-KI SMT Wire Wound Ceramic Inductor	1008	$L = 470 \text{ nH}, Q = 45$	<a href="#">744762247GA</a>
<b>C<sub>0</sub></b>	WCAP-CSGP Multilayer Ceramic Capacitor	0603	$C = 100 \text{ pF}$	<a href="#">885012006038</a>
<b>C<sub>0</sub></b>	WCAP-CSGP Multilayer Ceramic Capacitor	0603	$C = 47 \text{ pF}$	<a href="#">885012006055</a>
<b>C<sub>A</sub></b>	WCAP-CSGP Multilayer Ceramic Capacitor	0603	$C_{A1} = 47 \text{ pF}$	<a href="#">885012006055</a>
<b>C<sub>B1</sub></b>	WCAP-CSGP Multilayer Ceramic Capacitor	0603	$C = 330 \text{ pF}$	<a href="#">885012006052</a>
<b>C<sub>B2</sub></b>	WCAP-CSGP Multilayer Ceramic Capacitor	0603	$C = 6.8 \text{ pF}$	<a href="#">885012006041</a>
<b>C<sub>B3</sub></b>	WCAP-CSGP Multilayer Ceramic Capacitor	0603	$C = 15 \text{ pF}$	<a href="#">885012006050</a>
<b>J<sub>1</sub></b>	WR-SMA SMA PCB THT Jack Straight		SMA connector	<a href="#">60312002114503</a>
<b>J<sub>2</sub></b>	WR-TBL Terminal Block		2.54 mm horizontal entry clamp	<a href="#">691210910002</a>

#### A.2 Equivalent antenna circuit parameters

Artikelnummer	$f_s$ (MHz)	$R_a$ ( $\Omega$ )	$L_a$ ( $\mu\text{H}$ )	$C_a$ (pF)
<b>760308101150</b>	48	1.19	1.16	9.48
<b>760308103305</b>	50	4	1.58	6.4
<b>760308102306</b>	50	2.4	1.6	6.3
<b>760308103307</b>	54	3.7	1.7	5.1

# Application Note

## Impedance Matching for Near Field Communication Applications



### A.3 Literature

- [1] C. Bowick, RF Circuit Design, 2nd Revised edition, Newnes, 2007, Pg 67.
- [2] K. Cartwright, Non-Calculus Derivation of the Maximum Power Transfer Theorem, *Technology Interface*, 8 (2), 2008.
- [3] M. Roland, Automatic Impedance Matching for 13.56 MHz NFC Antennas, 6th International Symposium on Communication Systems, Networks and Digital Signal Processing, 2008.
- [4] Würth Elektronik eiSos, ANP057a, WE-MCA Multilayer Chip Antenna Placement & Matching, Application Note, 2018.
- [5] T. Baier: Automated Impedance Adjustment of 13.56 MHz NFC Reader Antennas, Master Thesis, 2014.
- [6] A. Schober, M. Ciacci, and M. Gebhart, An NFC Air Interface coupling model for Contactless System Performance estimation, International Conference on Telecommunications (ConTEL), June 2013.
- [7] Rohde und Schwarz, Near Field Communication (NFC) Technology and Measurements, White Paper, 2011.
- [8] NXP Corporation, AN11564, Antenna Design and Matching Guide, Application Note, 2016.

# Application Note

## Impedance Matching for Near Field Communication Applications



### IMPORTANT NOTICE

The Application Note is based on our knowledge and experience of typical requirements concerning these areas. It serves as general guidance and should not be construed as a commitment for the suitability for customer applications by Würth Elektronik eiSos GmbH & Co. KG. The information in the Application Note is subject to change without notice. This document and parts thereof must not be reproduced or copied without written permission, and contents thereof must not be imparted to a third party nor be used for any unauthorized purpose.

Würth Elektronik eiSos GmbH & Co. KG and its subsidiaries and affiliates (WE) are not liable for application assistance of any kind. Customers may use WE's assistance and product recommendations for their applications and design. The responsibility for the applicability and use of WE Products in a particular customer design is always solely within the authority of the customer. Due to this fact it is up to the customer to evaluate and investigate, where appropriate, and decide whether the device with the specific product characteristics described in the product specification is valid and suitable for the respective customer application or not.

The technical specifications are stated in the current data sheet of the products. Therefore the customers shall use the data sheets and are cautioned to verify that data sheets are current. The current data sheets can be downloaded at [www.we-online.com](http://www.we-online.com). Customers shall strictly observe any product-specific notes, cautions and warnings. WE reserves the right to make corrections, modifications, enhancements, improvements, and other changes to its products and services.

WE DOES NOT WARRANT OR REPRESENT THAT ANY LICENSE, EITHER EXPRESS OR IMPLIED, IS GRANTED UNDER ANY PATENT RIGHT,

COPYRIGHT, MASK WORK RIGHT, OR OTHER INTELLECTUAL PROPERTY RIGHT RELATING TO ANY COMBINATION, MACHINE, OR PROCESS IN WHICH WE PRODUCTS OR SERVICES ARE USED. INFORMATION PUBLISHED BY WE REGARDING THIRD-PARTY PRODUCTS OR SERVICES DOES NOT CONSTITUTE A LICENSE FROM WE TO USE SUCH PRODUCTS OR SERVICES OR A WARRANTY OR ENDORSEMENT THEREOF.

WE products are not authorized for use in safety-critical applications, or where a failure of the product is reasonably expected to cause severe personal injury or death. Moreover, WE products are neither designed nor intended for use in areas such as military, aerospace, aviation, nuclear control, submarine, transportation (automotive control, train control, ship control), transportation signal, disaster prevention, medical, public information network etc. Customers shall inform WE about the intent of such usage before design-in stage. In certain customer applications requiring a very high level of safety and in which the malfunction or failure of an electronic component could endanger human life or health, customers must ensure that they have all necessary expertise in the safety and regulatory ramifications of their applications. Customers acknowledge and agree that they are solely responsible for all legal, regulatory and safety-related requirements concerning their products and any use of WE products in such safety-critical applications, notwithstanding any applications-related information or support that may be provided by WE.

CUSTOMERS SHALL INDEMNIFY WE AGAINST ANY DAMAGES ARISING OUT OF THE USE OF WE PRODUCTS IN SUCH SAFETY-CRITICAL APPLICATIONS.

### USEFUL LINKS



Application Notes

[www.we-online.com/app-notes](http://www.we-online.com/app-notes)



**REDEXPERT** Design Plattform

[www.we-online.com/redexpert](http://www.we-online.com/redexpert)



Toolbox

[www.we-online.com/toolbox](http://www.we-online.com/toolbox)



Product Catalog

[www.we-online.com/products](http://www.we-online.com/products)

### CONTACT INFORMATION

[appnotes@we-online.com](mailto:appnotes@we-online.com)

Tel. +49 7942 945 - 0



Würth Elektronik eiSos GmbH & Co. KG  
Max-Eyth-Str. 1 · 74638 Waldenburg · Germany

[www.we-online.com](http://www.we-online.com)

