Name		
Matrikel-Nr.		

Experiment 3: Rectifiers

Objectives of the experiment

Getting to know the following components

- Half-wave rectifier, bridge rectifier
- Ripple voltage
- Fixed voltage regulator
- Three-phase AC(), three-phase bridge rectifier

Applying

- Voltage analysis in the time domain using a simulation program

Practical Example Rectifier (Diode)

You have an electric vehicle and want to charge the battery from an AC() grid voltage. An on-board charger (OBC) of an electric vehicle converts AC() grid voltage into DC() voltage to charge the high-voltage battery.

Operating Principle:

AC() Input

- The grid provides a sinusoidal AC() voltage that alternates between positive and negative values.

Rectification (Full-Bridge)

- A full-bridge rectifier uses four diodes. During each half-cycle, two diodes conduct, ensuring that current always flows in the same direction through the load.

Pulsating DC() Output

- The output voltage is always positive but contains significant ripple at twice the grid frequency (100 Hz).

Smoothing

- A capacitor connected in parallel to the load reduces voltage ripple by storing and releasing energy.

Active Rectification (PFC)

- In real EV chargers, active rectifiers improve efficiency and power factor by shaping the input current to follow the voltage waveform.

Voltage Divider and Bridge Circuit

In earlier experiments, various circuits were built. Specifically, the voltage divider (left), the simple diode circuit with series resistor (middle), and a capacitor circuit with series resistor (right) were already described, s. figure 1. In principle, the last two circuits and many more can also be understood as voltage dividers. For this reason, the voltage divider is a central circuit in electrical engineering and is often called a **half-bridge**.

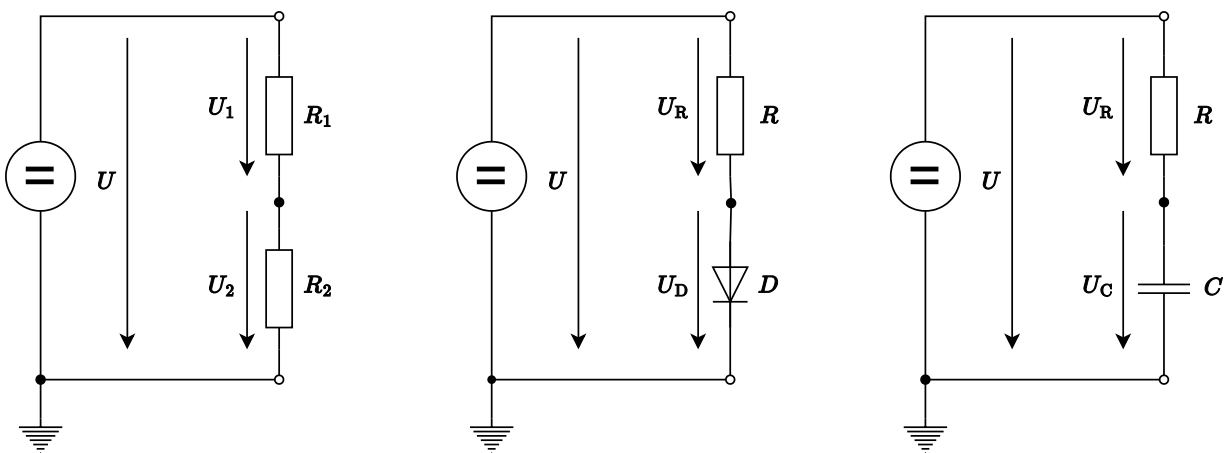

Fig. 1: Various circuits

Another central circuit can be created by placing two half-bridges in series and connecting both through a bridge branch. In this way, one obtains the **full bridge** or H-bridge (s. figure 2).

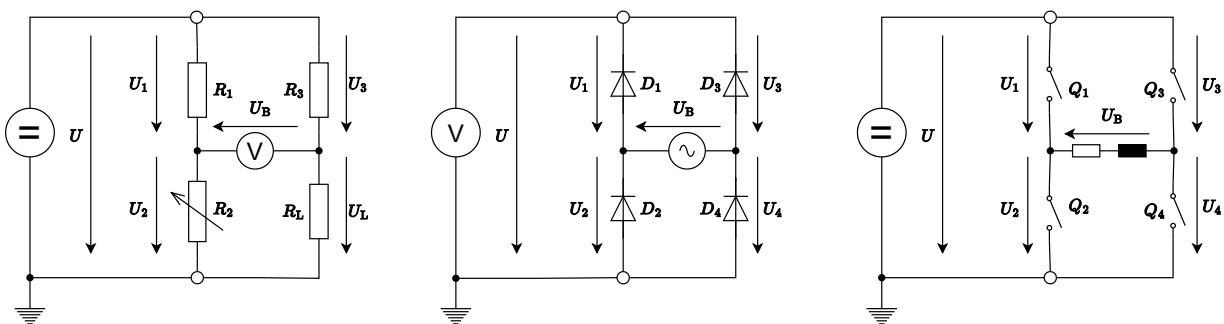

Fig. 2: H-shape bridges

From the H-bridge, many different circuits can be derived. figure 2 left shows the Wheatstone measuring bridge, in which the resistor R_L can be determined using a potentiometer R_2 and a voltmeter. In the right image, the switching full bridge is shown, which can, for example, drive a motor. The middle image shows the bridge rectifier, which will be described in more detail later.

Always pay attention in full-bridge circuits to where the input and output voltages are located.

Both half-bridge and full-bridge are used for rectification in this experiment.

The Half-Wave Rectifier

In a half-wave rectifier, only one half-wave of the $\underline{u}_{AC}(t)$ voltage is rectified; the other half-wave is not used. Such a rectifier consists only of a single diode. During the half-period in which the diode is operated in forward direction, a voltage is built up at the output (s. figure 3). In the second half-period, the diode is operated in reverse direction. If the diode is operated in reverse direction, no current can flow because the diode does not become conductive. As a result, no current can flow through the resistor. Thus, the entire negative voltage of the second half-wave lies across the diode and not across the resistor.

Disadvantages of half-wave rectification are the comparatively large ripple on the $\underline{u}_{DC}(t)$ side and the poor efficiency. In addition, the upstream transformer becomes magnetized because it is only traversed by current in one direction.

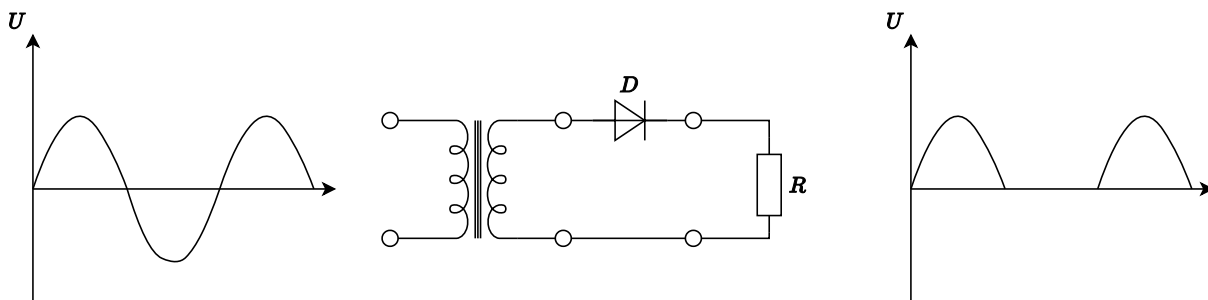

Fig. 3: Principle of a half-wave rectifier

Measurements on the Half-Wave Rectifier with the Oscilloscope

Build the half-wave rectifier circuit shown in figure 4 with the diode and the load resistor. Take the transformer output voltage u_{Sec} from the variable low-voltage terminals (**L1** and **N** at your table). The voltages u_{Sec} and u_R are to be measured with the oscilloscope. Draw the connection between the circuit and the oscilloscope in figure 4.

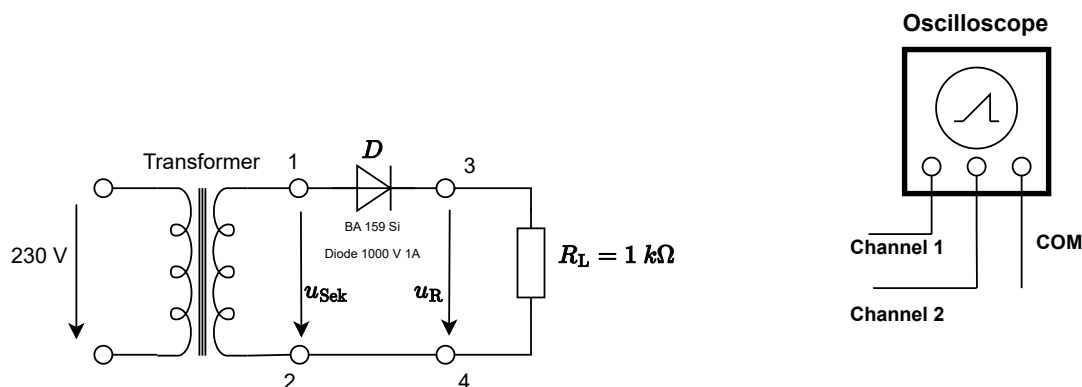
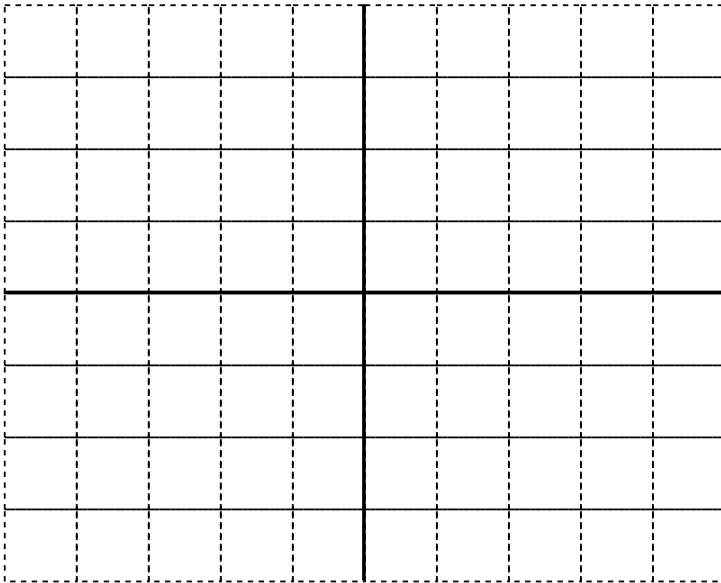

Fig. 4: Half-wave rectifier circuit

Sketch the oscilloscope display with the voltages u_{Sec} and u_R in the screen image figure 5. Also document the settings of the channels used, the time base and the $\underline{GND}(\dots)$ line on the left side of the screen image.



Channel 1: $\frac{V}{DIV} =$

Channel 2: $\frac{V}{DIV} =$

Time basis: $\frac{T}{DIV} =$

Fig. 5

Switch now a capacitor (electrolytic capacitor) with $100 \mu F$ in parallel to the resistor R_L and sketch the voltage curve of u_{Sec} and u_R again.

Warning: When using an electrolytic capacitor, observe the correct polarity!

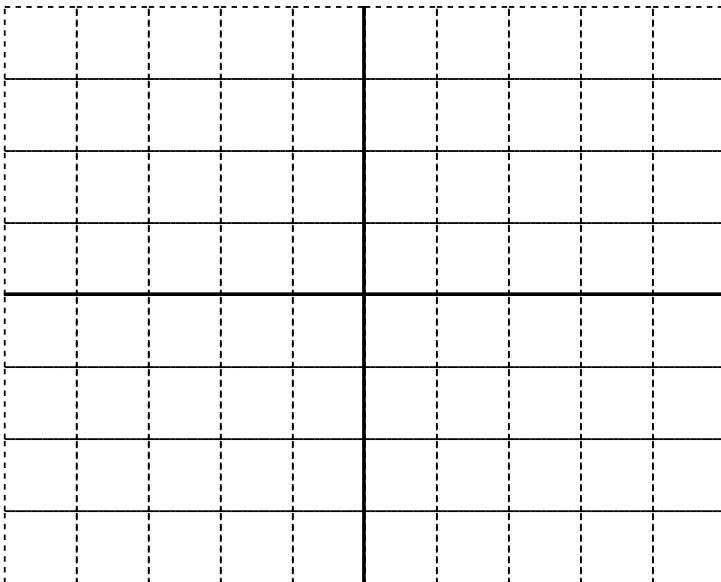

Channel 1: $\frac{V}{DIV} =$

Channel 2: $\frac{V}{DIV} =$

Time basis: $\frac{T}{DIV} =$

Fig. 6

Measure the following values with the help of the oscilloscope and enter the results in table 1 ($C = 100 \mu F$):

- Secondary-side voltage of the transformer \hat{u}_{Sec}
- Frequency of the secondary transformer voltage f_{Sec}
- Peak-to-peak ripple voltage $u_{PP-ripple}$
- Ripple frequency f_{Ripple}
- Average value of the rectified voltage $|\bar{u}_R|$

- Peak value of the rectified voltage $u_{R, \max}$

C	\hat{u}_{Sec}	f_{Sec}	$u_{\text{Ripple,PP}} *$	f_{Ripple}	$ \bar{u}_{\text{R}} $	$u_{\text{R-max}}$
100 μF						

*) PP = Peak-Peak-value = Peak-Bottom-value

Tab. 1: Rectifier

Consider a measure with which the ripple voltage can be reduced. Sketch the circuit with your solution in figure 7 and measure the voltages u_{Sec} and u_{R} . Enter these **with another color** into the screen image shown above figure 6.

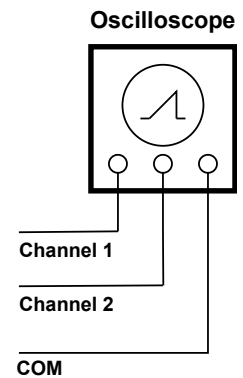

Fig. 7

Carry out the corresponding measurements – as above – again on the half-wave rectifier. These were the secondary-side voltage of the transformer \hat{u}_{Sec} , the frequency of the secondary transformer voltage f_{Sec} , the peak-to-peak value of the ripple voltage $u_{\text{PP-ripple}}$, the ripple frequency f_{Ripple} , the average value of the rectified voltage $|\bar{u}_{\text{R}}|$ and the peak value of the rectified voltage $u_{\text{R, max}}$. Enter the results in the second free line of table 1.

Bridge Rectifier

In figure 8 the circuit of a bridge rectifier is shown. Enter the current arrows correctly. Draw the connection between the oscilloscope and the circuit in order to measure the output voltage u_{R} at the rectifier. Explain why one cannot measure the secondary voltage of the transformer and the output voltage of the bridge rectifier at the same time.

.....

.....

.....

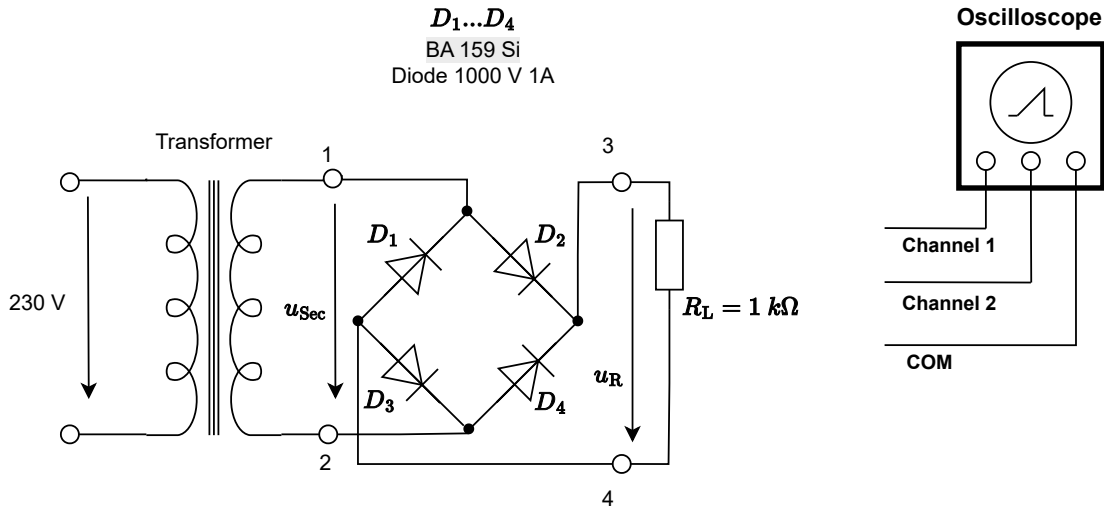
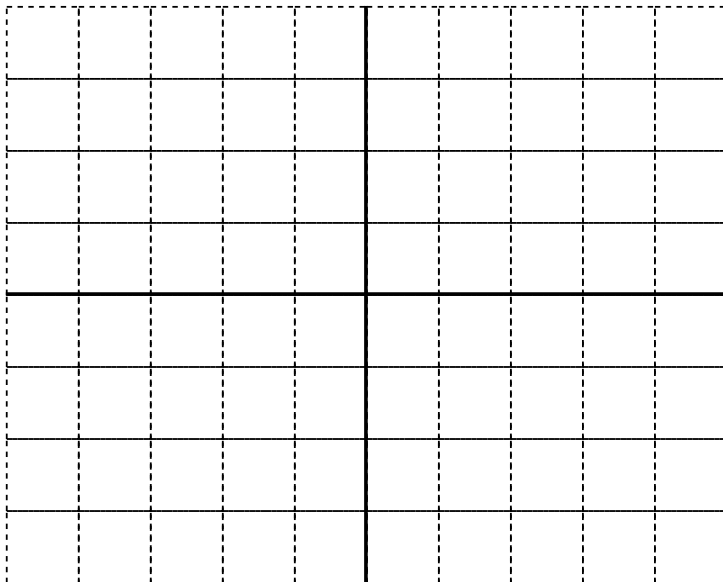

Fig. 8

Build the circuit on the breadboard and connect the oscilloscope. Then sketch the voltage curve before and after the bridge rectifier, i.e. the voltages u_{rmSec} and u_R . However, note that you connect the ground of the oscilloscope before or after the bridge rectifier for the respective measurement. Also give the oscilloscope settings used.



Channel 1: $\frac{V}{DIV} =$

Channel 2: $\frac{V}{DIV} =$

Time basis: $\frac{T}{DIV} =$

Fig. 9

Now connect a capacitor (electrolytic capacitor) with $100 \mu F$ in parallel to the resistor R_L and sketch the voltage curve of u_{rmSec} and u_R again in figure 9 with a different color.

Warning: When using an electrolytic capacitor (Elko) the correct polarity must be observed!

Measure the following values with the help of the oscilloscope in the circuit and enter the results into table 2 ($100 \mu F$):

C	\hat{u}_{Sec}	f_{Sec}	$u_{Ripple,PP}^*)$	f_{Ripple}	$ \bar{u}_R $	u_{R-max}
$100 \mu F$						

*) PP = Peak-Peak-value = Peak-Bottom-value

Tab. 2: Bridge-Rectifier measured values

Consider a measure by which the ripple voltage can be reduced. Draw the circuit with your found solution into figure 10 and measure the voltage curves u_{rmSec} and u_R . Enter these into the screen image figure 9 with a third color.

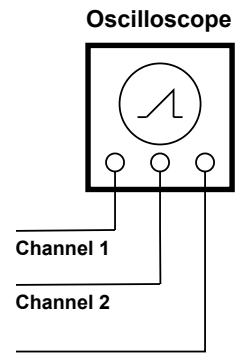

Fig. 10

Carry out the corresponding measurements – as above – again on the bridge rectifier. These were the secondary-side voltage of the transformer \hat{u}_{Sec} , the frequency of the secondary transformer voltage f_{Sec} , the peak-to-peak value of the ripple voltage $u_{PP-ripple}$, the ripple frequency f_{Ripple} , the average value of the rectified voltage $|\bar{u}_R|$ and the peak value of the rectified voltage $u_{R,max}$. Enter the results in the second free line of table 2.

Fixed Voltage Regulator

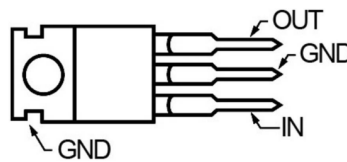

Fig. 11

Through the use of a fixed voltage regulator, a regulated DC(.) voltage of 5 V shall now be generated. Draw the corresponding circuit with transformer, bridge rectifier, capacitor, fixed voltage regulator 7805 and resistor into figure 12. Complete the existing circuit with the 7805 voltage regulator and simultaneously record the voltage at the input and output of the fixed voltage regulator with the oscilloscope into the screen image shown below.

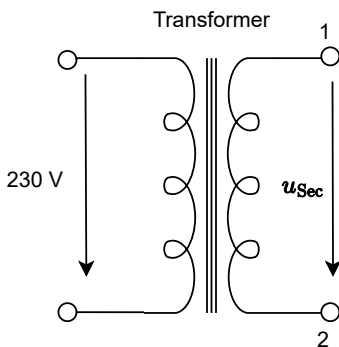
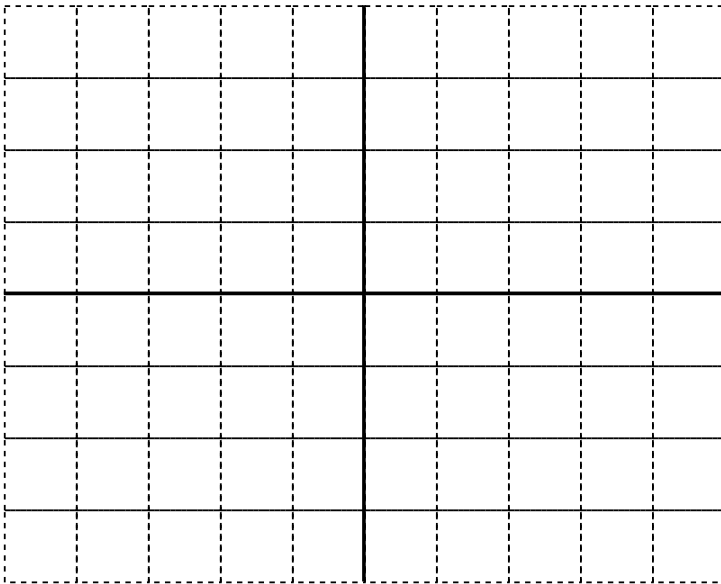

Fig. 12



Channel 1: $\frac{V}{DIV} =$

Channel 2: $\frac{V}{DIV} =$

Time basis: $\frac{T}{DIV} =$

Fig. 13

Determine the required values from table 3 using the oscilloscope at the output of the fixed voltage regulator:

$u_{\text{Ripple,PP}} *$	f_{Ripple}	$ \bar{u}_{\text{Out}} $

*) PP = Peak-Peak-value = Peak-Bottom-value

Tab. 3: Fixed voltage regulator value table

Comparison of the circuits from table 1 and table 2:

Now compare the measured values of the half-wave rectifier circuit with the values of the bridge circuit and document your findings in a few short sentences (advantages, disadvantages).

.....

.....

.....

.....

.....

Comparison of the circuits from table 2 and table 3:

What additional advantage does the fixed voltage regulator provide with regard to the peak-to-peak value of the ripple voltage and the ripple frequency?

.....

.....

.....

.....

Three-phase AC

In a DC network or an AC network with only two live conductors, only a single voltage is available at the end of the line. In contrast, in a three-phase AC network (three-phase current) with the external conductors L1, L2, L3 and the neutral conductor N, the possibility arises to connect to two different voltage levels. The three external conductors can be used individually or together with the neutral conductor to supply electrical loads. This enables the economic supply of consumers with greatly differing power consumption on the same network. The generator circuit diagram is shown in figure 14.

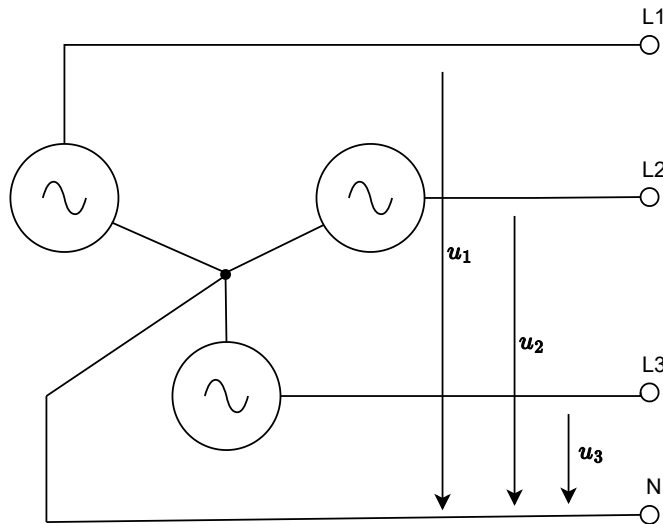
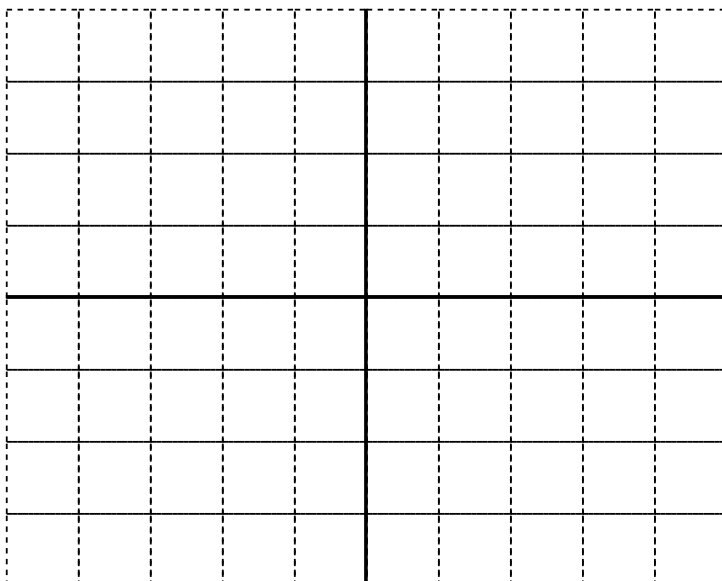

Fig. 14: Generator circuit diagram

At the control panel of your laboratory workstation there are sockets. The designations of the sockets are: L1, L2, L3 and N. Connect these sockets to your breadboard. **Warning: There is a risk of short circuit!**

Sketch the voltages U_1 , U_2 and U_3 using the oscilloscope. Enter all three line-to-neutral voltages into a single screen image and use a different color for each external conductor. Also label the waveforms with the corresponding voltages. To do this, measure U_1 and U_2 as well as U_1 and U_3 simultaneously. State the oscilloscope settings you used.



$$L1: \frac{V}{DIV} =$$

$$L2: \frac{V}{DIV} =$$

$$L3: \frac{V}{DIV} =$$

$$\text{Time basis: } \frac{T}{DIV} =$$

Fig. 15

Draw now the phasor diagram of the voltages U_{L1-N} , U_{L2-N} and U_{L3-N} . Then complete your phasor diagram with the line-to-line voltages U_{L1-L2} , U_{L2-L3} and U_{L3-L1} . How large are these voltages?

$U_{L1} - U_{L2} =$

$U_{L2} - U_{L3} =$

$U_{L3} - U_{L1} =$

Fig. 16

The Three-Phase Midpoint Circuit

The circuit shown in figure 17 is a three-phase midpoint circuit. Build this three-phase rectifier circuit on the breadboard.

Warning: Pay attention not to include to short circuits via the oscilloscope **GND**() when building the circuit!

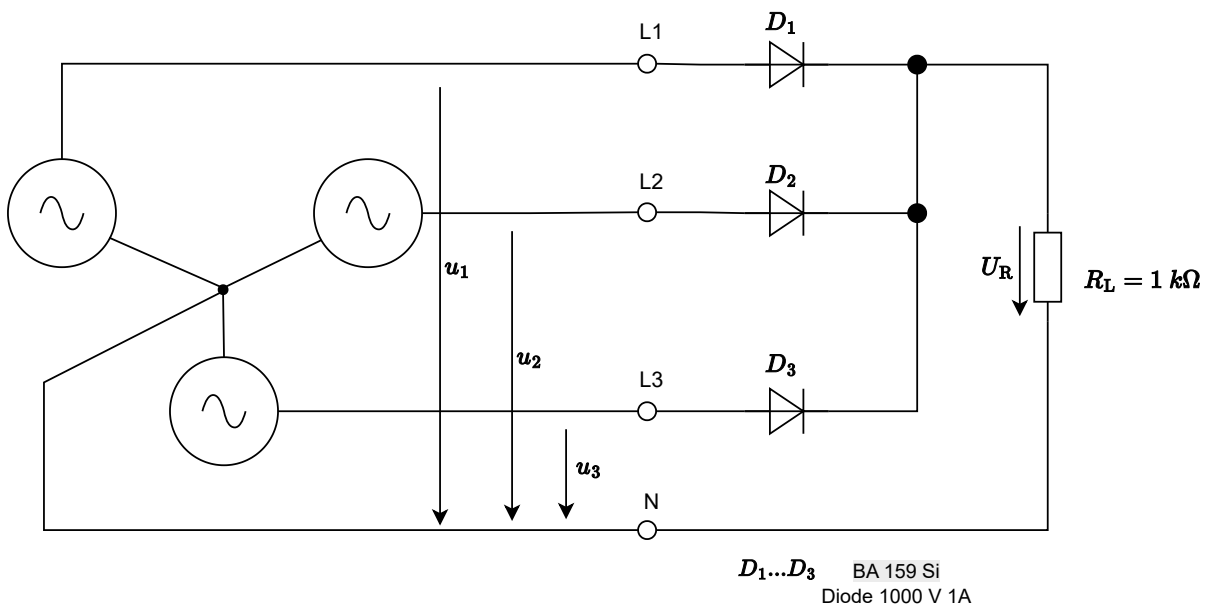

Fig. 17

Enter into the three-phase midpoint circuit, s. figure 17, the rectified voltage and the current. Now connect the oscilloscope to the built circuit so that the output voltage at the rectifier can be displayed together with U_1 or U_2 or U_3 . Label the waveforms with the corresponding voltages.
 Please draw the oscilloscope screen image in another color into the diagram figure 15.
 Which maximum and minimum values of the rectified voltage occur?

.....

What is the average value of the rectified voltage?

.....

How large is the ripple frequency?

.....

The Three-Phase Bridge Rectifier Circuit

Build the three-phase bridge rectifier circuit shown in figure 18 and enter the rectified voltage and the current into figure 18.

Warning: Pay attention to short circuits when building the circuit!

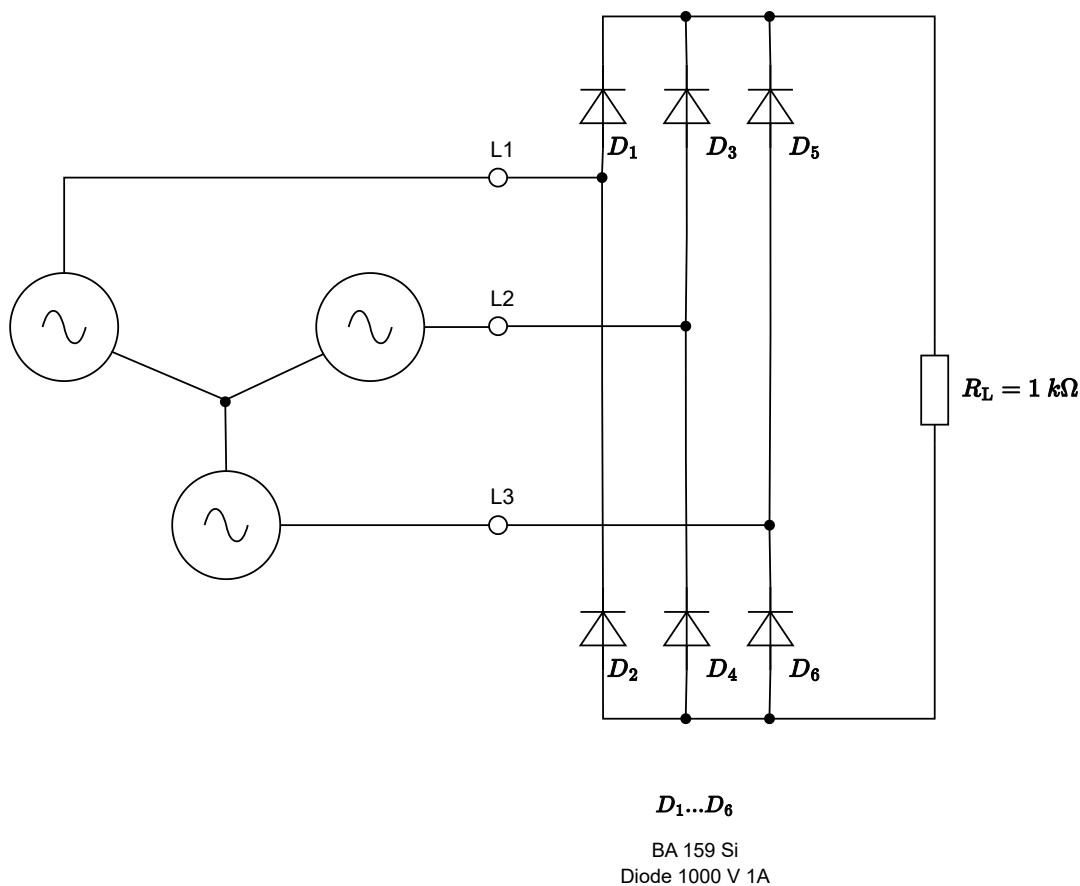
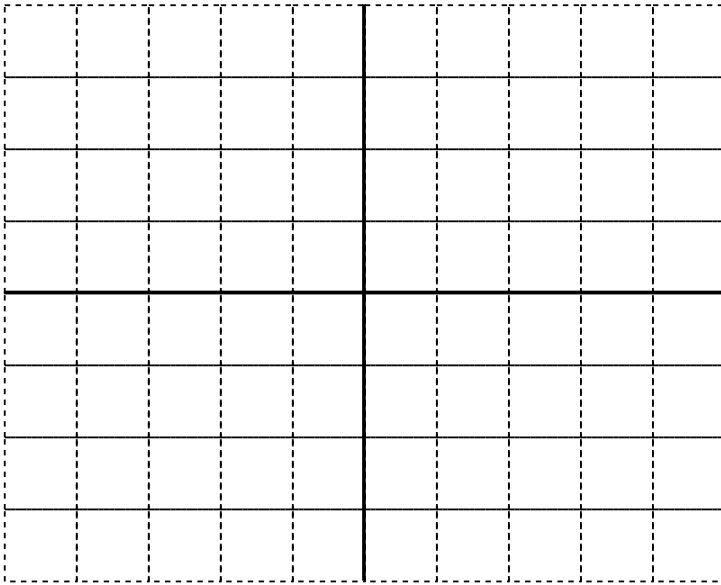

Fig. 18

Connect the oscilloscope so that the voltage after the three-phase bridge can be measured. Sketch the oscilloscope screen image, s. figure 19 and label the waveforms with the corresponding voltages. Give the oscilloscope settings used.



Channel 1: $\frac{V}{DIV} =$

Time basis: $\frac{T}{DIV} =$

Fig. 19

Which maximum and minimum values of the rectified voltage occur?

.....

What is the average value of the rectified voltage?

.....

How large is the ripple frequency?

.....

Now connect a capacitor (electrolytic capacitor) with 100 μF in parallel to the load resistor and sketch the oscilloscope screen image, s. figure 20. Label the waveforms with the corresponding voltages. Give the oscilloscope settings used:

.....

Warning: When using an electrolytic capacitor (Elko) the correct polarity must be observed!

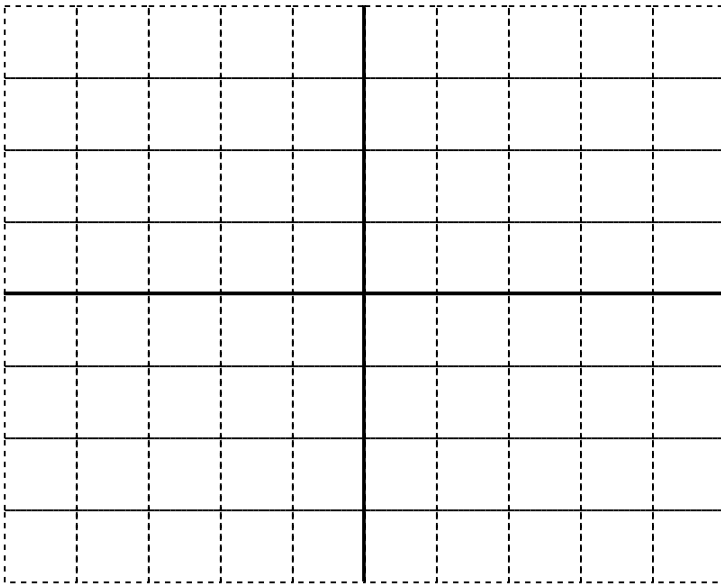

Channel 1: $\frac{V}{DIV} =$

Time basis: $\frac{T}{DIV} =$

Fig. 20

Which maximum and minimum values of the rectified voltage occur?

.....

What is the average value of the rectified voltage?

.....

How large is the ripple frequency?

.....

Finally, compare all measured circuits and explain the advantages and disadvantages of each circuit. Name one application for each circuit.

.....

.....

.....

.....

.....

.....