

exercise_sheet_1

Student Group

First Name	Surname	Matrikel Nr.

Table of Contents

Exercise 1.1.1 Microphone amplifier I 3
Exercise 1.1.2 Microphone amplifier II 5
Exercise 1.1.3 Wheatstone bridge circuit 6
Hint 8

Exercise 1.1.1 Microphone amplifier I

An amplifier circuit shall amplify a microphone signal in such a way that a loudspeaker ($R_{LS} = 8.0 \Omega$) can be driven. The **rms value** of the desired voltage across the loudspeaker shall be $U_{RMS,LS} = 10 \text{ V}$. It is assumed that a sinusoidal signal is to be output. The power is supplied by two voltage sources with $V_{S+} = 15 \text{ V}$ and $V_{S-} = -15 \text{ V}$. For understanding (especially for tasks 2. and 3.), look at the simulation under the subchapter **equivalent circuit** in chapter "1. amplifier basics". This example shows a realistic amplifier, but also the idealized current flow can be guessed from this.

1. Draw a labelled sketch of the circuit with the amplifier as a black box.
2. What power P does the loudspeaker consume?
3. From this, how can we determine the rms current $I_{RMS,S}$ of the power supply at which the above desired voltage $U_{RMS,LS}$ is output at the loudspeaker?

4. Determine from the previous task the maximum current $I_{\max,S}$ for which the two power supplies must be designed at least.
(Note that for simple amplifiers the output current I_O is always less than or equal to the current I_S of the power supply).

Exercise 1.1.2 Microphone amplifier II

A voltage amplifier circuit is given, which shall amplify a microphone signal in such a way that a loudspeaker ($R_{LS} = 8.0 \text{ } \Omega$) can be driven. Neither amplification nor the desired voltage at the loudspeaker is known. This amplifier circuit is internally protected against overcurrents above $I_{\text{max,amplifier}} = 5.0 \text{ A}$ by a fast fuse. It is known that no overcurrents occur in the allowed voltage operation of $8.0 \text{ } \Omega$ loudspeakers.

1. By what factor does the current change if a $4.0 \text{ } \Omega$ loudspeaker is used instead of an $8.0 \text{ } \Omega$ loudspeaker?

2. What effect does this have on the fuse?

Exercise 1.1.3 Wheatstone bridge circuit

Fig. 1: Wheatstone bridge circuit with a temperature sensor

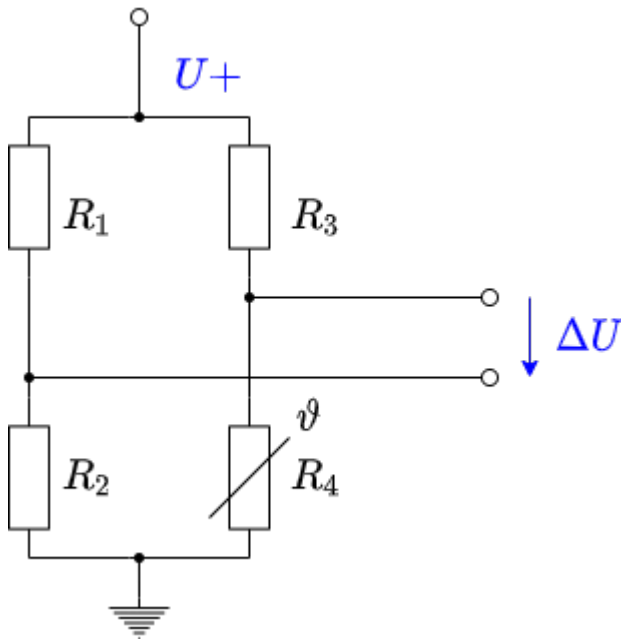

Imagine that you work in the company “HHN Mechatronics & Robotics”. You are developing an IoT system that will be used in a harsh environment and will contain a rechargeable battery. The temperature of the battery must be monitored during operation and charging. If the temperature is too high, charging must be aborted or a warning issued. For the temperature measurement at the housing of the used lithium-ion cell [NCR18650](#) a measuring circuit is to be built up. A suggestion for the circuit is as follows:

1. Wheatstone bridge circuit with $R_1 = R_2 = R_3 = R_4 = 1.0\text{k}\ \Omega$.
2. Let the resistor R_4 be a PT1000 with a temperature coefficient $\alpha = 3850\ \frac{\text{ppm}}{\text{K}}$.
3. For the other resistors, two components are chosen, that have an unknown temperature coefficient. According to the data sheet temperature coefficient is within $\alpha = \pm 100\ \frac{\text{ppm}}{\text{K}}$.
4. The voltage source of the system generates a voltage of 5V with sufficient accuracy.
5. The determined voltage ΔU is amplified by a factor of 20 through another amplifier circuit, output as U_{O} , and further used by an analog-to-digital converter in a microcontroller¹⁾.

A short report is to be created; Tina TI is to be used as the analysis tool.

1. Create a problem description.

2. Rebuild the circuit in TINA TI and add this here. Take the following hint into account.

Hint

Use a simple resistor for the PT1000 in the simulation. With Tina TI, 27°C (room temperature) is selected as the reference temperature for the temperature curve. For the PT1000, the reference temperature is often 0°C (in practical applications, this should be checked in the data sheet). With Tina TI, the reference temperature can be changed by entering the value 27 under Temperature [C] in the properties (double-click on Resistor).

3. From the data sheet linked above, determine in what range from T_{\min} to T_{\max} may be charged and what temperature T_{\lim} may not be exceeded in any of the states.

4. First, for temperature invariant $R_1 = R_2 = R_3 = 1.0k \Omega$ and a temperature variable resistor R_4 , determine the voltage change ΔU over the temperature of $-30 \dots 70^\circ\text{C}$ in TINA TI. To do this, create a plot with ΔU as a function of temperature.
Read $\Delta U^0(T_{\min})$, $\Delta U^0(T_{\max})$, $\Delta U^0(T_{\lim})$, from the diagram and check the plausibility of the values by calculation.

5. Determine ΔU when the temperature dependence of R_1 , R_2 and R_3 is taken into account. To do this, create a suitable diagram with ΔU as a function of temperature in TINA TI.
At what voltages $U_O(T_{\min})$, $U_O(T_{\max})$ must the microcontroller intervene and disable charging?
At what value $U_A(T_{\lim})$ must a warning be issued?

6. Discuss the results

¹⁾ In real systems, an analog-to-digital converter would most likely not be used because of its relatively large power consumption for IoT applications. For Atmel chips, this is a few $10\ \mu\text{A}$, which adds up to a rapid battery drain over time.

From:

<https://wiki.mexle.org/> - **MEXLE Wiki**

Permanent link:

https://wiki.mexle.org/circuit_design/exercise_sheet_1?rev=1636619597

Last update: **2021/11/11 09:33**

