

# uebungsblatt6

## Student Group

First Name	Surname	Matrikel Nr.

## Table of Contents

Exercise 4.2.1 Determination of the transmission behavior of the differential amplifier .....	3
Exercise 4.4.1 Transmission resistance of the current-voltage converter .....	4
Exercise 4.5.1 Transfer steepness of the voltage-current transformer .....	5
Exercise 4.5.2 Earth-related load .....	6



**Exercise 4.2.1 Determination of the transmission behavior of the differential amplifier**

In the following, the transfer function of the differential amplifier is to be calculated. To do this, you should follow a few steps.

1. Derive the function  $U_A = f(U_{E1}, U_{E2})$  using superposition.
  1. To do this, first draw an equivalent circuit in each case.
  2. Briefly describe the resulting circuit. Which amplification circuit results in each case?
  3. Then calculate the voltages  $U_{A1}$  and  $U_{A2}$ , and from them  $U_A$ .
2. Determine the function  $U_A = f(U_{E1}, U_{E2})$  or the resistance values of the circuit shown.

### Exercise 4.4.1 Transmission resistance of the current-voltage converter

Derive the gain for the current-voltage converter, i.e. the transmission resistance. Use the procedure that we used for the other amplifiers.

1. Draw a circuit with the relevant voltages, currents, resistances and the amplifiers
2. What are you looking for?
3. Number of variables
4. Number of equations required?
5. Establishing the known equations.
6. Derivation of the transmission resistance.

### Exercise 4.5.1 Transfer steepness of the voltage-current transformer

Here, too, derive the gain for the voltage-to-current transformer, i.e. the rate of transfer. Use the same procedure that we used for the other amplifiers.

1. Draw a circuit with the relevant voltages, currents, resistances and the amplifier.
2. What are you looking for?
3. number of variables?
4. number of necessary equations?
5. Establishing the known equations.
6. Derivation of the transmission slope.

### Exercise 4.5.2 Earth-related load

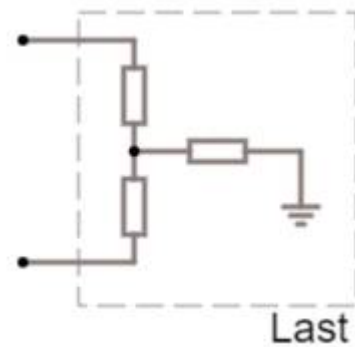

If the voltage-current converter is used as a current source, it must be ensured that the load has no contact with ground..

1. Draw the voltage-to-current transformer with a load that is in contact with ground.
2. In this case, why is the transmission slope derived above no longer valid as a gain factor?
3. Will the output current be higher or lower in this case?

From:

<https://wiki.mexle.org/> - **MEXLE Wiki**

Permanent link:

[https://wiki.mexle.org/circuit\\_design/uebungsblatt6?rev=1639049855](https://wiki.mexle.org/circuit_design/uebungsblatt6?rev=1639049855)

Last update: **2021/12/09 12:37**

