

aufgabe_2.7.8_mit_rechnung

Student Group

| First Name | Surname | Matrikel Nr. |
|------------|---------|--------------|
| | | |
| | | |
| | | |

Table of Contents

Exercise 2.7.8: Simplifying Circuits II (written exam task, approx 8% of a 60-minute written exam, WS2020) 2

Exercise 2.7.8: Simplifying Circuits II (written exam task, approx 8% of a 60-minute written exam, WS2020)

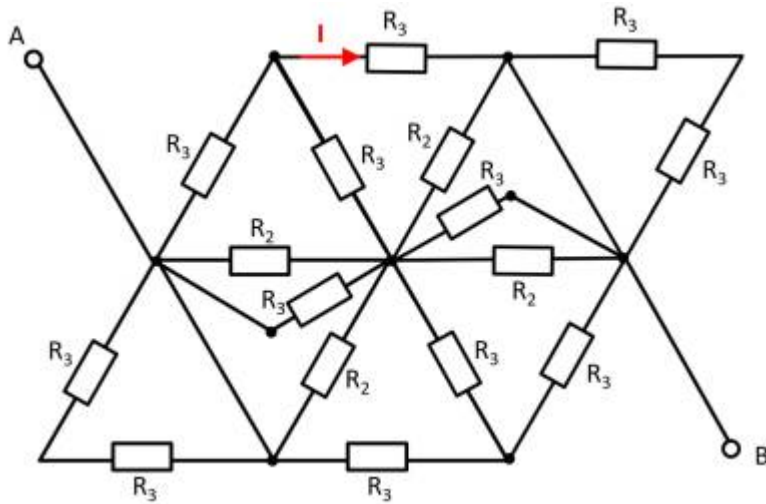

Given is the adjoining circuit with
 $R_1 = 5 \Omega$
 $R_2 = 10 \Omega$
 $R_3 = 20 \Omega$

1. Determine the equivalent resistance R_{eq} between A and B by summing the resistances.

Tips for solving

- How can the circuit be better represented or pulled apart?
- Switches (when used) should be replaced by an open or closed circuit.
- Does this result in equal potentials at different nodes that can be cleverly used?

Solution

First of all, it is a good idea to reshape the circuit so that the actual structure becomes visible. For this purpose, the individual branches can be highlighted in color and interpreted as a “conductive rubber band”.

It can be seen that the two resistors R_3 at the top left and bottom right are each shorted. The result is thus:



Here it helps to consider the potential of the nodes K1, K2, and K3. For K2, the resistances $R_2 \parallel R_3 \parallel R_2$ must be combined at the top and bottom. Thus, the same resistance values at the top and bottom result. Also at the nodes K1 and K2 the same resistance values at the top and at the bottom result. With the same ratios of the resistances at K1, K2, and K3 respectively, it can be concluded that no current flows across the resistors R_3 between K1 and K2 or K2 and K3. Thus, these do not contribute to the total resistance. In such a case, a short circuit or an open line can be freely chosen between the relevant nodes for the calculation. In the following, an open line is chosen. Additionally, the parallel strings can be reordered.

Fig. 1: Simulation

This results in:



$$R_{\text{eq}} = \left(\left(2 \cdot R_2 \right) \parallel \left(2 \cdot R_2 \right) \right) \parallel \left(\left(\left(2 \cdot R_3 \right) \parallel \left(2 \cdot R_3 \right) \parallel \left(2 \cdot R_3 \right) \right) \parallel R_3 \right)$$

$$R_{\text{eq}} = R_2 \parallel \left(R_3 \parallel \left(2 \cdot R_3 \right) \right)$$

$$R_{\text{eq}} = R_2 \parallel \frac{R_3 \cdot 2 R_3}{R_3 + 2 R_3}$$

$$R_{\text{eq}} = \frac{R_2 \cdot \frac{2}{3} R_3}{R_2 + \frac{2}{3} R_3} = \frac{R_2 \cdot R_3}{\frac{3}{2} R_2 + R_3}$$

Final result

$$R_{\text{eq}} = \frac{10 \text{ } \Omega \cdot 20 \text{ } \Omega}{\frac{3}{2} \cdot 10 \text{ } \Omega + 20 \text{ } \Omega} = 5.7143 \text{ } \Omega \rightarrow 5.7 \text{ } \Omega$$

2. Now let the voltage from A to B be: $U_{AB} = U_0 = 20 \text{ V}$. What is the current I ?

Solution

The partial current I is obtained directly from the voltage U_0 :

$$I = \frac{U_0}{2 \cdot R_3}$$

Final result

$$I = \frac{20 \text{ V}}{2 \cdot 20 \text{ } \Omega} = 0.5 \text{ A}$$

From: <https://wiki.mexle.org/> - MEXLE Wiki

Permanent link: https://wiki.mexle.org/ee1/aufgabe_2.7.8_mit_rechnung

Last update: 2023/03/19 19:04

