

# aufgabe\_4.5.2\_mit\_rechnung

## Student Group

First Name	Surname	Matrikel Nr.

## Table of Contents

Aufgabe 4.5.2: open circuit voltage via superposition (exam task, approx. 12 % of a 60-minute exam, WS2020) ..... 2

### Aufgabe 4.5.2: open circuit voltage via superposition (exam task, approx. 12 % of a 60-minute exam, WS2020)



A circuit is given with the following parameters

$$R_1 = 5 \, \Omega$$

$$U_1 = 2 \, \text{V}$$

$$I_2 = 1 \, \text{A}$$

$$R_3 = 20 \, \Omega$$

$$U_3 = 8 \, \text{V}$$

$$R_4 = 10 \, \Omega$$

Determine the open circuit voltage between A and B using the principle of superposition.

Tips

- What do the individual circuits look like, by which the effects of the individual sources can be calculated?  
Which equivalent resistor must be used to replace a current or voltage source when calculating the individual effects?
- Where are the open-circuit voltages applied when looking at the individual components?

Solution

First, the individual circuits must be created, from which the effect of the individual sources between points A and B can be determined.

#### (Voltage) source $U_1$

- substitute the current source  $I_2$  with a short-circuit
- substitute the voltage source  $U_3$  with an open circuit

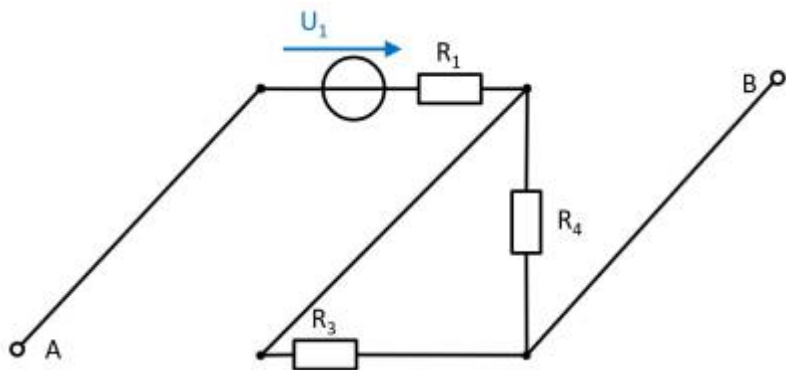

The components can be moved in order to understand the circuit s bit better.

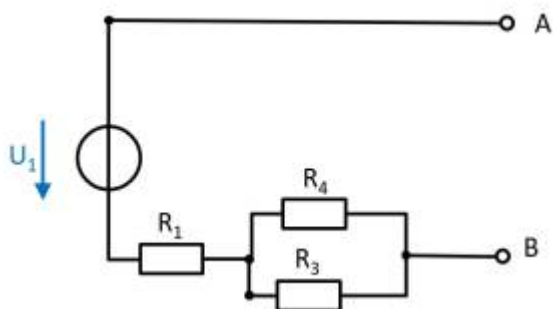

For the open circuit, no current is flowing through any resistor. Therefore, the effect is:  
 $U_{AB,1} = U_1$

**(current) source  $I_2$**

- substitute the voltage source  $U_1$  with an open circuit
- substitute the voltage source  $U_3$  with an open circuit

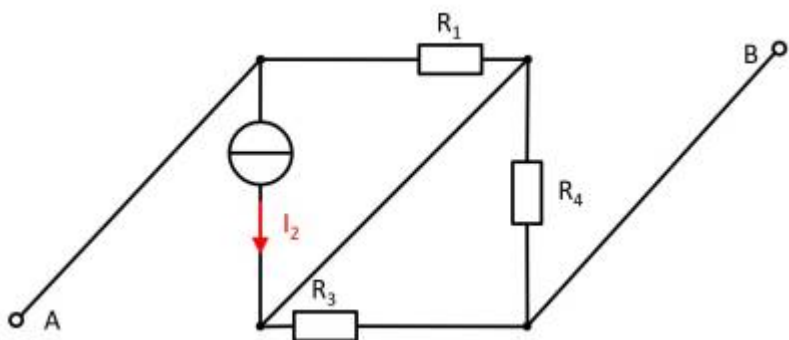

Also here, the components can be shifted for a better understanding:



Here, the current source  $I_2$  creates a voltage drop  $U_{AB,2}$  on the resistor  $R_2$  :  
 $U_{AB,2} = - R_2 \cdot I_2$

**(Voltage) source  $U_3$**

- substitute the voltage source  $U_1$  with an open circuit
- substitute the current source  $I_2$  with a short-circuit

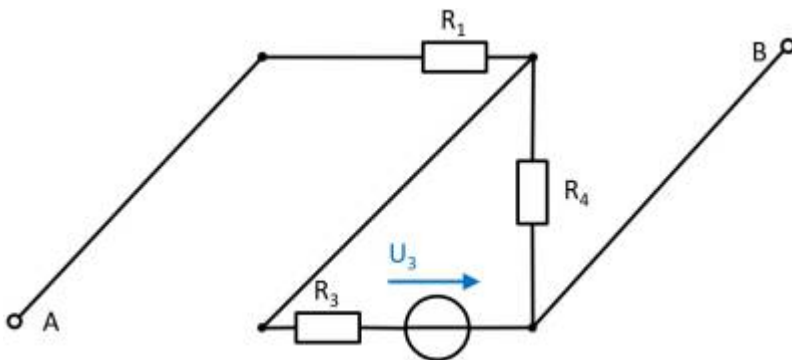

Again, rearranging the circuit might help for an understanding:

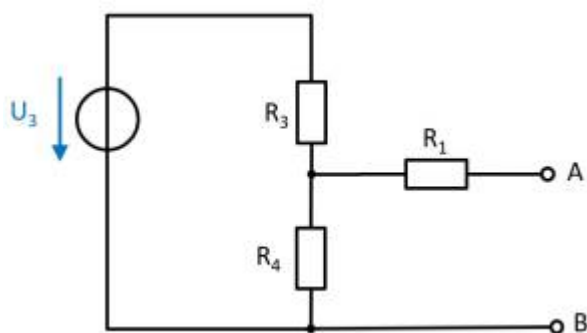

In this case, between the unloaded outputs  $A$  and  $B$  there will be an unloaded voltage divider given by  $R_3$  and  $R_4$ . On  $R_1$  there is no voltage drop since there is no current flow out of the unloaded outputs.

Therefore:

$$U_{AB,3} = \frac{R_4}{R_3 + R_4} \cdot U_3$$

**resulting voltage**

$$\begin{aligned} U_{\text{AB}} &= U_1 - R_1 \cdot I_2 + \frac{R_4}{R_3 + R_4} \cdot U_3 \\ \end{aligned}$$

Final value

$$\begin{aligned} U_{\text{AB}} &= 2 \text{ V} - 5 \Omega \cdot 1 \text{ A} + \frac{10}{20 \Omega + 10 \Omega} \cdot 8 \text{ V} \\ U_{\text{AB}} &= 0.333 \text{ V} \end{aligned}$$

From:

<https://wiki.mexle.org/> - **MEXLE Wiki**

Permanent link:

[https://wiki.mexle.org/ee1/aufgabe\\_4.5.2\\_mit\\_rechnung](https://wiki.mexle.org/ee1/aufgabe_4.5.2_mit_rechnung)

Last update: **2023/03/23 14:17**

