

Block 19 — Magnetic Circuits and Inductance

Student Group

First Name	Surname	Matrikel Nr.

Table of Contents

Block 19 — Magnetic Circuits and Inductance	3
19.0 Intro	3
19.0.1 Learning objectives	3
19.0.2 Preparation at Home	3
19.0.3 90-minute plan	3
19.0.4 Conceptual overview	3
19.1 Core content	3
19.1.2 Basics for Linear Magnetic Circuits	4
Current-carrying Coil	7
Ferrite Core	7
Airgap	7
19.1.2 Reluctance - the magnetic Resistance	7
19.1.3 Applications of Flux and Reluctance	10
Core with Airgap	10
Electric Magnet with three Legs	12
Notice:	13
19.2 Common pitfalls	14
19.3 Exercises	14
Exercise E10 Magnetic Circuit (written test, approx. 7 % of a 120-minute written test, SS2022)	14
Exercise E10 Magnetic Circuit (written test, approx. 9 % of a 120-minute written test, SS2024)	15
Exercise E1 Cylindrical Coil (written test, approx. 6 % of a 120-minute written test, SS2021)	17
Exercise 5.1.1 Coil on a plastic Core	18
Exercise 5.1.2 magnetic Resistance of a cylindrical coil	18
Exercise 5.1.3 magnetic Resistance of an airgap	19
Exercise 5.1.4 Magnetic Voltage	19
Exercise 5.1.5 Magnetic Flux	19

Exercise 5.1.6 Two-parted ferrite Core	20
Exercise 5.1.7 Comparison with simplified Calculation	22
Exercise 5.1.8 Coil on a ferrite Core with airgap	22
Exercise 5.3.3 toroidal Core with two Coils	23
Embedded resources	27

Block 19 — Magnetic Circuits and Inductance

19.0 Intro

19.0.1 Learning objectives

After this 90-minute block, you can

- ...

19.0.2 Preparation at Home

Well, again

- read through the present chapter and write down anything you did not understand.
- Also here, there are some clips for more clarification under 'Embedded resources' (check the text above/below, sometimes only part of the clip is interesting).

For checking your understanding please do the following exercises:

- Exercise E2 Magnetic Circuit
- Exercise 5.1.4 Magnetic Voltage
- Exercise 5.1.7 Comparison with simplified Calculation

19.0.3 90-minute plan

1. Warm-up (x min):
 1.
2. Core concepts & derivations (x min):
 1. ...
3. Practice (x min): ...
4. Wrap-up (x min): Summary box; common pitfalls checklist.

19.0.4 Conceptual overview

1. ...

19.1 Core content

For this and the following chapter the online Book 'DC Electrical Circuit Analysis - A Practical Approach' is strongly recommended as a reference. In detail this is chapter [10.3 Magnetic Circuits](#)

In the previous chapters, we got accustomed to the magnetic field. During this path, some similarities from the magnetic field to the electric circuit appeared (see [figure 1](#)).

Fig. 1: Similarities magnetic Circuit vs electric Circuit

In this chapter, we will investigate how far we have come with such an analogy and where it can be practically applied.

19.1.2 Basics for Linear Magnetic Circuits

For the upcoming calculations, the following assumptions are made

1. The relationship between B and H is linear: $B = \mu \cdot H$
This is a good estimation when the magnetic field strength lays well below saturation

2. There is no stray field leaking out of the magnetic field conducting material.
3. The fields inside of airgaps are homogeneous. This is true for small air gaps.

One can calculate a lot of simple magnetic circuits when these assumptions are applied and focusing on the average field line are applied.

The average field line has the length of l

Fig. 2: Simplifications and Linearization

Two simple magnetic circuits are shown in [figure 3](#): They consist of

- a current-carrying coil
- a ferrite core
- an airgap (in picture (2) + (3)).

Fig. 3: A simple magnetic Circuit

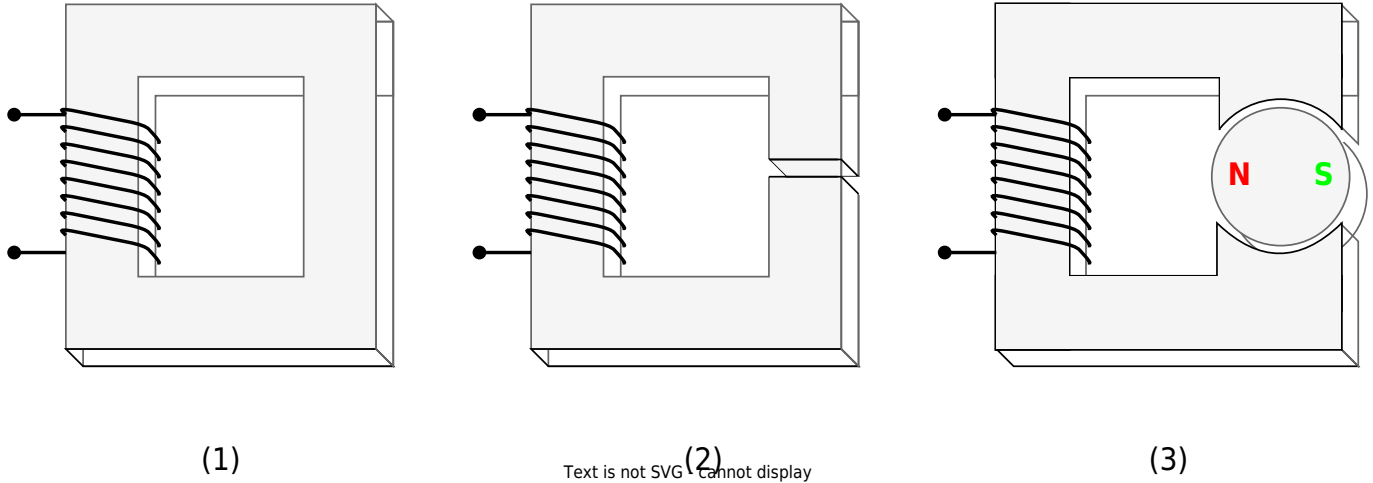

These three parts will be investigated shortly:

Current-carrying Coil

For the magnetic circuit, the coil is parameterized only by:

- its number of windings N and
- the passing current i .

These parameters lead to the magnetic voltage $\theta = N \cdot i$.

Ferrite Core

- The core is assumed to be made of ferromagnetic material.
- Therefore, the relative permeability in the core is much larger than in air ($\mu_{r, \text{core}} \gg 1$).
- The ferrite core is also filling the inside of the current-carrying coil.
- The ferrite core conducts the magnetic flux around the magnetic circuit (and by this: also to the airgap)

Airgap

- The air gap interrupts the ferrite core.
- The width of the air gap is small compared to the dimensions of the cross-section of the ferrite core.
- The field in the air gap can be used to generate (mechanical) effects within the air gap. An example of this can be the force onto a permanent magnet (see [figure 3 \(3\)](#)).

We also assume that the magnetic flux Φ remains constant along the ferrite core and in the air gap, so $\Phi_{\text{airgap}} = \Phi_{\text{core}} = \text{const.}$

19.1.2 Reluctance - the magnetic Resistance

Let's have a look at the simplest situation:

Fig. 1: the simple magnetic circuit

What do we know about this circuit?

1. The length of the average field line is l .
The cross-sectional area shall be constant: $A = \text{const.}$
2. magnetic voltage:
$$\theta = H \cdot l \tag{1}$$
3. magnetic flux:
$$\Phi = B \cdot A \tag{2}$$
4. relationship between the two fields:
$$B = \mu H \tag{3}$$

This can now be combined. Let us start with (3) in (2) and then take this result to divide (1) by it:

$$\Phi = \mu H \cdot A \tag{4}$$

$$\frac{\theta}{\Phi} = \frac{H \cdot l}{\mu H \cdot A} = \frac{l}{\mu \cdot A} \tag{5}$$

Hmm.. what have we done here? We divided the voltage by the flux, similar to $\frac{U}{I}$ and

we got something only depending on the dimensions and material.

We might see some similarities here:

$$\begin{aligned} \frac{U}{I} = \rho \cdot \frac{l}{A} = R \quad \text{\textit{for the electric circuit}} \\ \end{aligned}$$

$$\begin{aligned} \boxed{\frac{\theta}{\Phi} = \frac{l}{\mu} \cdot \frac{1}{A} = R_m} \quad \text{\textit{for the magnetic circuit}} \\ \end{aligned}$$

The quantity R_m is called **reluctance or magnetic resistance**.

The unit of R_m is $[R_m] = \frac{\theta}{\Phi} = \frac{\text{Vs}}{\text{A}} = 1/H$

- The length l is given by the mean magnetic path length (= average field line length in the core).
- Kirchoff's laws (mesh rule and nodal rule) can also be applied:
 - The sum of the magnetic fluxes Φ_i in into a node is: $\sum_i \Phi_i = 0$
 - The sum of the magnetic voltages θ_i along the average field line is: $\sum_i \theta_i = 0$
- The application of the lumped circuit model is based on multiple assumptions. In contrast to the simplification for the electric current and voltage the simplification for the flux and magnetic voltage is not as exact.

So, we got an equivalent magnetic circuit:

19.1.3 Applications of Flux and Reluctance

Core with Airgap

Another common situation is to have a air gap separating the iron core.

The width of air gaps are commonly given by δ .

The flux in the air gap and the core is the same, but the permeability μ differs strongly.

Fig. 5: lumped Circuit Model for a simple magnetic Circuit

If it would be an electrical circuit, we would get for the source voltage U_S

$$\begin{aligned} U_S &= U_1 + U_2 \\ &= R_1 \cdot I + R_2 \cdot I \\ &= \rho_1 \frac{l_1}{A} \cdot I + \rho_2 \frac{l_2}{A} \cdot I \end{aligned}$$

The resulting formula for the magnetic voltage θ is similar:

$$\begin{aligned} \theta &= \theta_1 + \theta_2 \\ &= R_{m,1} \cdot \Phi + R_{m,2} \cdot \Phi \\ &= \frac{1}{\mu_0 \mu_{r,\text{core}}} \frac{l_{\text{core}}}{A} \cdot \Phi + \frac{1}{\mu_0 \mu_{r,\text{airgap}}} \frac{\Delta}{A} \cdot \Phi \end{aligned}$$

Additionally, the magnetic voltage θ is given by:
$$\theta = N \cdot I$$

Given the relationship $B = \mu \cdot H$, and $\mu_{\text{core}} \gg \mu_{\text{airgap}}$, we can conduct that H -Field must be much stronger within the airgap (figure 6 (3)).

Fig. 6: B- and H-field along the ferrite core



Electric Magnet with three Legs

Fig. 7: Lumped Circuit Model for a complex magnetic Circuit

Assuming that μ is constant, we get the following:

Fig. 8: lumped Circuit Model for a complex magnetic Circuit

+-----+ +-----+

With the reluctances:

$$\begin{aligned} R_{m,x} = \frac{1}{\mu_0 \mu_{r,x}} \frac{l_x}{A} \end{aligned}$$

Notice:

Sections with ...

- constant flux Φ
- constant cross-sectional area A
- constant material μ_r

... can be subsumed to a lumped magnetic resistans (reluctance)!

19.2 Common pitfalls

- ...

19.3 Exercises

Exercise E10 Magnetic Circuit

(written test, approx. 7 % of a 120-minute written test, SS2022)

The magnetic setup below shall be given. Draw the equivalent magnetic circuit to represent the setup fully. Name all the necessary magnetic resistances, fluxes, and voltages. The components shall be designed in such a way, that the magnetic resistance is constant in it.

Formulas are not necessary.

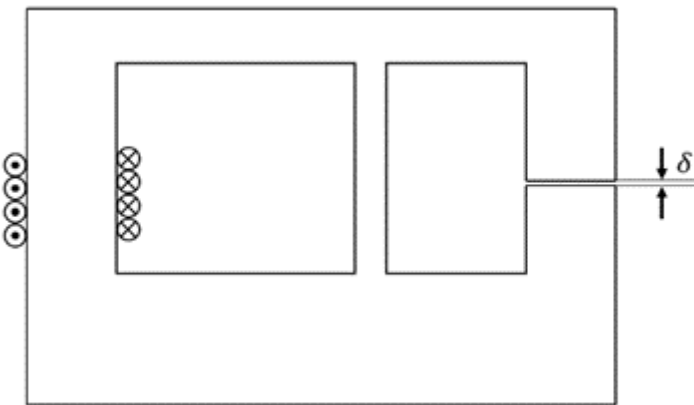

Path

Watch for parts of the magnetic circuit, where the width and material are constant. These parts represent the magnetic resistors which have to be calculated individually. Be aware, that every junction creates a branch with a new resistor, like for an electrical circuit - there must be a node on each "diversion".

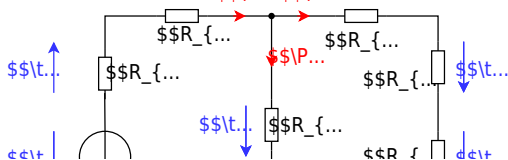
$$R_{\text{m}} = \frac{l}{\mu_0 \mu_r w \cdot h}$$

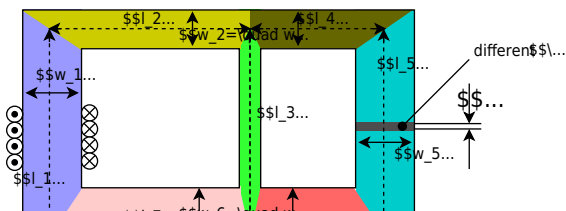

Exercise E10 Magnetic Circuit
 (written test, approx. 9 % of a 120-minute written test, SS2024)

1. Calculate the magnetic resistance of a magnetic circuit with a cross-sectional area of $A=300 \text{ mm}^2$ and an average circumference of $l=3 \text{ dm}$.

Path

$$R_m = \frac{l}{\mu_0 \mu_r I} = \frac{3 \text{ dm}}{0.884 \cdot 10^6 \text{ Vs/Am} \cdot 1} = 3.39 \cdot 10^{-6} \text{ Vs/Am}$$

First we have to calculate the magnetic resistance in a region μ_r based on the sources:

$$\mu_r = \frac{\mu}{\mu_0} = \frac{4\pi \cdot 10^{-7} \text{ Vs/Am} \cdot 300 \text{ mm}^2}{4\pi \cdot 10^{-7} \text{ Vs/Am} \cdot 300 \text{ mm}^2} = 300$$

To get the flux Φ , the Hopkinson's Law can be applied - similar to the Ohm's Law:

$$\Phi = \frac{I}{R_m} = \frac{60 \text{ A}}{3.39 \cdot 10^{-6} \text{ Vs/Am}} = 1.77 \cdot 10^7 \text{ Vs}$$

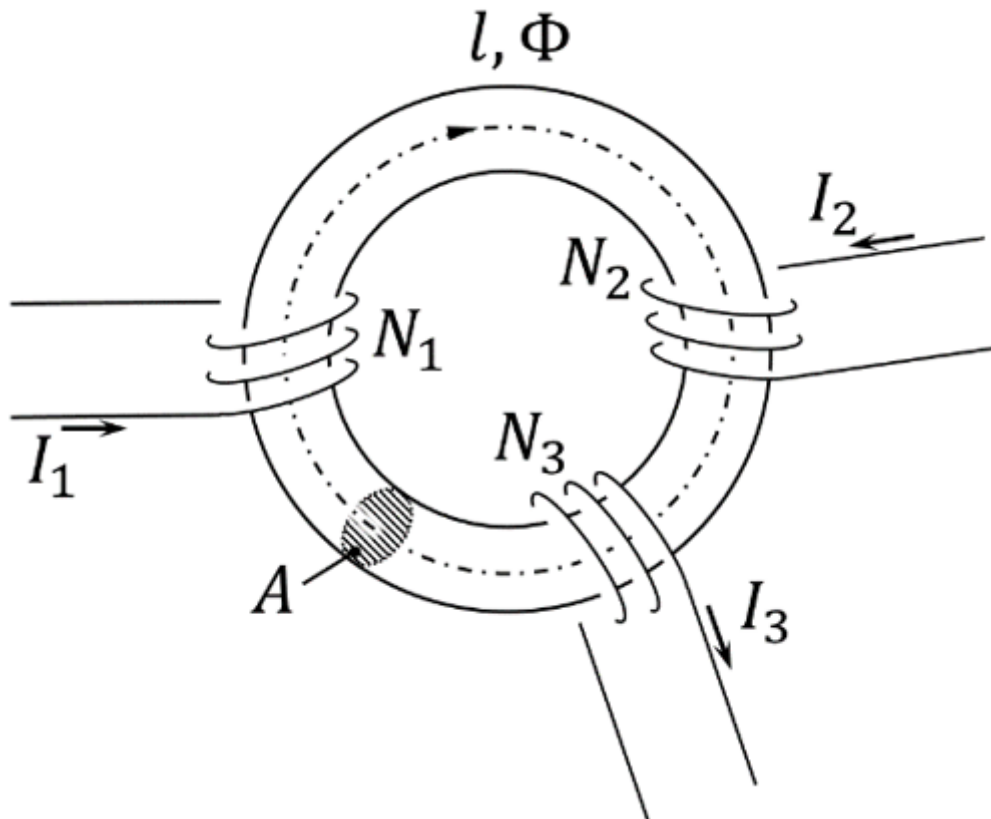

On the core, there are three coils with:

- Coil 1: $N_1 = 1200$, $I_1 = 100 \text{ mA}$
- Coil 2: $N_2 = 33$, $I_2 = 3 \text{ A}$
- Coil 3: $N_3 = 270$, $I_3 = 0.3 \text{ A}$

Refer to the drawing for the direction of the windings, current, and flux!

1. Draw the equivalent magnetic circuit that fully represents the setup. Name all the necessary magnetic resistances, fluxes, and voltages.

Result

- Since the material, and diameter of the core is constant, one can directly simplify the magnetic resistor into a single $R \text{ m}$.
- For the orientation of the magnetic voltages θ_1 , θ_2 , and θ_3 , the orientation of the coils and the direction of the current has to be taken into account by the right-hand rule.
- There is only one flux Φ
- The magnetic voltages are antiparallel to the flux for sources and parallel for the load.



Exercise E1 Cylindrical Coil
 (written test, approx. 6 % of a 120-minute written test, SS2021)

a) The magnetic flux (2 points) Information is given:

Result

- Length $l = 30 \text{ cm}$,

Path Winding diameter $d = 390 \text{ mm}$,

- Number of windings $N = 240$,
- Current through the inductor $I = 500 \text{ mA}$,

- Material inside: Air

$\mu_0 = 4\pi \cdot 10^{-7} \text{ Vs/Am}$

The magnetic field strength is $B = \mu_0 \mu_r \cdot H$:

The proportion of the magnetic voltage outside the coil can be neglected. Determine the following for the inside of the coil:

a) Determine the magnetic field strength (2 points)

$A = \pi r^2 = \pi \left(\frac{d}{2} \right)^2$

Path

Therefore: $\Phi = B \cdot \pi \left(\frac{d}{2} \right)^2$

Putting in the numbers:
$$\Phi = 0.0005026... \frac{\text{Vs}}{\text{m}^2} \cdot \pi \left(\frac{0.39 \text{ m}}{2} \right)^2 \approx 0.00006004... \text{ Vm}$$

Putting in the numbers:
$$H = \frac{240 \cdot 0.5 \text{ A}}{0.3 \text{ m}}$$

Exercise 5.1.1 Coil on a plastic Core

A coil is set up onto a toroidal plastic ring ($\mu_r=1$) with an average circumference of $l_R = 300 \text{ mm}$. The $N=400$ windings are evenly distributed along the circumference. The diameter on the cross-section of the plastic ring is $d = 10 \text{ mm}$. In the windings, a current of $I=500 \text{ mA}$ is flowing.

Calculate

1. the magnetic field strength H in the middle of the ring cross-section.
2. the magnetic flux density B in the middle of the ring cross-section.
3. the magnetic resistance R_m of the plastic ring.
4. the magnetic flux Φ .

Result

1. $H = 667 \frac{\text{A}}{\text{m}}$
2. $B = 0.84 \text{ mT}$
3. $R_m = 3 \cdot 10^9 \frac{1}{\text{H}}$
4. $\Phi = 66 \text{ nVs}$

Exercise 5.1.2 magnetic Resistance of a cylindrical coil

Calculate the magnetic resistances of cylindrical coreless (=ironless) coils with the following dimensions:

1. $l=35.8 \text{ cm}$, $d=1.90 \text{ cm}$
2. $l=11.1 \text{ cm}$, $d=1.50 \text{ cm}$

Solution:

1. $1.00 \cdot 10^9 \frac{1}{\text{H}}$
2. $0.50 \cdot 10^9 \frac{1}{\text{H}}$

The magnetic resistance is given by:
$$R_m = \frac{1}{\mu_0 \mu_r} \frac{l}{A}$$

With

- the area $A = \left(\frac{d}{2} \right)^2 \cdot \pi$

- the vacuum magnetic permeability $\mu_0 = 4\pi \cdot 10^{-7} \text{ H/m}$, and
- the relative permeability $\mu_r = 1$.

Exercise 5.1.3 magnetic Resistance of an airgap

Calculate the magnetic resistances of an airgap with the following dimensions:

1. $\delta = 0.5 \text{ mm}$, $A = 10.2 \text{ cm}^2$
2. $\delta = 3.0 \text{ mm}$, $A = 11.9 \text{ cm}^2$

Result

1. $3.9 \cdot 10^5 \text{ H}^{-1}$
2. $2.0 \cdot 10^6 \text{ H}^{-1}$

Exercise 5.1.4 Magnetic Voltage

Calculate the magnetic voltage necessary to create a flux of $\Phi = 0.5 \text{ mVs}$ in an airgap with the following dimensions:

1. $\delta = 1.7 \text{ mm}$, $A = 4.5 \text{ cm}^2$
2. $\delta = 5.0 \text{ mm}$, $A = 7.1 \text{ cm}^2$

Result

1. $\theta = 1.5 \cdot 10^3 \text{ A}$, or 1000 windings with 1.5 A
2. $\theta = 2.8 \cdot 10^3 \text{ A}$, or 1000 windings with 2.8 A

Exercise 5.1.5 Magnetic Flux

Calculate the magnetic flux created on a magnetic resistance of $R_m = 2.5 \cdot 10^6 \text{ H}^{-1}$ with the following magnetic voltages:

1. $\theta = 35 \text{ A}$
2. $\theta = 950 \text{ A}$
3. $\theta = 2750 \text{ A}$

Result

1. $\Phi = 14 \text{ } \mu\text{Vs}$
2. $\Phi = 0.38 \text{ mVs}$
3. $\Phi = 1.1 \text{ mVs}$

Exercise 5.1.6 Two-parted ferrite Core

A core shall consist of two parts, as seen in [figure 9](#). In the coil, with 600 windings shall pass the current $I = 1.30 \text{ A}$.

The cross sections are $A_1 = 530 \text{ mm}^2$ and $A_2 = 460 \text{ mm}^2$. The mean magnetic path lengths are $l_1 = 200 \text{ mm}$ and $l_2 = 130 \text{ mm}$.

The air gaps on the coupling joint between both parts have the length $\delta = 0.23 \text{ mm}$ each. The permeability of the ferrite is $\mu_r = 3000$. The cross-section area A_{δ} of the airgap can be considered the same as A_2 .

Fig. 9: Two-parted ferrite Core



1. Draw the lumped circuit of the magnetic system
2. Calculate all magnetic resistances $R_{\text{m},i}$
3. Calculate the flux in the circuit

Result

1. -
2. magnetic resistances: $R_{\text{m},1} = 100 \cdot 10^3 \text{ ~\rm \frac{1}{H}}$, $R_{\text{m},2} = 75 \cdot 10^3 \text{ ~\rm \frac{1}{H}}$, $R_{\text{m},\Delta} = 400 \cdot 10^3 \text{ ~\rm \frac{1}{H}}$
3. magnetic flux: $\Phi = 0.80 \text{ ~\rm mVs}$

Exercise 5.1.7 Comparison with simplified Calculation

The magnetic circuit in [figure 10](#) passes a magnetic flux density of 0.4 T given by an excitation current of 0.50 A in 400 windings. At position $A-B$, an air gap will be inserted. After this, the same flux density will be reached with 3.70 A

Fig. 10: Example of a magnetic circuit

-
1. Calculate the length of the airgap δ with the simplification $\mu_{\text{r}} \gg 1$
 2. Calculate the length of the airgap δ exactly with $\mu_{\text{r}} = 1000$

Result

1. $\delta = 4.02(12) \text{ mm}$
2. $\delta = 4.02(52) \text{ mm}$

Exercise 5.1.8 Coil on a ferrite Core with airgap

The choke coil shown in [figure 11](#) shall be given, with a constant cross-section in all legs

I_0 , I_1 , I_2 . The number of windings shall be N and the current through a single winding I .

Fig. 11: Example for a Choke Coil

↑ ↑ ↑ ↑

1. Draw the lumped circuit of the magnetic system
2. Calculate all magnetic resistances $R_{\{\text{m}\},i}$
3. Calculate the partial fluxes in all the legs of the circuit

Exercise 5.3.3 toroidal Core with two Coils

Result A toroidal core (ferrite, $\mu_{\text{r}} = 900$) has a cross-sectional area of $A = 500 \text{ mm}^2$ and an average circumference of $l = 280 \text{ mm}$. At the core, there are two coils $N_1 = 500$ and $N_2 = 250$ wound. The currents on the coils are $I_1 = 250 \text{ mA}$ and $I_2 = 300 \text{ mA}$.

1. The coils shall pass the currents with positive polarity (see the image **A** in figure 12).
What is the resulting magnetic flux Φ_{A} in the coil?
2. The coils shall pass the currents with negative polarity (see the image **B** in figure 12).
What is the resulting magnetic flux Φ_{B} in the coil?

Fig. 12: toroidal core with two coils in positive and negative polarity

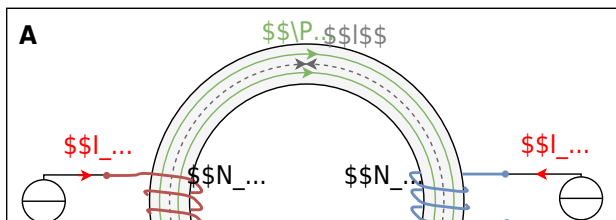

Solution

The resulting flux can be derived from a superposition of the individual fluxes $\Phi_1(I_1)$ and $\Phi_2(I_2)$, or alternatively by summing the magnetic voltages in

the loop ($\sum_x \theta_x = 0$).

Step 1 - Draw an equivalent magnetic circuit

Since there are no branches, all of the core can be lumped into a single magnetic resistance (see figure 13).

Fig. 13: equivalent magnetic circuit

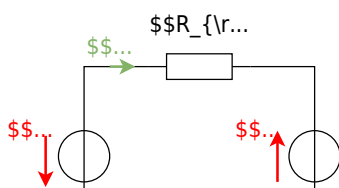

Step 2 - Get the absolute values of the individual fluxes

Hopkinson's Law can be used here as a starting point. It connects the magnetic flux Φ and the magnetic voltage θ on the single magnetic resistor R_m . It also connects the single magnetic fluxes Φ_x (with $x = \{1,2\}$) and the single magnetic voltages θ_x .

$$\begin{aligned} \theta_x &= R_m \cdot \Phi_x \cdot N_x \cdot I_x = \\ & \frac{1}{\mu_0 \mu_r} \frac{l}{A} \cdot \Phi_x \cdot N_x \cdot I_x = \frac{1}{R_m} \cdot N_x \cdot I_x \end{aligned}$$

With the given values we get: $R_{\text{m}} = 495 \frac{\text{kA}}{\text{Vs}}$

Step 3 - Get the signs/directions of the fluxes

The figure 14 shows how to get the correct direction for every single flux by use of the right-hand rule. The fluxes have to be added regarding these directions and the given direction of the flux in question.

Fig. 14: toroidal core with two coils in positive and negative polarity

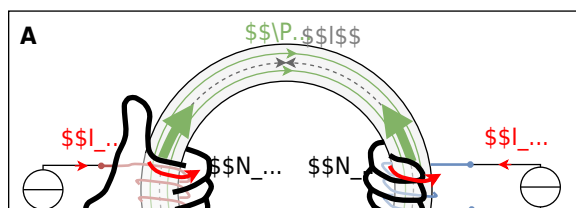

Therefore, the formulas are

$$\Phi_{\text{A}} = \Phi_1 - \Phi_2 = \frac{1}{R_{\text{m}}} \cdot (N_1 \cdot I_1 - N_2 \cdot I_2) = 0.25 \text{ mVs} - 0.15 \text{ mVs} = \Phi_{\text{B}} = \Phi_1 + \Phi_2 = \frac{1}{R_{\text{m}}} \cdot (N_1 \cdot I_1 + N_2 \cdot I_2) = 0.25 \text{ mVs} + 0.15 \text{ mVs}$$

Embedded resources

Practical Application of calculation in magnetics

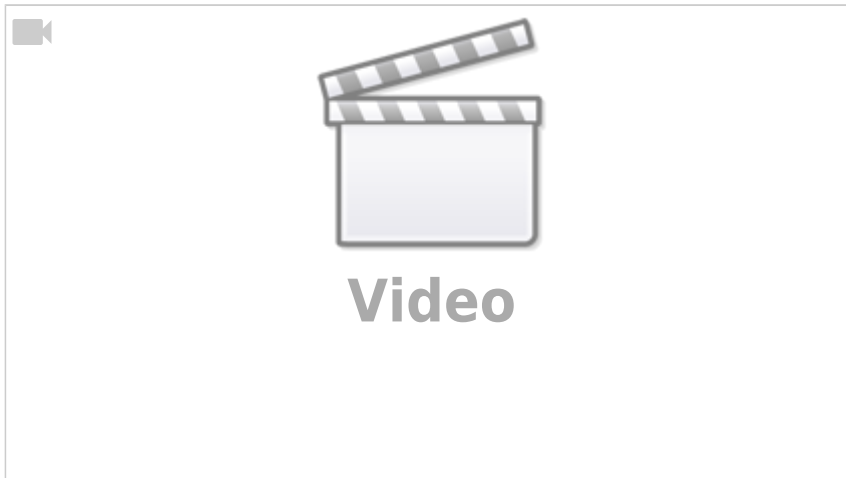

Practical Application of calculation in magnetics
(examples)

1. [investigation_of_permanent_magnet_sync_hronous_mach.pdf](#)
2. [Estimation of losses in the stator and rotor of interior permanent magnets synchronous \(IPMs\) machines using reluctance network Reluctance](#)
3. [Comparison of Motor Stator and Rotor Technologies of Tesla, BYD, and Huawei](#)

From:

<https://wiki.mexle.org/> - **MEXLE Wiki**

Permanent link:

https://wiki.mexle.org/electrical_engineering_and_electronics_1/block19

Last update: **2026/01/10 10:22**

