

# 5 Storage Elements

## Student Group

First Name	Surname	Matrikel Nr.

## Table of Contents

- 5 Storage Elements** ..... 2
- 5.1 Evolution of a Flip-Flop** ..... 2
  - 5.1.1 Flip-Flop as a Blackbox ..... 2
  - 5.1.2 RS Flip-Flop - Open the Blackbox ..... 3
  - 5.1.3 D-Latch - Solving the Inconsistencies ..... 4
  - 5.1.4 Edge-Triggered D Flip-Flop - One at a time ..... 5
  - 5.1.5 JK Flip-Flop - The Alternative to the undefined Behavior ..... 7
  - 5.1.6 T Flip-Flop - changeable, when wanted ..... 7
- 5.2 Convertibility of Flip-Flops** ..... 8
  - 5.2.1 Look onto the problem + Reduce it down to the relevant part ..... 8
  - 5.2.2 Build up a detailed truth table + look onto the relevant outputs ..... 9
  - 5.2.3 Fill in and use a Karnaugh map + Create the logic circuit ..... 10
- 5.3 Applications of Flip-Flops** ..... 11
  - 5.3.1 Data Register ..... 12
    - Exercise 5.3.1.1 Data Register ..... 12
  - 5.3.2 Shift Register ..... 13
    - Exercise 5.3.2.1 Shift Register ..... 13
  - 5.3.3 Frequency Divider ..... 13
    - Exercise 5.3.3.1 Frequency Divider ..... 14
  - 5.3.4 Up-Counter ..... 14
    - Exercise 5.3.4.1 Up-Counter ..... 15
    - Exercise 5.3.4.2 Designing an Up-Counter ..... 15
- Examples** ..... 15
- Exercises** ..... 16
  - Exercise 5.4.1.1 Flip Flops Timing Sequence ..... 16
- further Links** ..... 17

# 5 Storage Elements

In the previous chapter, we had a look at memory devices, which store data even when no voltage is applied. This is great for long-term storage, like measurement data, pictures, or music. The clock frequency of the storage element is often much lower than the internal frequency of the processor/controller. By this, the processor has to wait for the stored information due to high access time.

Therefore a controller-internal memory is advantageous. These are often called cache. Distinct storage elements have special properties, e.g. the written data changes the logic level of a pin ('foot') of the IC directly. We will now focus on these controller-internal, fast memory, which consists of logic gates.

The name flip-flop stems from the fact, that the smallest logic circuit for storing data has to store binary values. Therefore, it has to show one of two stable states and can flip into the other one by an external interaction.

A good example of the usage of complex logic circuits can be seen in (part of) the [interactive circuit for the game pong](#). In this circuit are - besides a lot of known gates - also some components called "counter" and some with inputs named \$D\$, \$J\$, and \$K\$. But what are these? This shall be explained in the following sub-chapters.

## 5.1 Evolution of a Flip-Flop

A nice, short introduction can be found in the following video:



### 5.1.1 Flip-Flop as a Blackbox

To understand the wanted storage element, we will first look at these elements based on the IPO model (input-process-output).

The process of the storage element is to store two different states. This property can be implemented via two inverting gates which are interconnected in a feedback loop. The simple setup would be with NOT gates as shown in [figure 1](#).

Fig. 1: Storing two different states

Of course, these simple elements miss inputs and outputs! Therefore we have to look into these now.

The input of this element needs at least two inputs. Often the following two are used:

- Set input: once this input is high, a 1 is stored. This input is marked as S.
- Reset input: once this input is low, a 0 is stored. This input is marked as R.

For the output also often two pins are shown. The pin Q outputs the stored data directly. The pin /Q outputs the inverted value.

Based on these simple requirements we can create the truth table.

- When  $S=0$  and  $R=0$ , nothing changes and the outputs stay the same:  $Q(n+1)=Q(n)$ ,  $/Q(n+1)=/Q(n)$
- When  $S=1$  and  $R=0$ , the stored information will be set:  $Q(n+1)=1$ ,  $/Q(n+1)=0$
- When  $S=0$  and  $R=1$ , the stored information will be reset:  $Q(n+1)=0$ ,  $/Q(n+1)=1$
- When  $S=1$  and  $R=1$ , it is unclear what to do.



Fig. 2: truth table for the RS Flip-Flop

In figure 2 the last input ( $S=1$ ,  $R=1$ ) reaches a not defined state. This state has to be investigated later.

### 5.1.2 RS Flip-Flop - Open the Blackbox

First, the storage device has got some inputs to change the stored stage. For This, a “switchable” NOT-gate is needed. Looking back to the chapter [Boolean Algebra - Convertibility of Gates](#), this can be achieved by NAND gates or NOR gates.

In figure 3 a first approach is shown.

Fig. 3: storage device based on NAND or NOR

But how are the inputs  $X_0$  and  $X_1$  related to S and R, as well as the outputs Q and /Q to  $Y_0$  and  $Y_1$ ?

In this introduction, only flip-flops based on NOR gates are discussed - but flip-flops can also be built up with NAND gates. In figure 4 such a NOR flip-flop is shown. Compared to figure 3 the outputs had to be rearranged to have the pins sorted as shown in the logic symbol (see figure 5)

So let's analyze how this setup works! Therefore, the circuit in figure 4 has to be analyzed:

1. Initially,  $Q=0$  and the both inputs are 0. This is due to the following facts:

1. The upper NOR gate has also two \$0s as an input a outputs consequently  $Q=1$ .
2. This \$1 is also an input to the lower NOR gate.
3. This respectively generates  $Q=0$ . This situation is stable.
2. When setting  $S=1$  multiple things will happen successively:
  1. At first, the upper NOR gate has a \$1 on the input, which results into a \$0 at the output, and on  $Q$ .
  2. With  $Q=0$  also both inputs of the lower NOR gate are \$0.
  3. Therefore, the lower gate generates  $Q=1$ .
3. The stored data is also stable:
  1. This means  $Q=1$ , even when going back to the initial state  $S=0$  and  $R=0$ .
  2. The upper NOR gate still has one input set to \$1 and consequently still generates a \$0.
4. The only way to clear  $Q$  (i.e. to set  $Q=0$ ) is by setting  $R=1$ 
  1. This input the lower NOR gate has a \$1 as an input and outputs  $Q=0$ .
  2. By  $Q=0$  the inputs of the upper NOR gate also both get \$0.
  3. This results in  $Q=1$

The only problem (or better inconsistency) appears when setting both inputs to \$1:

- By this, both NOR gates generate \$0s
- This on the one hand creates  $Q=1$  and  $Q=1$ , which is not consistent.

This will get even more problematic:

- Both gates show typically not the same behavior concerning setting their outputs on a sub-microsecond scale to the voltage comparable with the logic \$1 or \$0.
- Therefore, once one will set the flip-flop back to the initial state  $S=0$  and  $R=0$  both NOR gates compete to set their output to \$1. The faster one will win.
- This results in arbitrary behavior.

Fig. 4: The RS Flip-Flop (based on NOR gates)



Fig. 5: The RS Flip-Flop xt is not SVG - cannot displ

### 5.1.3 D-Latch - Solving the Inconsistencies

To solve this undefined behavior one simple solution is to have the reset input  $R$  be always the negation of  $S$ <sup>1)</sup>. The input name is now changed to  $D$ , which refers to the stored data.

This single input solution is shown in [figure 6](#). The upper circuit in [figure 6](#) shows a common problem: when the circuit is not prepared correctly, the output could show an intermediate inconsistent situation. This can be seen for the switch from  $D=0$  to  $D=1$ . For a short time, the outputs are  $Q=Q-bar=0$ . A solution is to use a **buffer** (symbol "▷"). A buffer delays the signal for a similar timespan like a NOT-gate, but without negating the signal (shown in [figure 6](#) below).

Fig. 6: The RS Flip-Flop (based on NOR gates)

However, this circuit rises a “small problem”: now the state can be changed, but set and reset are based on one single input. Therefore, it is not a storage device, but more a kind of a delay: when the input data changes, the output changes after a constant short timespan, too.

In order to solve this next problem, another input  $E$  for enable is introduced (see figure 7). Only for  $E=1$  changes in the stored states are possible: For  $E=1$  the circuit gets **transparent**. Once  $E=0$ , no changes in the state can be done.

The given circuitry is also called **D-Latch** with the symbol shown in figure 8.

Generally, the term latch is used, when there is a transparent period. Otherwise, the circuit is called a flip-flop.

Fig. 7: The D Latch

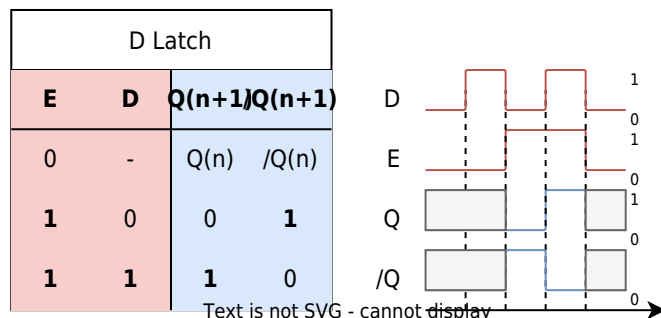

Fig. 8: Symbol and truth table of the D-Latch

### 5.1.4 Edge-Triggered D Flip-Flop - One at a time

In digital systems, the data processing is done clocked (i.e. once in a cycle). In the sub-chapter before, the input  $C$  was introduced. Once this input changes to  $C=0$ , the data could be used in the next logic stage.

Digital systems often need to be power efficient, to save energy and avoid overheating. A disadvantage of the D-latch is, that in the transparent phase, the signal can change often until it gets stored at the end of the phase. For every transition, a small additional current flow is needed. Therefore, the D-latch is not as power efficient, and would also pass on the transition to the next logic stages.

To change the full transparency into a single change per cycle, a circuit based on two D-latches in series can be used. In figure 9 the two latches can be seen in the upper part. The first latch is enabled with the negated **clock input**  $C$ . Therefore, the first latch is only transparent for  $C=0$ . The second latch gets the double negated clock input, which means, it is only transparent for  $C=1$ . The output is changed (and  $D$  is stored only for the switch from  $C=0$  to  $C=1$ . By this, the state of  $D$  is only stored, when switching  $C$ . When the switch from  $C=0$  to  $C=1$  is used, then this point in time is called **positive edge**.

The lower part in [figure 9](#) and [figure 10](#) shows the symbol of the D flip-flop.

Fig. 9: The Edge-Triggered D Flip-Flop



pos.edge triggered D Flip Flop			
C	D	Q(n+1)/Q(n+1)	
-	-	Q(n)	/Q(n)
↑	0	0	1
↑	1	1	0

Fig. 10: The D Flip-Flop

There are some important timing issues with all the flip-flops and latches, which will be discussed here. For this, the timing diagram of a positive edge triggered D flip-flop is shown in [figure 11](#). The upper line depicts the clock \$C\$, the middle line the data \$D\$, and the lower one the output \$Q\$.

1. The first positive edge, shows a delay between the triggering edge on \$C\$ and a resulting change in \$Q\$. This is called the **propagation delay time**  $t_{PD}$ . This delay reflects the time for the flip-flop to “process” the data.
2. At the second positive edge the data line \$D\$ is long enough low to switch the state of the flip-flop to \$0\$.
3. At the third edge, the **setup time**  $t_{su}$  and the **hold time**  $t_h$  is shown. When the change of the data input \$D\$ is not long enough the state of the flip-flop is likely not to be changed. The data on the third edge starts too late to be high. Therefore, the output \$Q\$ stays \$0\$.
4. On the last edge the data input is not long enough high to change the internal state of the flip-flop.

Fig. 11: timing of input, clock and output on a Flip-Flop

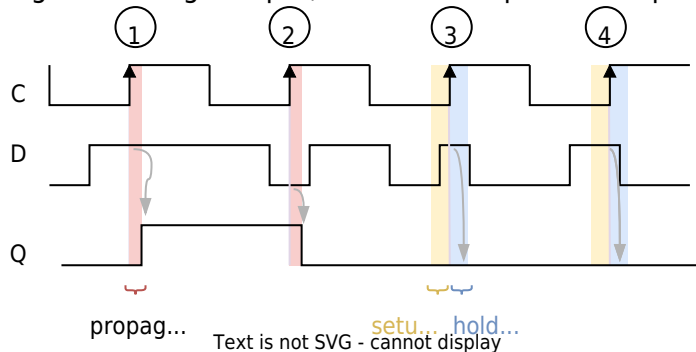

### 5.1.5 JK Flip-Flop - The Alternative to the undefined Behavior

The D flip-flop was generated based on a circuit with a series connection of two latches. Another idea could be to try a similar logic circuit based on two RS flip-flops. This can be seen in figure 12. It looks like a valid storage device: with  $R=1$  and  $S=0$  a rising edge clears the stored bit  $Q=0$ . Respectively, with  $R=0$  and  $S=1$  the stored bit is set and the output is  $Q=1$ . However,  $S=1$  and  $R=1$  still create an undefined behavior.

Fig. 12: First trial of a different edge triggered Flip-Flop

A nice tweak is to feedback on the outputs  $Q$  and  $\bar{Q}$  to the input AND-gate (see figure 13). This prohibits undefined behavior. In the beginning, the output  $Q$  and  $\bar{Q}$  are set correctly on the right-side RS flip-flop. Therefore, the feedback of  $Q$  and  $\bar{Q}$  only enables one AND-gate. With this start, the undefined states cannot be reached anymore. The input  $R=1$  and  $S=1$  create instead a toggling output for each edge on the clock  $C$ . This can also be seen in the truth table in figure 14.

Fig. 13: edge triggered JK Flip-Flop



pos. edge triggered JK Flip Flop				
C	J	K	Q(n+1)	Q(n+1)
-	-	-	Q(n)	/Q(n)
↑	0	0	Q(n)	/Q(n)
↑	0	1	0	1
↑	1	0	1	0
↑	1	1	/Q(n)	Q(n)

Fig. 14: Symbol and Truth Table of the edge triggered JK Flip-Flop

### 5.1.6 T Flip-Flop - changeable, when wanted

For the JK flip-flop, one input value toggles the output. This can also be used to create a new type of flipflop. For this, the  $J$  and  $K$  inputs are combined to a  $T$  (=toggle) input. This can also be seen in the truth table in figure 16.

Fig. 15: edge triggered T flip flop



pos.edge triggered T Flip Flop

C	T	Q(n+1)/Q(n+1)
-	-	Q(n) /Q(n)
↑	0	Q(n) /Q(n)
↑	1	/Q(n) Q(n)

Text is not SVG - cannot display

Fig. 16: Symbol and Truth Table of the edge triggered T flip flop

## 5.2 Convertibility of Flip-Flops

The previous chapter showed different flip-flops - but which are important to understand and remember? Mainly, these are:

- the asynchronous RS flip-flop as a base of all the other flip-flops and its use in ICs like the timer 555
- the edge triggered D flip-flop as a simple storage device of one bit.
- the edge triggered T flip-flop as one building block for counter and other sequential logic

Interestingly, the flip-flops can be converted into each other with the tools of the previous chapters. For this the following “recipe” will be used:

1. Look at the problem
2. Reduce it down to the relevant part
3. Build up a detailed truth table
4. Look at the relevant outputs
5. Fill in and use a Karnaugh map
6. Create the logic circuit

This strategy shall now be used to set up a JK flip-flop based on a D flip-flop.

### 5.2.1 Look onto the problem + Reduce it down to the relevant part

The first step is to take a deeper look at the problem: The idea is to emulate (or mimic) a JF flip-flop by the use of a D flip-flop and some logic circuit (see [figure 17](#)). So the main thing to find is the logic circuit.

Fig. 17: understanding the problem: JK flip-flop based on a D flip-flop



The truth tables of the two flip-flops are shown in figure 18. The relevant (and different) part here is for the rising edge. The other part is similar and does not need further investigation. Since the output  $/Q$  always has to be the negation of  $Q$ , it is only necessary to get the output  $Q$  right.

Fig. 18: understanding the problem: JK flip-flop based on a D flip-flop



pos. edge triggered JK Flip Flop				
C	J	K	$Q(n+1)$	$Q(n+1)$
-	-	-	$Q(n)$	$/Q(n)$
↑	0	0	$Q(n)$	$/Q(n)$
↑	0	1	0	1
↑	1	0	1	0
↑	1	1	$/Q(n)$	$Q(n)$

pos. edge triggered D Flip Flop				
C	D	$Q(n+1)$	$Q(n+1)$	
-	-	$Q(n)$	$/Q(n)$	
↑	0	0	1	
↑	1	1	0	

### 5.2.2 Build up a detailed truth table + look onto the relevant outputs

Now, a full truth table of the problem has to be filled. In the chapters before, only the external inputs were related to the output. In this case here, the output is also related to the former internal state. For example, the output of the JK flip-flop for  $J=K=0$  only depends on what the internal state was before.

So now we have to consider the inputs AND the internal states to get the output values.

In the figure 19 the truth table for the JK flip-flop is shown on the left side. Each second line is marked darker for better understanding. On the right site, a truth table is shown, which includes the relation to the internal state.

- For  $J=0$  and  $K=1$  the output have to be  $Q(n+1)=Q=0$  independent from the internal state
- For  $J=1$  and  $K=0$  the output have to be  $Q(n+1)=Q=1$  independent from the internal state

- For  $J=0$  and  $K=0$  the output will stay the same. Therefore  $Q(n+1)=Q(n)$
- For  $J=1$  and  $K=1$  the output will get inverted. Therefore  $Q(n+1)=\neg Q(n)$

Fig. 19: Creating the truth table for the JK flip-flop with  $Q(n+1)$  as an input

pos. edge triggered JK Flip Flop				
C	J	K	$Q(n)$	$Q(n+1)$
-	-	-	$Q(n)$	$\neg Q(n)$
↑	0	0	$Q(n)$	$\neg Q(n)$
↑	0	1	0	1
↑	1	0	1	0
↑	1	1	$\neg Q(n)$	$Q(n)$

Truth Table for Logic			
J	K	$Q(n)$	$Q(n+1)$
0	0	0	0
0	0	1	1
0	1	0	0
0	1	1	0
1	0	0	1
1	0	1	1
1	1	0	1
1	1	1	0

Text is not SVG - cannot display

When looking at this table, one has now to recap, what the main goal is: What does the combinatorial logic in front of the D flip-flop look like?

In figure 20 the circuitry of figure 17 is redrawn but now with the input and output variables of the wanted combinatorial logic. Based on the truth table of the flip-flop (figure 18) it is clear, that the D flip-flop simply delays the output for one cycle. Therefore, the input  $D$  for the D flip-flop is equal to  $Q(n+1)$  in figure 19

Fig. 20: understanding the problem: JK flip-flop based on a D flip-flop



### 5.2.3 Fill in and use a Karnaugh map + Create the logic circuit

Based on the truth table in figure 19 a Karnaugh map can be generated. This is shown in figure 21.

Fig. 21: Karnaugh Map for output D based on inputs J, K, and  $Q(n)$



The boolean formula for  $D$  is therefore:  $D = J \cdot \overline{Q(n)} + Q(n) \cdot \overline{K}$ .  
 With this, the logic circuit can be generated (see [figure 22](#)).

Fig. 22: Simulation of a JK Flip-Flop based on a D Flip-Flop

## 5.3 Applications of Flip-Flops

In the previous subchapter, a flip-flop was used to substitute a different flip-flop type. Well, that is nice, but what are the real applications of flip-flops?

To approach this question, first the differences between microcontrollers and microprocessors shall be discussed:

A **microprocessor** is mainly based on the central processing unit (CPU), which processes an incoming data flow. The CPU does this using:

- the **control unit** (CU), which decodes incoming commands.
- the **arithmetic logical unit** (ALU), which executes commands. Depending on the command sometimes loading and storing relevant data is also necessary.
- some registers. A register is a “specialized byte”, which has a major impact on controlling a program. One register is the program counter, which shows the current position (=address) in the program memory.

The program memory and further specialized logics are not part of the microprocessor.

A **microcontroller** is based on more parts:

- it contains the **CPU**, like the microprocessor. Often the CPU of the microprocessor is more lightweight, i.e. it takes less electrical power and is more efficient, but also has less processing power.
- **peripherals**: Peripherals are dedicated logic that reduced the workload of the CPU. One example is an up-counter, which can be started by the CPU and runs with a given step width to a given number. Once started the CPU no further processing by the CPU is needed. Further examples are:
  - **digital I/O** (digital input/output): To communicate with other ICs, the data to be transmitted has to be stored, to be sent/received bit by bit.
  - **analog I/O** (analog input/output): To analyze analog values an analog-digital-converter (ADC) digitalizes the analog values into binary numbers. The other direction is also possible with a digital-to-analog converter.
  - **interrupt controller**: Since the peripherals sometimes still need some interaction - e.g.

when the ADC just finished processing an analog value - a response is needed. Most of the peripherals use interrupts, which can abruptly stop the CPU to jump to a particular code for handling this situation. The interrupt controller is managing these breaks.

- **memory:** The code is commonly stored internally within the microcontroller IC. Often another storage for data is used within the IC. This memory stores the data permanently and is not based on flip-flops.

Nowadays, the microprocessors in computers and mobile devices evolved into “Systems on a Chip” (**SoC**) which more or less combines microprocessors and microcontrollers. So the still given differences in applications are that

- microprocessors are used for applications with complex human-machine interfaces like high-resolution graphical user interfaces (GUIs). They also consume more power, have a broad variety of complex commands, and often are based on multiple combined CPUs (“multicore”).
- microcontrollers are used for smaller, simpler applications. Here, the price, the low consumption, and/or the simple programming are important. Microcontrollers are used in dedicated applications, like controlling the ignition in combustion engine cars, or the motor speed of an electric toothbrush. In a mobile device often multiple microcontrollers are included.

But where are flip-flops used there? They are widely used in microcontrollers and microprocessors to

- store data,
- delay data,
- count up and down,
- multiply and divide by two, and more specifically double and half a frequency.

In combination with [combinatorial logic], even more, complex structures are possible: Virtually all possible outputs with or without an external trigger can be created. This will be looked at in detail in the following chapter [sequential logic](#).

Here, the above-mentioned simpler applications will be investigated.

### 5.3.1 Data Register

A data register can store data based on one or more bits for a distinct time within the microprocessor or microcontroller. Usually, the data is stored for multiple clock cycles.

The [figure 23](#) shows a 4-bit data register based on parallel D flip-flops. It can hold the data for one clock cycle. In the shown logic the flip-flops are clocked synchronously: they change their states at the same time based on the clock as a trigger. In the simulation, the inputs  $X0$ ... $X3$  can be changed by clicking on the binary numbers below the flip-flops.

To store the data for a longer time, an additional input (e.g. an ENable pin) could deactivate the clock input, when the data has to be stored.

Data registers are used to hold the input and output data of the CPU and peripherals.

#### Exercise 5.3.1.1 Data Register

Investigate the simulation in [figure 23](#) by toggling the inputs via click on the input value.

- Does the flip-flop act on a rising or falling edge?
- The given circuit can only store the data for a maximum of one step. An idea could be to implement another input  $EN$  as an enable pin.  
How is this to be connected with the other inputs ( $CLK$ ,  $X0$ ,  $X1$ ,  $X2$ ,  $X3$ ) to facilitate an enable pin?

Fig. 23: 4-Bit Register based on D Flip-Flops

### 5.3.2 Shift Register

Another register is the shift register. This moves stored data (e.g. a byte like  $a=86=0b0101\ 0110$ ) to the left ( $0b0010\ 1011=43$ ) or to the right ( $0b1010\ 1100=172$ ). This is used in the CPU to execute the shift C-commands like `unsigned int a=b>>2` or `unsigned int a=c<<3`. Additionally, it enables multiplying or dividing by 2 and is also used with the full adder in multiplication algorithms. Furthermore, a shift register can be used for a bit-by-bit output of an 8-bit (or larger) value in communication.

The [figure 24](#) shows a 4-bit shift register based on D flip-flops. In contrast to [figure 23](#) here the flip-flops are connected in serial. Therefore, the output of one flip-flop is the input of the next one and will be stored in the next clock cycle.

#### Exercise 5.3.2.1 Shift Register

1. Investigate the simulation in [figure 24](#) by toggling the input via click on the input values.
2. What happens when one deletes the input pin and connects the rightmost  $Q$  output to the input?

Fig. 24: 4Shift Register based on D Flip-Flops

One application for a shift register is a “short-term memory”: In [figure 25](#) the shift register stores the last 4 states of an incoming input bit stream. The logic circuit after the shift register compares the stored data with a given input  $X3\dots X0$ . Once the exact bit sequence is detected the output switches to  $Y=1$ .

Fig. 25: 4Shift Register in a Binary Sequence Detector

### 5.3.3 Frequency Divider

For some applications, only a fraction of the internal clock cycle is necessary. For example, external memory can usually only work with much slower frequencies compared to the CPU. To get a fraction of a given clock frequency a frequency divider can be used.

In [figure 26](#) a 4bit frequency divider based on 4 T flip-flops is shown. Each output of the previous flip-flop is the clock input for the next one. The leftmost flip-flop toggles its output for each rising edge from  $0$  to  $1$ . This expands the  $1$  state to the time between two rising edges, similarly with the  $0$  state. By this, the time between rising edges is doubled and the frequency is halved.

In contrast to the other two examples, here the flip-flops are clocked asynchronously, i.e. each flip-flop can only start its process when the previous flip-flop finished outputting its result  $Q$ . This adds up the delay given by the propagation delay time  $t_{PD}$  step by step. In the [figure 26](#) this can be seen when pushing the Reset button: the rising edge of all flip-flops are not at the same time, but delayed by multiples of  $0.5ns$ . For slower applications, this might be neglectable, but when multiple flip-flops are used asynchronously the delay will add up and can result in problematic retardation.

When looking at the decimal output in [figure 26](#) it seems, that it mostly represents a down-counter. But in detail, every second step down and even more every 4th step down (e.g. from 8 to 7) a glitch shows a wrong value shortly. This is due to the above-mentioned delay by the asynchronous flip-flops.

### Exercise 5.3.3.1 Frequency Divider

Investigate the simulation in [figure 26](#).

1. Have a look at what series the decimal number in the simulation proceeds.
2. Change the simulation in the following way:
  1. double click on  $CLK$  to edit the component and change the frequency to  $10\text{ MHz}$
  2. increase the simulation speed with the slider on the right side
  3. how does the series of the decimal output change? Does this solve the problem?

Fig. 26: Asynchronous Shift Register based on T Flip-Flops

The T flip-flop can be emulated with the D flip-flops, by the feedback of  $Q$  to the own input. So, for each next clock cycle, the negated value will be used and therefore the value will toggle. Since the flip-flops are still asynchronously driven (i.e. the clock input is still not triggered with a similar signal) the problems of these frequency dividers as a down-counter stills remain the same.

Fig. 26: Asynchronous Shift Register based on D Flip-Flops

### 5.3.4 Up-Counter

Counters have multiple applications. One nice application is to get non-binary base fractions from frequencies and more particularly: get a choosable fraction from a frequency.

To do so one has to combine the following components (see [figure 26](#)):

- an up-counter, which outputs an increasing binary number. This can additionally have a pin to reset the internal state asynchronously.
- a given maximum number in binary, here given by  $B$ .
- a comparator, which only outputs a  $1$  when the inputs  $A_0\dots A_3$  are bit by bit equal to  $B_0\dots B_3$ . The output of the comparator is set as an input of the up-counter.
- a toggle flip-flop that only toggles on the rising edge.

In [figure 26](#) also the decimal representation of  $A$  and  $B$  is shown to visualize the process and output. Additionally, also the input  $CLK$  and output  $Y$  are depicted in a timing diagram.

### Exercise 5.3.4.1 Up-Counter

Investigate the simulation in [figure 28](#).

How does the output  $Y$  change, when one changes the input pins given by  $B$ ?

Look for the  $Y$  in the timing diagram.

Fig. 28: Variable Frequency Divider

So the application is nice, but what does the counter internally look like? How can this counter be generated synchronously with flip-flops? For this, a 4bit up-counter based on T flip-flops shall be designed.

### Exercise 5.3.4.2 Designing an Up-Counter

The circuit in [figure 29](#) is a non-functioning up-counter. The circuit [figure 30](#) has a functioning up-counter as a black box.

Investigate the circuit in [figure 29](#):

- Does some of the outputs  $Y_n$  already show the correct result? Which one?
- We have now to focus on the outputs  $Y_n$  which show the wrong results. These have to be corrected. To do so a different input has to be chosen for these flip-flops. Start with the lowest incorrect output.
  - For which outputs of its previous flip-flops should it toggle its value?
  - How can this be implemented into a logic circuit?
- Try to implement the correct logic (only one basic gate is needed)!

Fig. 29: Up-Counter based on T Flip-Flops (not working)

Fig. 30: Up-Counter as Blackbox

## Examples

In a more functional version of a register is shown below.

It has

- the input pins  $X_7 \dots X_0$  (pins below the register)
- the output pins  $Y_7 \dots Y_0$  (pins on top of the register)
- a clock pin  $CLK$  to clock the circuit synchronously
- a pin called  $LOAD$  which resets the shifting to loading the internal flip flops with the bits given by the inputs. As long as  $LOAD=1$  no shifting is made
- a pin called  $DIR$  to set the direction.  $DIR=0$  leads to right shifting,  $DIR=1$  to left shifting.
- a pin called  $SIN$  for **S**erial **I**Nput. When right shifting  $Y_0$  will be set to  $SIN$ , when left shifting, then  $Y_7=SIN$
- the output pin  $SOUT$  for **S**erial **O**Utput

To see the register in action set (or reset)  $X7$ .... $X0$ ,  $DIR$ , and  $SIN$  and then stop the loading by resetting  $LOAD$  by  $LOAD=0$ .

The [figure 32](#) shows the interior of the register.

Fig. 31: Shift Register with synchronous Load, Direction Bit and Sout

Fig. 32: Interieur of a Shift Register with synchronous Load, Direction Bit and Sout

## Exercises

### Exercise 5.4.1.1 Flip Flops Timing Sequence

The [figure 33](#) shows a series of flip-flops and the  $RES$  pin set to 1.

Write down the sequence of the output  $Y0$ ... $Y3$  for each subsequent cycle of  $CLK$ , when  $RES=0$ .

Be aware, that on the flip-flops are input pins  $R$  (Reset) and  $S$  (Set). Once  $R=1$  the output of the flip-flop is set to  $Q=0$  independent of  $D$ . When  $R=0$ , the output of the flip-flop is set to  $Q=1$  independent of  $D$ .

Fig. 33: Exercise for Flip Flops Timing Sequence

Solution

---

## further Links

- [https://www.electronics-tutorials.ws/sequential/seq\\_1.html](https://www.electronics-tutorials.ws/sequential/seq_1.html)
- [https://www.electronics-tutorials.ws/counter/count\\_1.html](https://www.electronics-tutorials.ws/counter/count_1.html)

1)

Another easy way would be to have a **dominant** input, which overrules the other one when both inputs are \$1\$

From:  
<https://wiki.mexle.org/> - MEXLE Wiki

Permanent link:  
[https://wiki.mexle.org/introduction\\_to\\_digital\\_systems/storage\\_elements](https://wiki.mexle.org/introduction_to_digital_systems/storage_elements)

Last update: **2023/12/19 02:35**



