

# 1 Preparation, Properties, and Proportions

## Student Group

First Name	Surname	Matrikel Nr.

## Table of Contents

- 1. Preparation, Properties, and Proportions** ..... 4
- 1.1 Physical Proportions** ..... 4
- Learning Objectives ..... 4
- System of Units ..... 4
- derived quantities, SI units, and prefixes ..... 5
- Physical equations ..... 6
- Quantity equations ..... 7
- normalized quantity equations ..... 7
- Example for a quantity equation ..... 7
- Letters for physical quantities ..... 8
- Exercises ..... 9
- 1.2 Introduction to the Structure of Matter** ..... 9
- Learning Objectives ..... 9
- Elementary Charge ..... 9
- Conductivity ..... 10
- Conductor ..... 10
- Semiconductor ..... 10
- Isolator ..... 10
- Exercises ..... 10
- Exercise E13 Charges on a Ballon ..... 10
- Exercise E14 Charges on a Ballon ..... 11
- Exercise E15 Charges in Electroplating ..... 12
- Exercise E16 Charges in Electroplating ..... 12
- 1.3 Effects of electric charges and current** ..... 12
- Learning Objectives ..... 12
- First Approximation to the el. Charge ..... 13
- Coulomb-Force ..... 15
- Note! ..... 16
- 1.4 Charge and Current** ..... 16

Learning Objectives .....	16
Qualitative View .....	16
Definition of current .....	17
Note: .....	18
Direction of the Current .....	18
Definition of current direction (according to DIN5489) .....	19
Definition of electrodes (according to DIN5489) .....	19
Exercises .....	20
Exercise E17 Electron flow .....	20
Exercise E18 Determining the Current from Charge per Time .....	21
Exercise E19 Electron flow .....	22
Exercise E20 Determining the Current from Charge per Time .....	22
<b>1.5 Voltage, Potential, and Energy</b> .....	23
Learning Objectives .....	23
Energetic Approach .....	24
Comparison: Mechanics vs Electrics .....	25
Mechanical System .....	25
Electrical System .....	25
Note: .....	26
Definition of voltage .....	26
Voltage between two Points .....	26
Definition of the conventional direction of the voltage (according to DIN5489) .....	26
Exercises .....	26
Exercise 1.5.1 Direction of the voltage .....	26
<b>1.6 Resistance and Conductance</b> .....	27
Learning Objectives .....	27
Linearity of Resistors .....	29
Linear resistors .....	29
Non-linear resistors .....	29
Resistance as a material Property .....	30
Note: .....	31
Temperature Dependence of Resistors .....	31
Note: .....	33
Outlook .....	35
Types of temperature-dependent Resistors .....	35
NTC Thermistor .....	35
PTC Thermistor .....	35
Resistor Packages .....	36
Exercises .....	36
Exercise 1.6.1 Pre-calculated example of resistivity .....	37
Exercise 1.6.2 Resistance of a pencil stroke .....	37
Exercise 1.6.3 Resistance of a cylindrical coil .....	37
Exercise 1.6.4 Resistance of a supply line .....	37
Exercise 1.6.5 Strain gauges .....	38
Exercise 1.6.6: Temperature-dependent resistance of a winding (written test, approx. 6 % of a 60-minute written test, WS2020) .....	38
<b>1.7 Power and Efficiency</b> .....	39
Goal .....	39
Determining the electrical Power in a DC Circuit .....	39
Nominal Quantities of ohmic Loads .....	42
Efficiency .....	42

---

Exercises .....	43
Exercise 1.7.1 Pre-calculated example of electrical power and energy .....	43
Exercise 1.7.2 Power .....	44
Exercise 1.7.3 Power loss and efficiency I .....	44
Exercise 1.7.4 Power loss and efficiency II .....	44
Exercise 1.7.5 PPTC .....	45
<b>Further Reading</b> .....	47

# 1. Preparation, Properties, and Proportions

## 1.1 Physical Proportions

### Learning Objectives

By the end of this section, you will be able to:

1. know the fundamental physical quantities and the associated SI units.
2. know the most important prefixes. Be able to assign a power of ten to the respective abbreviation ( $\text{G}$ ,  $\text{M}$ ,  $\text{k}$ ,  $\text{d}$ ,  $\text{c}$ ,  $\text{m}$ ,  $\mu$ ,  $\text{n}$ ).
3. insert given numerical values and units into an existing quantity equation. From this, you should be able to calculate the correct result using a calculator.
4. assign the Greek letters.
5. always calculate with numerical value and unit.
6. know that a related quantity equation is dimensionless!

A nice 10-minute intro into some of the main topics of this chapter

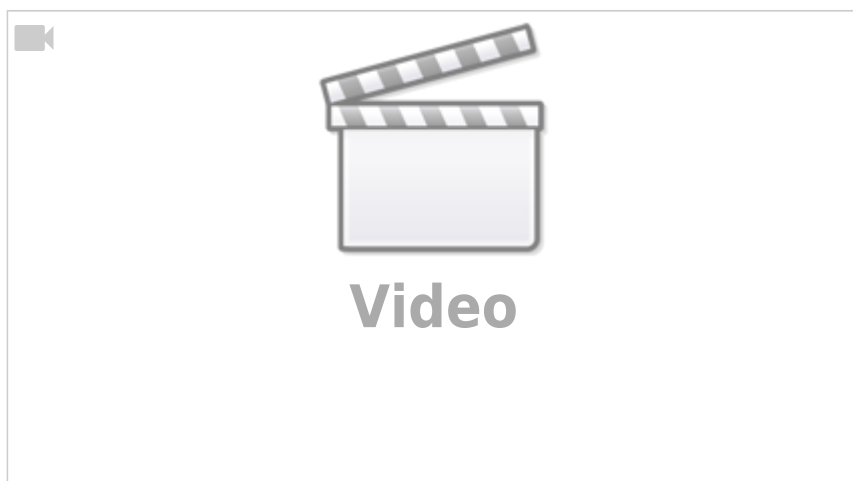

### System of Units

Short presentation of the SI units

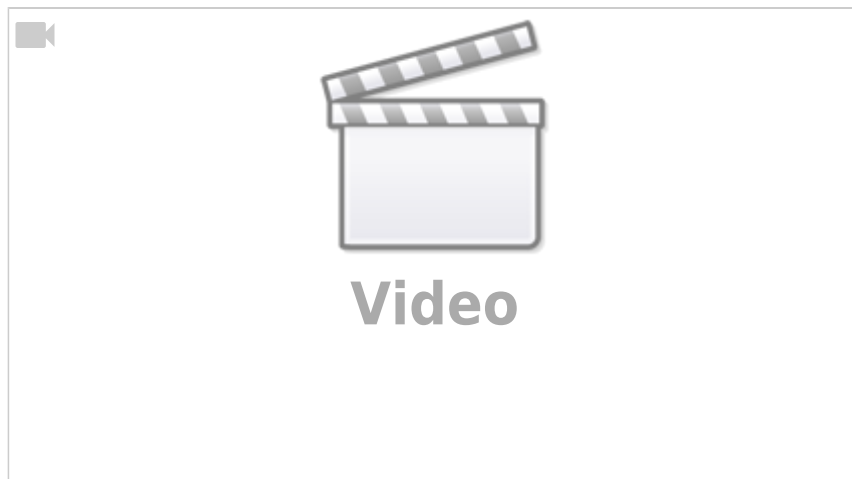

Base quantity	Name	Unit	Definition
Time	Second	$\{\rm s\}$	Oscillation of $\{\rm Cs\}$ -Atom
Length	Meter	$\{\rm m\}$	by $\{\rm s\}$ and speed of light
el. Current	Ampere	$\{\rm A\}$	by $\{\rm s\}$ and elementary charge
Mass	Kilogram	$\{\rm kg\}$	still by kg prototype
Temperature	Kelvin	$\{\rm K\}$	by triple point of water
amount of substance	Mol	$\{\rm mol\}$	via number of $\{^{12}\}\{\rm C\}$ nuclides
luminous intensity	Candela	$\{\rm cd\}$	via given radiant intensity

Tab. 1: SI-System

- For practical applications of physical laws of nature, **physical quantities** are put into mathematical relationships.
- There are basic quantities based on the SI system of units (French for *Système International d'Unités*), see below.
- In order to determine the basic quantities quantitatively (quantum = Latin for *how big*), **physical units** are defined, e.g.  $\{\rm metre\}$  for length.
- In electrical engineering, the first three basic quantities (cf. [table 1](#)) are particularly important. Mass is important for the representation of energy and power.
- Each physical quantity is indicated by a product of **numerical value** and **unit**:  
e.g.  $I = 2 \{\rm A\}$ 
  - This is the short form of  $I = 2 \cdot 1 \{\rm A\}$
  - $I$  is the physical quantity, here: electric current strength
  - $\{I\} = 2$  is the numerical value
  - $\{I\} = 1 \{\rm A\}$  is the (measurement) unit, here:  $\{\rm Ampere\}$

## derived quantities, SI units, and prefixes

- Besides the basic quantities, there are also quantities derived from them, e.g.  $1 \frac{\{\rm m\}}{\{\rm s\}}$ .
- SI units should be preferred for calculations. These can be derived from the basic quantities **without a numerical factor**.
  - The pressure unit bar ( $\{\rm bar\}$ ) is an SI unit.
  - BUT: The obsolete pressure unit "Standard atmosphere" ( $= 1.013 \{\rm bar\}$ ) is **not** an SI unit.
- To prevent the numerical value from becoming too large or too small, it is possible to replace a decimal factor with a prefix. These are listed in [table 2](#).

prefix	prefix symbol	meaning
Yotta	$\{\rm Y\}$	$10^{24}$
Zetta	$\{\rm Z\}$	$10^{21}$
Exa	$\{\rm E\}$	$10^{18}$
Peta	$\{\rm P\}$	$10^{15}$
Tera	$\{\rm T\}$	$10^{12}$
Giga	$\{\rm G\}$	$10^9$
Mega	$\{\rm M\}$	$10^6$
Kilo	$\{\rm k\}$	$10^3$
Hecto	$\{\rm h\}$	$10^2$
Deka	$\{\rm de\}$	$10^1$

Tab. 2: Prefixes I

prefix	prefix symbol	meaning
Deci	$\{\rm d\}$	$10^{-1}$
Centi	$\{\rm c\}$	$10^{-2}$
Milli	$\{\rm m\}$	$10^{-3}$
Micro	$\{\rm u\}$ , $\mu$	$10^{-6}$
Nano	$\{\rm n\}$	$10^{-9}$
Piko	$\{\rm p\}$	$10^{-12}$
Femto	$\{\rm f\}$	$10^{-15}$
Atto	$\{\rm a\}$	$10^{-18}$
Zeppto	$\{\rm z\}$	$10^{-21}$
Yocto	$\{\rm y\}$	$10^{-24}$

Tab. 2: Prefixes II

Importance of orders of magnitude in engineering (when the given examples in the video are unclear: we will get into this.)



## Physical equations

- Physical equations allow a connection of physical quantities.
- There are two types of physical equations to distinguish (at least in German):
  - Quantity equations (in German: *Größengleichungen*)
  - Normalized quantity equations (also called related quantity equations, in German *normierte Größengleichungen*)

## Quantity equations

The vast majority of physical equations result in a physical unit that does not equal \$1\$.

Example: Force  $F = m \cdot a$  with  $[F] = 1 \sim \text{kg} \cdot \frac{\text{m}}{\text{s}^2}$

- A unit check should always be performed for quantity equations
- Quantity equations should generally be preferred

## normalized quantity equations

In normalized quantity equations, the measured value or calculated value of a quantity equation is divided by a reference value. This results in a dimensionless quantity relative to the reference value.

Example: The efficiency  $\eta = \frac{P_{\text{O}}}{P_{\text{I}}}$  is given as quotient between the outgoing power  $P_{\text{O}}$  and the incoming power  $P_{\text{I}}$ .

As a reference the following values are often used:

- Nominal values (maximum permissible value in continuous operation) or
- Maximum values (maximum value achievable in the short term)

For normalized quantity equations, the units should **always** cancel out.

## Example for a quantity equation

Let a body with the mass  $m = 100 \sim \text{kg}$  be given. The body is lifted by the height  $s = 2 \sim \text{m}$ .

What is the value of the needed work?

physical equation:

Work = Force  $\cdot$  displacement

$W = F \cdot s \quad \quad \quad$ ; where  $F = m \cdot g$

$W = m \cdot g \cdot s \quad \quad \quad$  where  $m = 100 \sim \text{kg}$ ,  $s = 2 \sim \text{m}$  and  $g = 9.81 \sim \frac{\text{m}}{\text{s}^2}$

$W = 100 \sim \text{kg} \cdot 9.81 \sim \frac{\text{m}}{\text{s}^2} \cdot 2 \sim \text{m}$

$W = 100 \cdot 9.81 \cdot 2 \text{ ; ; } \text{kg} \cdot \frac{\text{m}}{\text{s}^2}$

```

\cdot {\rm m} $
$W = 1962 \quad\quad \cdot \quad\quad; \left( {\rm kg} \cdot \frac{{\rm m}}{\rm s}^2 \right) \cdot {\rm m} $
$W = 1962 \sim {\rm Nm} = 1962 \sim {\rm J} $
    
```

## Letters for physical quantities

In physics and electrical engineering, the letters for physical quantities are often close to the English term.

Thus explains  $C$  for **C**apacity,  $Q$  for **Q**uantity and  $\varepsilon_0$  for the **E**lectrical **F**ield **C**onstant. But, maybe you already know that  $C$  is used for the thermal capacity as well as for the electrical capacity. The Latin alphabet does not have enough letters to avoid conflicts for the scope of physics. For this reason, Greek letters are used for various physical quantities (see [table 4](#)).

Especially in electrical engineering, **upper/lower case letters** are used to distinguish between

- a constant (time-independent) quantity, e.g. the period  $T$
- or a time-dependent quantity, e.g. the instantaneous voltage  $u(t)$

Uppercase letters	Lowercase letters	Name	Application
$A$	$\alpha$	Alpha	angles, linear temperature coefficient
$B$	$\beta$	Beta	angles, quadratic temperature coefficient, current gain
$\Gamma$	$\gamma$	Gamma	
$\Delta$	$\delta$	Delta	small deviation, length of a air gap
$E$	$\epsilon$ , $\varepsilon$	Epsilon	electrical field constant, permittivity
$Z$	$\zeta$	Zeta	- (math function)
$H$	$\eta$	Eta	efficiency
$\Theta$	$\theta$ , $\vartheta$	Theta	temperature in Kelvin
$I$	$\iota$	Iota	-
$K$	$\kappa$	Kappa	specific conductivity
$\Lambda$	$\lambda$	Lambda	- (wavelength)
$M$	$\mu$	Mu	magnetic field constant, permeability
$N$	$\nu$	Nu	-
$\Xi$	$\xi$	Xi	-
$O$	$\omicron$	Omicron	-
$\Pi$	$\pi$	Pi	math. product operator, math. constant
$R$	$\rho$ , $\varrho$	Rho	specific resistivity
$\Sigma$	$\sigma$	Sigma	math. sum operator, alternatively for specific conductivity
$T$	$\tau$	Tau	time constant
$\Upsilon$	$\upsilon$	Upsilon	-
$\Phi$	$\phi$ , $\varphi$	Phi	magnetic flux, angle, potential
$\chi$	$\chi$	Chi	-

Uppercase letters	Lowercase letters	Name	Application
$\Psi$	$\psi$	Psi	linked magnetic flux
$\Omega$	$\omega$	Omega	unit of resistance, angular frequency

Tab. 4: greek letters

## Exercises

# 1.2 Introduction to the Structure of Matter

### Learning Objectives

By the end of this section, you will be able to:

1. know the size of the elementary charge

## Elementary Charge

Charge in Matter

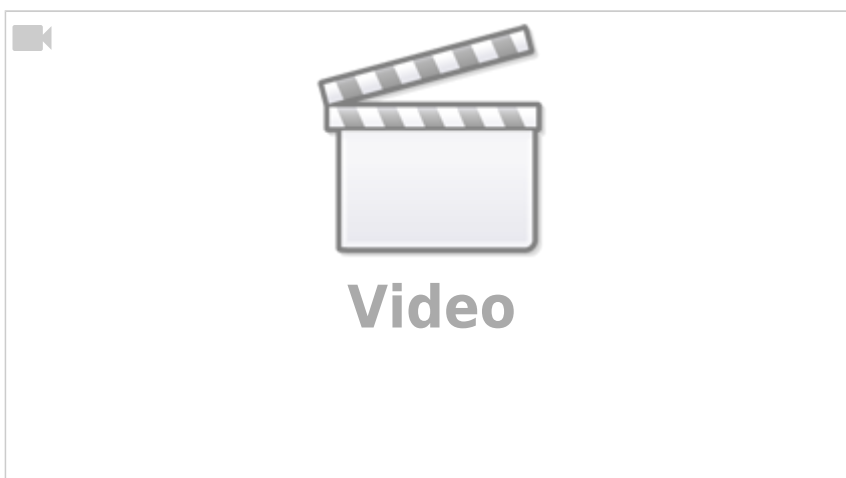

- Explanation of the charge based on the atomic models according to Bohr and Sommerfeld (see [figure 9](#))
- Atoms consist of
  - Atomic nucleus (with protons and neutrons)
  - Electron shell
- Electrons are carriers of the elementary charge  $|e|$
- elementary charge  $|e| = 1.6022 \cdot 10^{-19} \sim \text{C}$
- Proton is the antagonist, i.e. has the opposite charge
- Sign is arbitrarily chosen:
  - Electron charge:  $-e$
  - proton charge:  $+e$
- All charges on/in bodies can only occur as integer multiples of the elementary charge.
- Due to the small numerical value of  $e$ , the charge is considered as a continuum when viewed

macroscopically.

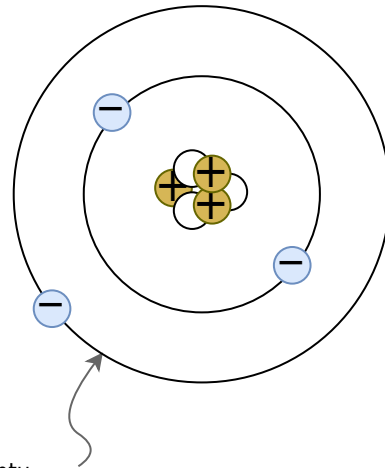

Fig. 9: Atomic model according to Bohr / Sommerfeld Text is not SVG - cannot display

## Conductivity

Conductor	Semiconductor	Isolator	Exercis es
<p>Charge carriers are freely movable in the conductor.</p> <p>Examples:</p> <ul style="list-style-type: none"> <li>• Metals</li> <li>• Plasma</li> </ul>	<p>In semiconductors, charge carriers can be generated by heat and light irradiation. Often a small movement of electrons is already possible at room temperature.</p> <p>Examples:</p> <ul style="list-style-type: none"> <li>• Silicon</li> <li>• Diamond</li> </ul>	<p>In the insulator, charge carriers are firmly bound to the atomic shells.</p> <p>Examples:</p> <ul style="list-style-type: none"> <li>• many plastics and salts</li> </ul>	<p><b>Exercise E13</b> <b>Charges on a Balloon</b></p> <p>A balloon has a net charge of <math>Q = 7 \times 10^{-13} \text{ C}</math>. How many additional electrons are on the balloon?</p> <p>Solution</p>

```

\begin{align*} Q &= \\ &= 7 \cdot 10^{-9} \text{ C} \\ &= 7 \cdot 10^{-9} \text{ C} \\ &= \frac{7 \cdot 10^{-9} \text{ C}}{1.6022 \cdot 10^{-19} \text{ C/electron}} \\ &= 43.7 \cdot 10^9 \text{ electrons} \end{align*}

```

### Exercise E14 Charges on a Ballon

A balloon has a charge of  $Q = 7 \text{ nC}$  on its surface.

**Result** How many additional electrons are on the balloon?

**Solution**

```

\begin{align*} 43.7 \cdot 10^9 \text{ electrons} \end{align*}

```

```

\begin{align*} Q &= 7 \text{ nC} = 7 \cdot 10^{-9} \text{ C} \\ n_{\text{e}} &= \frac{7 \cdot 10^{-9} \text{ C}}{1.6022 \cdot 10^{-19} \text{ C/electron}} \\ &= 43.7 \cdot 10^9 \text{ electrons} \end{align*}

```

### Exercise E15 Charges in Electroplating

To get a different metal coating onto a surface, often [Electroplating](#) is used. In this process, the surface is located in a liquid, which contains metal ions of the coating.

In the following, a copper coating (e.g. for corrosion resistance) shall be looked on. The charge of one copper ion is around  $1.6022 \cdot 10^{-19} \text{ C}$ , what is the charge on the surface if there are  $8 \cdot 10^{22}$  ions added?

$$12'818 \text{ C}$$

Solution

$$8 \cdot 10^{22} \cdot 1.6022 \cdot 10^{-19} \text{ C} = 12'817.6 \text{ C}$$

### Exercise E16 Charges in Electroplating

To get a different metal coating onto a surface, often [Electroplating](#) is used. In this process, the surface is located in a liquid, which contains metal ions of the coating.

In the following, a copper coating (e.g. for corrosion resistance) shall be looked on. The charge of one copper ion is around  $1.6022 \cdot 10^{-19} \text{ C}$ , what is the charge on the surface if there are  $8 \cdot 10^{22}$  ions added?

$$12'818 \text{ C}$$

Solution

$$8 \cdot 10^{22} \cdot 1.6022 \cdot 10^{-19} \text{ C} = 12'817.6 \text{ C}$$

## 1.3 Effects of electric charges and current

### Learning Objectives

By the end of this section, you will be able to:

1. Know that forces act between charges.
2. Know and be able to apply Coulomb's law.

- What effects of electric charges and current do you know?

## **First Approximation to the el. Charge**

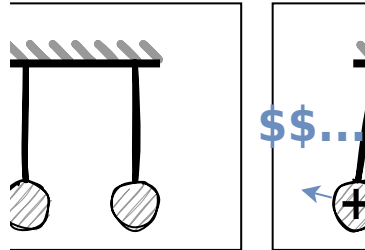

Fig. 10: Experiment 1 with two suspended charges

- first attempt (see [figure 10](#)):
  - Two charges ( $Q_1$  and  $Q_2$ ) are suspended at a distance of  $r$ .
  - Charges are generated by the high-voltage source and transferred to the two test specimens
- Result

- samples with same charges  $\rightarrow$  repulsion
- samples with charges of different sign  $\rightarrow$  attraction
- Findings
  - Forces cannot be explained mechanically
  - There seem to be two different types of charges.  $\rightarrow$  positive (+) and negative (-) charge

## Coulomb-Force

Setup for own experiments

Take a charge ( $+1 \sim \text{nC}$ ) and position it. Measure the field across a sample charge (a sensor).

Experiment with Coulomb's law and some calculated exercises

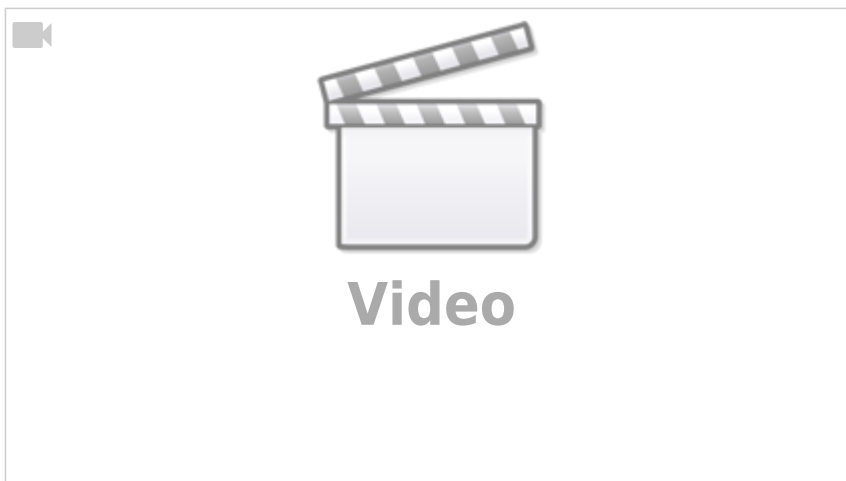

- Qualitative investigation using a second experiment
  - two charges ( $Q_1$  and  $Q_2$ ) at distance  $r$
  - additional measurement of the force  $F_C$  (e.g. via spring balance)
- Experiment results:
  - Force increases linearly with larger charge  $Q_1$  or  $Q_2$ .  
 $F_C \sim Q_1$  and  $F_C \sim Q_2$
  - Force falls quadratic with greater distance  $r$   
 $F_C \sim \frac{1}{r^2}$
  - with a proportionality factor  $a$ :  
 $F_C = a \cdot \frac{Q_1 \cdot Q_2}{r^2}$
- Proportionality factor  $a$
- The proportionality factor  $a$  is defined in such a way that simpler relations arise in electrostatics.
  - $a$  thus becomes:
  - $a = \frac{1}{4\pi \cdot \epsilon_0}$
  - $\epsilon_0$  is the **Coulomb constant** (also called electric field constant). In a vacuum,  
 $\epsilon_0 = \epsilon_0$ .
- The formula is similar to that of the gravitational force:  $F_G = \gamma \cdot \frac{m_1 \cdot m_2}{r^2}$

**Note!**

The Coulomb force (in a vacuum) can be calculated via.

$$\boxed{F_C = \frac{1}{4\pi\epsilon_0} \cdot \frac{Q_1 \cdot Q_2}{r^2}}$$

where  $\epsilon_0 = 8.85 \cdot 10^{-12} \cdot \frac{\text{C}^2}{\text{m}^2 \cdot \text{N}}$   
 $\epsilon_0 = 8.85 \cdot 10^{-12} \cdot \frac{\text{As}}{\text{Vm}}$

## 1.4 Charge and Current

### Learning Objectives

By the end of this section, you will be able to:

- distinguish the direction of conventional current and the flow of electrons.
- determine the cathode and anode of components
- apply the definition of current

What is Electric Charge and How Electricity Works

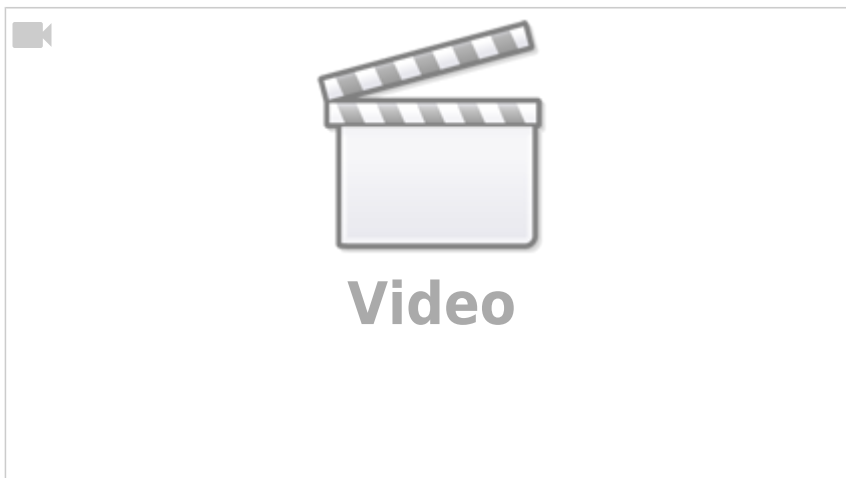

- From the previous experiments it is clear that there are two types of charge. In matter these are:
  - (+)  $\rightarrow$  excess of positive charges.
  - (-)  $\rightarrow$  excess of negative charges
- further experiment:
  - (+) and (-) are connected by a conductor
  - $\rightarrow$  electrons move from (-)-pole to (+)-pole
  - $\rightarrow$  electric current

### Qualitative View

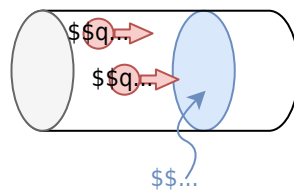

Fig. 11: Part of a Conductor

- In the thought experiment, let the following be given (see [figure 11](#)):
  - the above-mentioned conductor with a cross-section  $A$  perpendicular to the conductor
  - the quantity of charges  $\Delta Q = n \cdot e \cdot \Delta t$ , which in a certain period of time  $\Delta t$ , pass through the area  $A$
- In the case of a uniform charge transport over a longer period, i.e. direct current (DC), the following applies:
  - The amount of charges per time flowing through the surface is constant:
 
$$\frac{\Delta Q}{\Delta t} = \text{const.} = I$$
  - $I$  denotes the strength of the direct current.
  - The unit of  $I$  is the SI unit  $\text{Ampere}$ :  $1 \text{ A} = \frac{1 \text{ C}}{1 \text{ s}}$ . Thus, for the unit coulomb applies:  $1 \text{ C} = 1 \text{ A} \cdot 1 \text{ s}$

### Definition of current

The current of  $1 \text{ A}$  flows when an amount of charge of  $1 \text{ C}$  is transported in  $1 \text{ s}$  through the cross-section of the conductor.

Before 2019: The current of  $1\text{~}\{\text{A}\}$  flows when two parallel conductors, each  $1\text{~}\{\text{m}\}$  long and  $1\text{~}\{\text{m}\}$  apart, exert a force of  $F_C = 0.2 \cdot 10^{-6}\text{~}\{\text{N}\}$  on each other.

**Note:**

An electric current is the directed movement of free electric charge carriers.

## Direction of the Current

Fig. 12: Part of a conductor with different charged charges

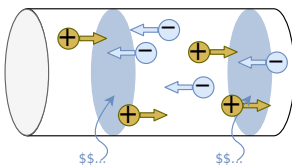

Charge transport can take place through (figure 12):

- negative charge carriers  $\Delta Q_n$  (e.g. electrons in a metallic conductor).
- positive charge carriers  $\Delta Q_p$  (e.g. certain semiconductor materials or in electrochemical cells)
- positive and negative charge carriers (e.g. certain semiconductor materials, plasma)

The total transported charge is  $\Delta Q = \Delta Q_p - \Delta Q_n$

$$Q_n = n_p \cdot e - n_n \cdot (-e)$$

→ The direction of current must be determined independently of the direction of motion of the electric charge carriers.

### Definition of current direction (according to DIN5489)

The current in a conductor from a cross-sectional area  $A_1$  to a cross-sectional area  $A_2$  is calculated positively, when:

- positive charge carriers move from  $A_1$  to  $A_2$ , resp
- negative charge carriers move from  $A_2$  to  $A_1$ .

The direction of the conventional current (or technical direction of current) is the direction of the positive current, i.e. the positive charge carriers.

### Definition of electrodes (according to DIN5489)

An electrode is a connection (or pin) of an electrical component.

As a rule, the dimension of an electrode is characterized by the fact that a change of material takes place (e.g. metal-→semiconductor, metal-→liquid).

The name of the electrode is given as follows:

- **Anode:** Electrode at which the current enters the component.
- **Cathode:** Electrode at which the current exits the component. (in German *Kathode*)

As a mnemonic, you can remember the structure, shape, and electrodes of the diode (see [figure 13](#)).

Fig. 13: Electrodes on the diode

---

## Exercises

### Exercise E17 Electron flow

How many electrons pass through a control cross-section of a metallic conductor when the current of  $40\text{ mA}$  flows for  $4.5\text{ s}$ ?

Solution

$$\begin{align*} 1.1 \cdot 10^{18} \end{align*} \text{ electrons}$$

$$\begin{aligned} Q &= I \cdot t \quad \&= 0.04 \text{~}\{\text{A}\} \cdot 4.5 \text{~}\{\text{s}\} \quad \&= 0.18 \text{~}\{\text{As}\} \\ &= 0.18 \text{~}\{\text{C}\} \quad \&= \{0.18 \text{~}\{\text{C}\}\} \cdot \{1 \over 1.6022 \cdot 10^{-19}\} \{\text{C/electron}\} \\ &= 1.1 \cdot 10^{18} \text{~}\{\text{electrons}\} \end{aligned}$$

### Exercise E18 Determining the Current from Charge per Time

Two objects are connected to a charge source, as per the changing the figure 14. One object shows non-linearly increasing in the charge per time.

#### Result

A non-linear charge increase leads to a non-constant current.  
 For a non-constant current, one has to use the time derivative of the charge  $Q$  to get the current  $I$ .  
 So, the formula  $I = \frac{dQ}{dt}$  has to be used instead of  $I = \frac{\Delta Q}{\Delta t}$ .

Fig. 14: Time course of the charge

1. Determine the currents  $I_1$  and  $I_2$  for the two objects from the  $Q$ - $t$ -diagram figure 14 and plot the currents into a new diagram.

#### Solution

- Have a look how much increase  $\Delta Q$  per time duration  $\Delta t$  is there for each object.
- For this choose a distinct time period, e.g. between  $0\text{~}\text{ms}$  and  $20\text{~}\text{ms}$ .
- The current is then given as the change in charge per time:  $I = \frac{\Delta Q}{\Delta t}$

### Exercise E19 Electron flow

How many electrons pass through a control cross-section of a metallic conductor when the current of  $40\text{~}\text{mA}$  flows for  $4.5\text{~}\text{s}$ ?

Solution

$$\begin{align*} & 1.1 \cdot 10^{18} \text{~}\text{electrons} \end{align*}$$

$$\begin{align*} Q &= I \cdot t \quad \&= 0.04\text{~}\text{A} \cdot 4.5\text{~}\text{s} \quad \&= 0.18\text{~}\text{As} \\ & \quad \&= 0.18\text{~}\text{C} \quad \&= \{0.18\text{~}\text{C}\} \cdot \left\{ \frac{1}{1.6022 \cdot 10^{-19}} \text{~}\text{C/electron} \right\} \\ & = 1.1 \cdot 10^{18} \text{~}\text{electrons} \end{align*}$$

### Exercise E20 Determining the Current from Charge per Time

Two objects experience a charge increase over time as shown in figure 10. How do the non-linear changes in the charge per time determine the current?

Result

A non-linear charge increase leads to a non-constant current. For a non-constant current, one has to use the time derivative of the charge  $Q$  to get the current  $I$ . So, the formula  $I = \frac{dQ}{dt}$  has to be used instead of  $I = \frac{\Delta Q}{\Delta t}$ .

Fig. 14: Time course of the charge ...

1. Determine the currents  $I_1$  and  $I_2$  for the two objects from the  $Q$ - $t$ -diagram [figure 14](#) and plot the currents into a new diagram.

Solution

- Have a look how much increase  $\Delta Q$  per time duration  $\Delta t$  is there for each object.
- For this choose a distinct time period, e.g. between  $0\text{ s}$  and  $20\text{ s}$ .
- The current is then given as the change in charge per time:  $I = \frac{\Delta Q}{\Delta t}$

## 1.5 Voltage, Potential, and Energy

### Learning Objectives

By the end of this section, you will be able to:

1. to determine the energy gain of a charge when overcoming a voltage difference.

## Energetic Approach

### Voltage vs Power vs Energy

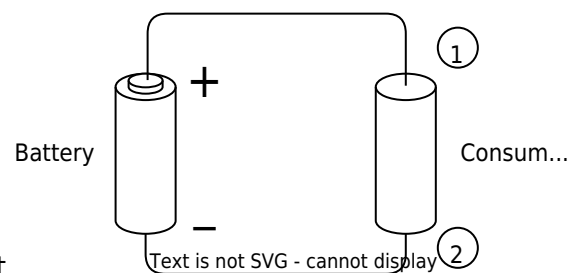
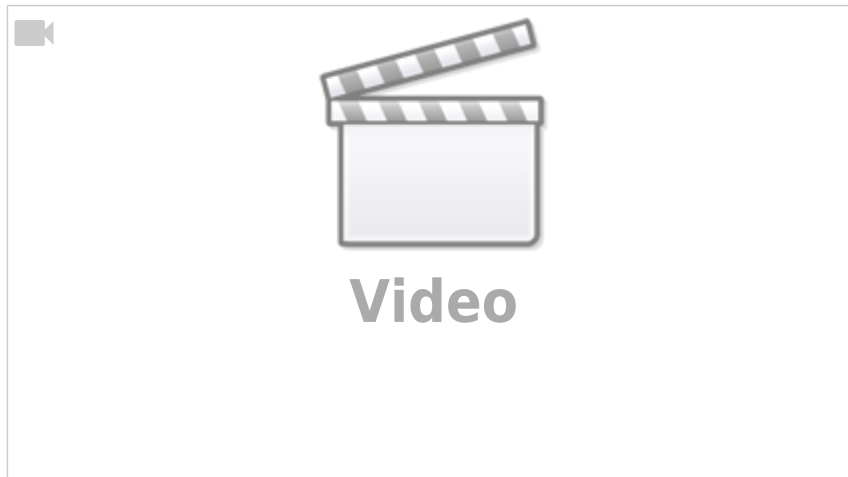

Fig. 16: Symbolic image of an electric circuit

Given is an electrical conductor (“consumer”) at a battery (see [figure 16](#))

- $\rightarrow$  Current flows
- Similar to the transport of a mass in the gravitational field, energy is needed to transport the charge in the “voltage field”
- We will look at the specific electric field in the next semester
- A point charge  $q$  is moved from electrode ① to electrode ②.  
The charge resembles a moving point of mass in the gravitational field.
- $\rightarrow$  there is a turnover of energy.
- The energy turnover is proportional to the amount of charge  $q$  transported.
- In many cases, the “energetic path” from ① to ② has to be characterized in charge-independent terms:  
$$\boxed{\frac{W_{1,2}}{q} = U_{1,2}}$$
- V for Voltage is in the English literature often used to denote the unit  $\{\text{V}\}$  AS WELL AS the quantity  $V$  (in German  $U$  is used for the quantity):
- e.g.
  - $V_{CC} = 5 \sim \{\text{V}\}$  : Voltage supply of an IC (Voltage Common Collector),
  - $V_{S+} = 15 \sim \{\text{V}\}$  : Voltage supply of an operational amplifier (Voltage Supply plus).

## Comparison: Mechanics vs Electrics

Fig. 17: Mechanical potential



### Mechanical System

#### Potential Energy

Potential energy is always related to a reference level (reference height). The energy required to move  $m$  from  $h_1$  to  $h_2$  is independent of the reference level.

$$\Delta W = W_1 - W_2 = m \cdot g \cdot (h_1 - h_2)$$

Fig. 18: Electrical Potential



### Electrical System

#### Potential

The potential  $\varphi$  is always specified relative to a reference point.

Common used are:

- Earth potential (ground, earth, ground).
- infinitely distant point

To shift the charge, the potential difference must be overcome. The potential difference is independent of the reference potential.  $\Delta W_{1,2} = W_1 - W_2 = Q \cdot \varphi_1 - Q \cdot \varphi_2 = Q \cdot (\varphi_1 - \varphi_2)$

Electric - Hydraulic Analogy: Charge, Voltage, and Current



V  
i  
d  
e  
o



It follows that:

$$\Delta W_{1,2} \over {Q} = \varphi_1 - \varphi_2 = U_{1,2}$$

**Note:**

- Voltage is always a potential difference.
- The unit of voltage is  $\text{V}$ :  $1 \sim \text{V}$

**Definition of voltage**

A voltage of  $1 \sim \text{V}$  is present between two points if a charge of  $1 \sim \text{C}$  undergoes an energy change of  $1 \sim \text{J} = 1 \sim \text{Nm}$  between these two points.

From  $W = U \cdot Q$  also the unit results:  $1 \sim \text{Nm} = 1 \sim \text{V} \cdot 1 \sim \text{As}$   
 $\rightarrow 1 \sim \text{V} = 1 \sim \frac{\text{Nm}}{\text{As}}$

**Voltage between two Points**

For the voltage between two points, using what we know so far, we get the following definition:

$$U_{12} = \varphi_1 - \varphi_2 = -U_{21} = -(\varphi_2 - \varphi_1)$$

Thus, the order of the indices must always be observed in the following.

**Definition of the conventional direction of the voltage (according to DIN5489)**

The voltage of  $U_{12}$  along a path from point ① to ② becomes positive when the potential in ① is greater than the potential in ②.

**Exercises****Exercise 1.5.1 Direction of the voltage**

Fig. 19: Example of conventional voltage specification

Explain whether the voltages  $U_{\text{Batt}}$ ,  $U_{12}$  and  $U_{21}$  in [figure 19](#) are positive or negative according to the voltage definition.

## 1.6 Resistance and Conductance

### Learning Objectives

By the end of this section, you will be able to:

- Know and be able to apply Ohm's law.
- calculate resistance from (specific) resistivity.
- determine the conductance from the resistance or the specific conductivity.

- know which cases of temperature dependence are distinguished and how they are named.
- calculate the resistance at different temperatures.
- know that there are different types of construction and that the physical value of the resistance does not depend on the geometric value.

Fig. 20: resistor as two-terminal component

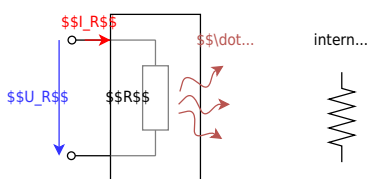

Current flow generally requires an energy input first. This energy is at some point extracted from the electric circuit and is usually converted into heat. The reason for this conversion is the resistance e.g. of the conductor or other loads.

A resistor is an electrical component with two connections (or terminals). Components with two terminals are called two-terminal networks or one-port networks (figure 20). Later in the semester, four-terminal networks will also be added.

In general, the cause-and-effect relationship is such that an applied voltage across the resistor produces the current flow. However, the reverse relationship also applies: as soon as an electric

current flows across a resistor, a voltage drop is produced over the resistor. In electrical engineering, circuit diagrams use idealized components in a [Lumped-element model](#). The resistance of the wires is either neglected - if it is very small compared to all other resistance values - or drawn as a separate "lumped" resistor.

The values of the resistors are standardized in such a way, that there is a fixed number of different values between  $1\ \Omega$  and  $10\ \Omega$  or between  $10\ \text{k}\Omega$  and  $100\ \text{k}\Omega$ . These ranges, which cover values up to the tenfold number, are called decades. In general, the resistors are ordered in the so-called [E series of preferred numbers](#), like 6 values in a decade, which is named E6 (here:  $1.0\ \text{k}\Omega$ ,  $1.5\ \text{k}\Omega$ ,  $2.2\ \text{k}\Omega$ ,  $3.3\ \text{k}\Omega$ ,  $4.7\ \text{k}\Omega$ ,  $6.8\ \text{k}\Omega$ ). As higher the number (e.g. E24) more different values are available in a decade, and as more precise the given value is.

For larger resistors with wires, the value is coded by four to six colored bands (see [conversion tool](#)). For smaller resistors without wires, often numbers are printed onto the components ([conversion tool](#))



Start drawing by  
clicking here

Fig. 21: examples for a real 15kOhm resistor

## Linearity of Resistors

### Linear resistors

Fig. 21: Linear resistors in the U-I diagram



- For linear resistors, the resistance value is  $R = \frac{U_R}{I_R} = \text{const.}$  and thus independent of  $U_R$ .
- **Ohm's law** results:  $R = \frac{U_R}{I_R}$  with unit  $[R] = \frac{[U_R]}{[I_R]} = 1 \frac{V}{A} = 1\ \Omega$
- In [figure 21](#) the value  $R$  can be read from the course of the straight line  $R = \frac{\Delta U_R}{\Delta I_R}$
- The reciprocal value (inverse) of the

### Non-linear resistors

Fig. 23: Non-linear resistors in the U-I diagram



- The point in the  $U$ - $I$  diagram in which a system rests is called the operating point. In the [figure 23](#) an operating point is marked with a circle in the left diagram.
- For nonlinear resistors, the resistance value is  $R = \frac{U_R}{I_R(U_R)} = f(U_R)$ . This resistance value depends on the operating point.
- Often small changes around the operating point are of interest (e.g. for small disturbances of load machines). For this purpose, the differential resistance  $r$  (also

resistance is called the conductance:  $G = \frac{1}{R}$  with unit  $1 \sim \text{S}$  ( $\text{Siemens}$ ). This value can be seen as a slope in the  $U$ - $I$  diagram.

dynamic resistance) is determined:  $r = \frac{dU_R}{dI_R} \approx \frac{\Delta U_R}{\Delta I_R}$  with unit  $[R] = 1 \sim \Omega$ .

- As with the resistor  $R$ , the reciprocal of the differential resistance  $r$  is the differential conductance  $g$ .
- In [figure 23](#) the differential conductance  $g$  can be read from the slope of the straight line at each point  $g = \frac{dI_R}{dU_R}$

### Resistance as a material Property

Clear explanation of resistivity

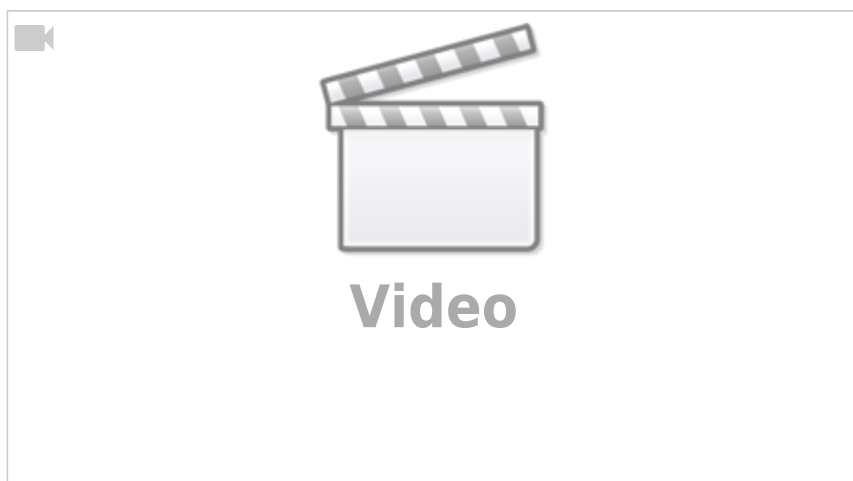

The value of the resistance can also be derived from the geometry of the resistor. For this purpose, an experiment can be carried out with resistors of different shapes. Thereby it can be stated:

- the resistance  $R$  increases proportionally with the distance  $l$  the current has to travel:  $R \sim l$
- the resistance  $R$  decreases inversely proportional with the cross-sectional area  $A$  through which the current passes:  $R \sim \frac{1}{A}$
- the resistance  $R$  depends on the material ([table 5](#))
- thus one obtains:  
 $R \sim \frac{l}{A}$

Material	$\rho$ in $\frac{\Omega \cdot \text{mm}^2}{\text{m}}$
Silver	$1.59 \cdot 10^{-2}$
Copper	$1.79 \cdot 10^{-2}$
Aluminium	$2.78 \cdot 10^{-2}$
Gold	$2.2 \cdot 10^{-2}$

Material	$\rho$ in $\frac{\Omega \cdot \text{mm}^2}{\text{m}}$
Lead	$2.1 \cdot 10^{-1}$
Graphite	$8 \cdot 10^0$
Battery Acid (Lead-acid Battery)	$1.5 \cdot 10^4$
Blood	$1.6 \cdot 10^6$
(Tap) Water	$2 \cdot 10^7$
Paper	$1 \cdot 10^{15} \dots 1 \cdot 10^{17}$

Tab. 5: Specific resistivity for different materials

**Note:**

The resistance can be calculated by

$$R = \rho \cdot \frac{l}{A}$$

- $\rho$  is the material dependent resistivity with the unit:  
 $[\rho] = \frac{[R] \cdot [A]}{l} = 1 \frac{\Omega \cdot \text{m}}{\text{m}^2} = 1 \frac{\Omega \cdot \text{m}}{\text{m}^2}$
- Often, instead of  $1 \frac{\Omega \cdot \text{m}}{\text{m}^2}$ , the unit  $1 \frac{\Omega \cdot \text{mm}^2}{\text{m}}$  is used. It holds that  $1 \frac{\Omega \cdot \text{mm}^2}{\text{m}} = 10^{-6} \frac{\Omega \cdot \text{m}}{\text{m}^2}$

- There exists also a specific conductance  $\kappa$ , given by the conductance  $G$  :  
 $G = \kappa \cdot \frac{A}{l}$
- The specific conductance  $\kappa$  is the reciprocal of the specific resistance  $\rho$ :  
 $\kappa = \frac{1}{\rho}$

## Temperature Dependence of Resistors

Explanation of the temperature dependence of resistors

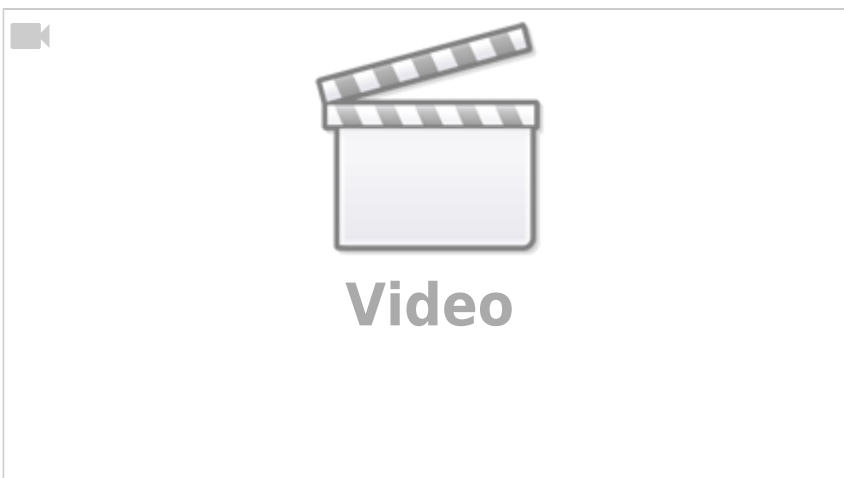

The resistance value is - apart from the influences of geometry and material mentioned so far - also influenced by other effects. These are e.g.:

- Heat (thermoresistive effect, e.g. in the resistance thermometer)

- Light (photosensitive effect, e.g. in the component photoresistor)
- Magnetic field (magnetoresistive effect, e.g. in hard disks)
- Pressure (piezoresistive effect e.g. tire pressure sensor)
- Chemical environment (chemoresistive effect e.g. chemical analysis of breathing air)

To summarize these influences in a formula, the mathematical tool of [Taylor series](#) is often used. This will be shown here practically for the thermoresistive effect. The thermoresistive effect, or the temperature dependence of the resistivity, is one of the most common influences in components.

The starting point for this is again an experiment. The ohmic resistance is to be determined as a function of temperature. For this purpose, the resistance is measured using a voltage source, a voltmeter (voltage measuring device), and an ammeter (current measuring device), and the temperature is changed ([figure 24](#)).

Fig. 24: Circuit for measuring the effect of temperature on a resistor

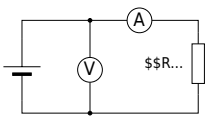

The result is a curve of the resistance  $R$  versus the temperature  $\vartheta$  as shown in [figure 25](#). As a first approximation is a linear progression around an operating point. This results in:

$$R(\vartheta) = R_0 + c \cdot (\vartheta - \vartheta_0)$$

- The constant is replaced by  $c = R_0 \cdot \alpha$
- $\alpha$  here is the linear temperature coefficient with unit:  $[\alpha] = \frac{1}{\vartheta} = \frac{1}{\text{K}}$
- Besides the linear term, it is also possible to increase the accuracy of the calculation of  $R(\vartheta)$  with higher exponents of the temperature influence. This approach will be discussed in more detail in the mathematics section below.
- These temperature coefficients are described with Greek letters:  $\alpha$ ,  $\beta$ ,  $\gamma$ , ...

Fig. 25: Influence of temperature on resistance

**Note:**

Fig. 26: Influence of temperature on resistance



The temperature dependence of the resistance is described by the following equation:

$$\boxed{R(\vartheta) = R_0 (1 + \alpha \cdot (\vartheta - \vartheta_0) + \beta \cdot (\vartheta - \vartheta_0)^2 + \gamma \cdot (\vartheta - \vartheta_0)^3 + \dots)}$$

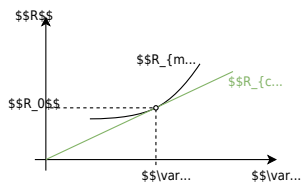
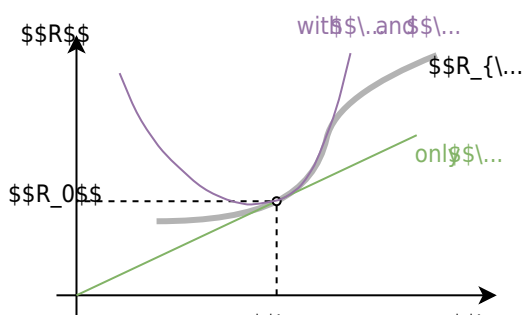
Where:

- $\alpha$  the (linear) temperature coefficient with unit:  $[\alpha] = \frac{1}{\text{K}}$
- $\beta$  the (quadratic) temperature coefficient with unit:  $[\beta] = \frac{1}{\text{K}^2}$
- $\gamma$  the temperature coefficient with unit:  $[\gamma] = \frac{1}{\text{K}^3}$
- $\vartheta_0$  is the given reference temperature, usually  $0^\circ\text{C}$  or  $25^\circ\text{C}$ .

The further the temperature range deviates from the reference temperature, the more temperature coefficients are required to reproduce the actual curve (figure 26).

### Outlook

In addition to the specification of the parameters  $\alpha, \beta, \dots$ , the specification of  $R_{25}$  and  $B_{25}$  can occasionally be found. This is a different variant of approximation, which refers to the temperature of  $25^\circ\text{C}$ . It is based on the [Arrhenius equation](#), which links reaction kinetics to temperature in chemistry. For the temperature dependence of the resistance, the Arrhenius equation links the inhibition of carrier motion by lattice vibrations to the temperature  $R(T) \sim e^{\frac{B}{T}}$ .

A series expansion can again be applied:  $R(T) \sim e^{A + \frac{B}{T} + \frac{C}{T^2} + \dots}$ .

However, often only  $B$  is given.

By taking the ratio of any temperature  $T$  and  $T_{25} = 298.15\text{K}$  ( $25^\circ\text{C}$ ) we get:  $\frac{R(T)}{R_{25}} = \frac{\exp\left(\frac{B}{T}\right)}{\exp\left(\frac{B}{298.15\text{K}}\right)}$  with  $R_{25} = R(T_{25})$

This allows the final formula to be determined:  $R(T) = R_{25} \cdot \exp\left(\frac{B_{25}}{T} - \frac{B_{25}}{298.15\text{K}}\right)$

## Types of temperature-dependent Resistors

Besides the temperature dependence as a negative, disturbing influence, some components have been deliberately developed for a specific temperature influence. These are called thermistors (a portmanteau of thermally sensitive resistor). Thermistors are divided into hot conductors and cold conductors.

A special form of thermistors is materials that have been explicitly optimized for minimum temperature dependence (e.g. Constantan or Isohm).

NTC Thermistor

PTC Thermistor

- As the name suggests, the NTC has a negative temperature coefficient. This leads to lower resistance at higher temperatures.
- Such an NTC thermistor is also called *Heißeleiter* in German (“hot conductor”).
- Examples are semiconductors
- Applications are inrush current limiters and temperature sensors. For the desired operating point, a strongly non-linear curve is selected there (e.g. fever thermometer).

Fig. 27: NTC thermistor in the U-I-diagram



- As the name suggests, the PTC has a positive temperature coefficient. This leads to lower resistance at lower temperatures.
- Such a PTC thermistor is also called *Kaltleiter* in German (“cold conductor”).
- Examples are doped semiconductors or metals.
- Applications are temperature sensors. For this purpose, they often offer a wide temperature range and good linearity (e.g. PT100 in the range of  $-100\text{~}^{\circ}\{\text{r m C}\}$  to  $200\text{~}^{\circ}\{\text{r m C}\}$ ).
- [Interactive example](#) for PTC thermistors

Fig. 28: PTC thermistor in the U-I diagram



## Resistor Packages

The packages are not explained in detail here. The video shows the smaller available packages. In the 3rd semester and higher we will use 0603-size resistors.

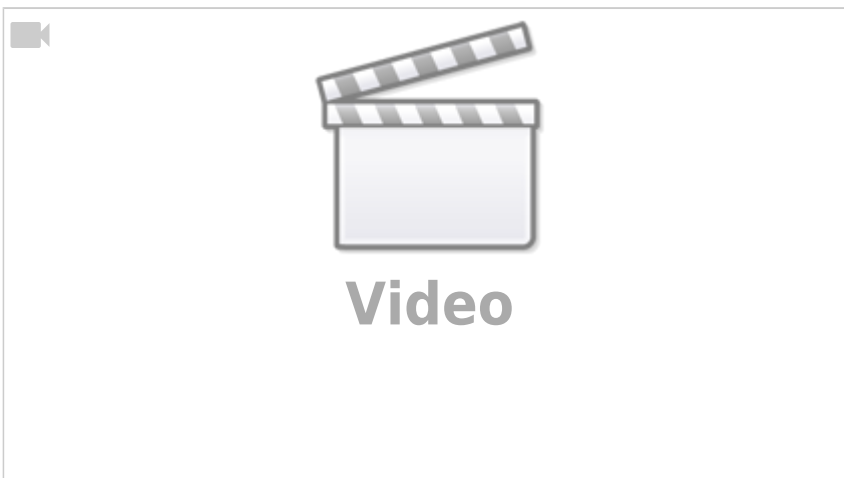

## Exercises

### Exercise 1.6.1 Pre-calculated example of resistivity

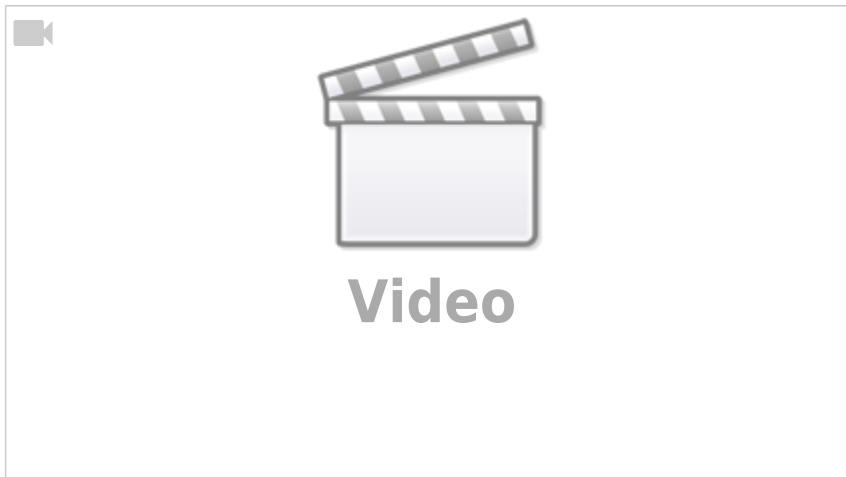

### Exercise 1.6.2 Resistance of a pencil stroke

Assume that a soft pencil lead is 100 % graphite. What is the resistance of a  $5.0\text{ cm}$  long and  $0.20\text{ mm}$  wide line if it has a height of  $0.20\text{ }\mu\text{m}$ ?

The resistivity is given by [table 5](#).

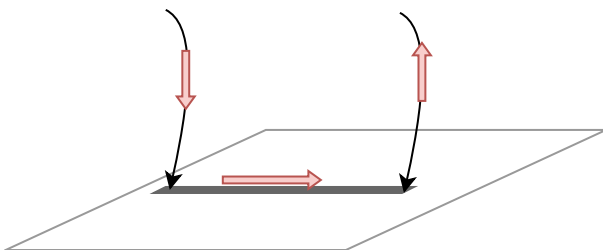

Final result

$$\begin{aligned} R = 10\text{ k}\Omega \end{aligned}$$

### Exercise 1.6.3 Resistance of a cylindrical coil

Let a cylindrical coil in the form of a multi-layer winding be given - this could for example occur in windings of a motor. The cylindrical coil has an inner diameter of  $d_i = 70\text{ mm}$  and an outer diameter of  $d_a = 120\text{ mm}$ . The number of turns is  $n_W = 1350$  turns, the wire diameter is  $d = 2.0\text{ mm}$  and the specific conductivity of the wire is  $\kappa_{\text{Cu}} = 56 \cdot 10^6 \frac{\text{S}}{\text{m}}$ .

First, calculate the wound wire length and then the ohmic resistance of the entire coil.

### Exercise 1.6.4 Resistance of a supply line

The power supply line to a consumer has to be replaced. Due to the application, the conductor resistance must remain the same.

- The old aluminium supply cable had a specific conductivity  $\kappa_{Al} = 33 \cdot 10^6 \frac{S}{m}$  and a cross-section  $A_{Al} = 115 \text{ mm}^2$ .
- The new copper supply cable has a specific conductivity  $\kappa_{Cu} = 56 \cdot 10^6 \frac{S}{m}$

Which wire cross-section  $A_{Cu}$  must be selected?

### Exercise 1.6.5 Strain gauges

t.b.d.

### Exercise 1.6.6: Temperature-dependent resistance of a winding (written test, approx. 6 % of a 60-minute written test, WS2020)

On the rotor of an asynchronous motor, the windings are designed in copper. The length of the winding wire is  $40 \text{ m}$ . The diameter is  $0.4 \text{ mm}$ . When the motor is started, it is uniformly cooled down to the ambient temperature of  $20^\circ \text{C}$ . During operation the windings on the rotor have a temperature of  $90^\circ \text{C}$ .

$$\alpha_{Cu, 20^\circ \text{C}} = 0.0039 \frac{1}{\text{K}}$$

$$\beta_{Cu, 20^\circ \text{C}} = 0.6 \cdot 10^{-6} \frac{1}{\text{K}^2}$$

$$\rho_{Cu, 20^\circ \text{C}} = 0.0178 \frac{\Omega \text{ mm}^2}{\text{m}}$$

Use both the linear and quadratic temperature coefficients! 1. determine the resistance of the wire for  $T = 20^\circ \text{C}$ .

Solution

$$\begin{aligned} R_{20^\circ \text{C}} &= \rho_{Cu, 20^\circ \text{C}} \cdot \frac{l}{A} \quad \text{with} \\ A &= r^2 \cdot \pi = \frac{1}{4} d^2 \cdot \pi \\ R_{20^\circ \text{C}} &= \rho_{Cu, 20^\circ \text{C}} \cdot \frac{4 \cdot l}{d^2 \cdot \pi} \\ &= 0.0178 \frac{\Omega \text{ mm}^2}{\text{m}} \cdot \frac{4 \cdot 40 \text{ m}}{(0.4 \text{ mm})^2 \cdot \pi} \end{aligned}$$

Final result

$$R_{20^\circ \text{C}} = 5.666 \Omega \rightarrow 5.7 \Omega$$

2. what is the increase in resistance  $\Delta R$  between  $20^\circ \text{C}$  and  $90^\circ \text{C}$  for one winding?

Solution

$$\begin{aligned} R_{90^\circ \text{C}} &= R_{20^\circ \text{C}} \cdot (1 + \alpha_{Cu, 20^\circ \text{C}} \cdot \Delta T + \beta_{Cu, 20^\circ \text{C}} \cdot \Delta T^2) \\ \Delta T &= T_2 - T_1 = 90^\circ \text{C} - 20^\circ \text{C} = 70^\circ \text{C} = 70 \text{ K} \\ \Delta R &= R_{20^\circ \text{C}} \cdot (\alpha_{Cu, 20^\circ \text{C}} \cdot \Delta T + \beta_{Cu, 20^\circ \text{C}} \cdot \Delta T^2) \\ &= 5.666 \Omega \cdot (0.0039 \frac{1}{\text{K}} \cdot 70 \text{ K} + 0.6 \cdot 10^{-6} \frac{1}{\text{K}^2} \cdot (70 \text{ K})^2) \end{aligned}$$

Final result

$$\Delta R \approx 1.56 \sim \Omega \rightarrow 1.6 \sim \Omega$$

## 1.7 Power and Efficiency

### Goal

After this lesson you should be able to:

1. Be able to calculate the electrical power and energy across a resistor.

A nice 10-minute intro into power and efficiency (a cutout from 2:40 to 12:15 from a full video of EEVblog)

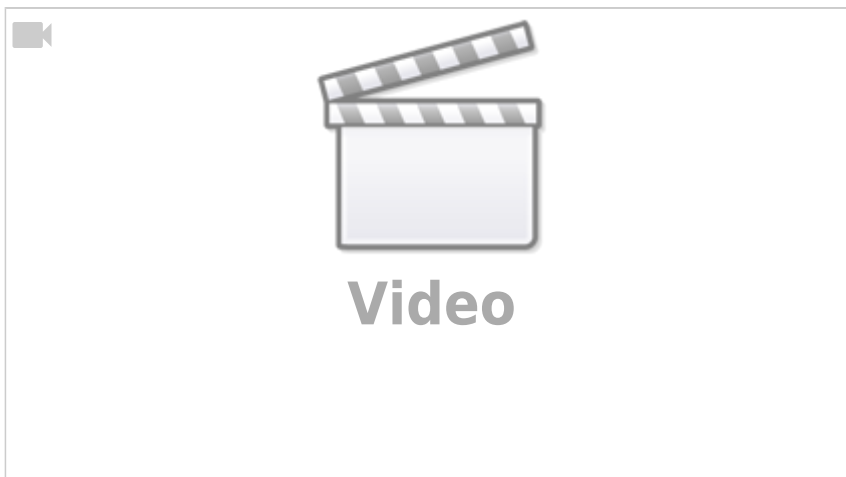

### Determining the electrical Power in a DC Circuit

From chapter [1.5 Voltage, potential, and energy](#) it is known that a movement of a charge across a potential difference corresponds to a change in energy. Charge transport therefore automatically means energy expenditure. Often, however, the energy expenditure per unit of time is of interest.

Fig. 29: Course of power and energy

SSBSWSS

Fig. 30: Source and consumer

The energy expenditure per time unit represents the **power**:

$\boxed{P = \frac{\Delta W}{\Delta t}}$  with the unit  $[P] = \frac{[W]}{[t]} = \frac{\text{J}}{\text{s}} = \frac{\text{Nm}}{\text{s}} = \text{N} \cdot \text{A} = \text{W}$

For a constant power  $P$  and an initial energy  $W(t=0) = 0$  holds:

$\boxed{W = P \cdot t}$

If the above restrictions do not apply, the generated/needed energy must be calculated via an integral.

Besides the current flow from the source to the consumer (and back), also power flows from the source to the consumer. In the following circuit, the color code shows the incoming and outgoing power.

If we only consider a DC circuit, the following energy is converted between the terminals (see also [figure 29](#) and [figure 30](#)):

$$W = U_{12} \cdot Q = U_{12} \cdot I \cdot t$$

This gives the power (i.e. energy converted per unit time):

$$P = U_{12} \cdot I$$

with the unit  $[P] = 1 \text{ V} \cdot 1 \text{ A} = 1 \text{ W}$  here stands for the physical unit watts.

For ohmic resistors:

$$P = R \cdot I^2 = \frac{U_{12}^2}{R}$$

### Nominal Quantities of ohmic Loads

Name of the nominal quantity	physical quantity	description
Nominal power (= rated power)	$P_{\text{N}}$	$P_{\text{N}}$ is the power output of a device (consumer or generator) that is permissible in continuous operation.
Nominal current (= rated current)	$I_{\text{N}}$	$I_{\text{N}}$ is the current occurring during operation at rated power.
Nominal voltage (= rated voltage)	$U_{\text{N}}$	$U_{\text{N}}$ is the voltage occurring during operation at rated power.

### Efficiency

The usable (= outgoing)  $P_{\text{O}}$  power of a real system is always smaller than the supplied (incoming) power  $P_{\text{I}}$ . This is due to the fact, that there are additional losses in reality. The difference is called power loss  $P_{\text{loss}}$ . It is thus valid:

$$P_{\text{I}} = P_{\text{O}} + P_{\text{loss}}$$

Instead of the power loss  $P_{\text{loss}}$ , the efficiency  $\eta$  is often given:

$$\eta = \frac{P_{\text{O}}}{P_{\text{I}}} < 1$$

For systems connected in series (cf. [figure 31](#)), the total resistance is given by:

$$\eta = \frac{P_{\text{O}}}{P_{\text{I}}} = \frac{P_{\text{O}_1}}{P_{\text{I}_1}} \cdot \frac{P_{\text{O}_2}}{P_{\text{I}_2}} \cdot \frac{P_{\text{O}_3}}{P_{\text{I}_3}} = \eta_1 \cdot \eta_2 \cdot \eta_3$$

Fig. 31: Power flow diagram

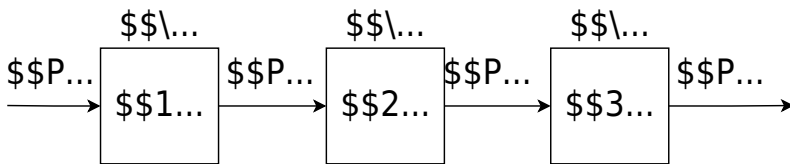

---

## Exercises

### Exercise 1.7.1 Pre-calculated example of electrical power and energy

The first 5:20 minutes is a recap of the fundamentals of calculating the electric power

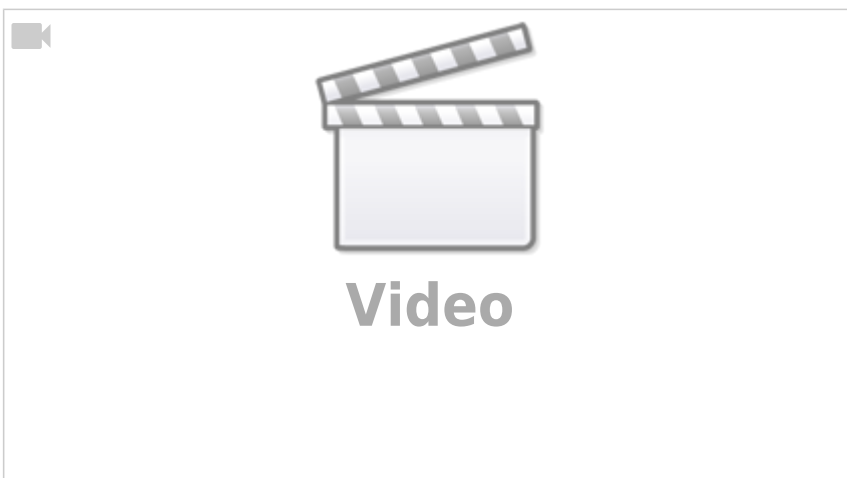

### Exercise 1.7.2 Power

An SMD resistor is used on a circuit board for current measurement. The resistance value should be  $R=0.2\ \Omega$ , and the maximum power  $P_M=250\ \text{mW}$ . What is the maximum current that can be measured?

### Exercise 1.7.3 Power loss and efficiency I

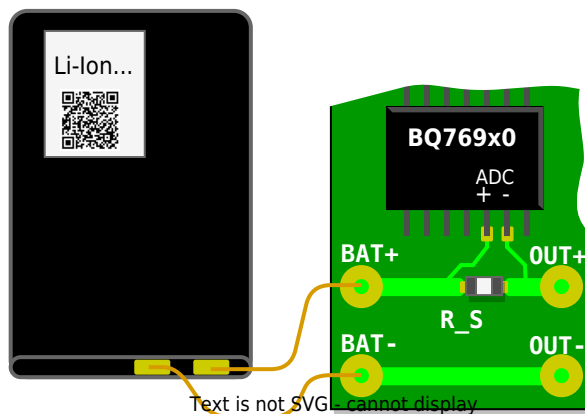

Fig. 32: Sketch of the setup

- The battery monitor BQ769x0 measures the charge and discharge currents of a lithium-ion battery using the voltage across a measuring resistor (shunt). In figure 32 the analog-to-digital converter ( $\text{ADC}$ ) of this chip is connected to the shunt  $R_S$  via the circuit board. Through the shunt, the discharge current flows from the battery connection  $\text{BAT+}$  to  $\text{OUT+}$  and via  $\text{OUT-}$  back to  $\text{BAT-}$ . The shunt shall be designed so that the bipolar measurement signals have a voltage level in the range of  $-0.20\ \text{V}$  to  $+0.20\ \text{V}$ . The analog-to-digital converter has a resolution of  $15\ \mu\text{V}$ . The currents can be used to count the charge in the battery to determine the state of charge ( $\text{SOC}$ ).
- Draw an equivalent circuit with a voltage source (battery), measuring resistor and load resistor  $R_L$ . Also, draw the measurement voltage and load voltage.
- The shunt should have a resistance value of  $1\ \text{m}\Omega$ . What maximum charge/discharge currents are still measurable? What minimum current change is measurable?
- What power loss is generated at the shunt in the extreme case?
- Now the efficiency is to be calculated
  - Find the efficiency as a function of  $R_S$  and  $R_L$ . Note that the same current flows through both resistors.
  - Special task: The battery is to have a nominal voltage of  $10\ \text{V}$  (3 cells) and the maximum discharge current is to flow. What efficiency results from the measurement alone?

### Exercise 1.7.4 Power loss and efficiency II

A water pump ( $\eta_P = 60\%$ ) has an electric motor drive ( $\eta_M = 90\%$ ). The pump has to pump  $500\ \text{l}$  water per minute up to  $12\ \text{m}$  difference in height.

- What must be the rated power of the motor?
- What current does the motor draw from the  $230\text{~V}$  mains? (assumption: the  $230\text{~V}$  is a DC value and also the current is DC)

### Exercise 1.7.5 PPTC

Often, parts of a circuit have to be protected from over-current, since otherwise, components could break. This is usually done by a fuse or a circuit breaker, which opens up the connection and therefore disables the path for the current. A problem with the commonly used fuses is, that once the fuse is blown (=it has been tripped) it has to be changed.

Since opening up electronics and changing the fuse is not reasonable for consumer electronics, these products nowadays use [resettable fuses](#). These consist of a polymer (=“plastics”) with conducting paths of graphite or carbon black in it. When more and more current is flowing, more and more heat is generated. At one distinct temperature, the polymer expands rapidly - which is also called phase change. This expansion moves the conducting paths apart. The system will stay in a state, where a minimum current is flowing, which maintains just enough heat dissipation for the expansion. This process is also reversible: When cooled down, the conducting paths get re-connected. These components are also called **polymer positive temperature coefficient** components or PPTC.

In the diagram below the internal structure and the resistance over the temperature are shown (more details about the structure and function can be found [here](#)).

\$...↑



In the given circuit below, a fuse  $F$  shall protect another component shown as  $R_L$ , which could be a motor or motor driver for example. In general, the fuse  $F$  can be seen as a (temperature variable) resistance. The source voltage  $U_S$  is  $50\text{ V}$  and  $R_L=250\text{ }\Omega$ .

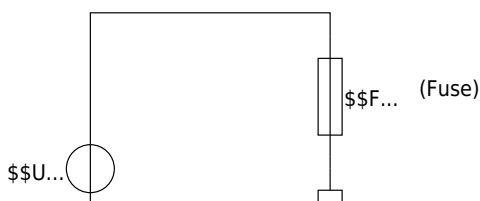

For this fuse, the component “[OZCG0020AF2C](#)”<sup>1)</sup> is used. When this fuse trips, it has to carry nearly the full source voltage and dissipates a power of  $0.8 \text{ W}$ .

- First assume that the fuse is not blown. The resistance of the fuse at this is  $1 \text{ }\Omega$ , which is negligible compared to  $R_L$ . What is the value of the current flowing through  $R_L$ ?
- Assuming for the next questions that the fuse has to carry the full source voltage and the given power is dissipated.
  - Which value will the resistance of the fuse have?
  - What is the current flowing through the fuse, when it is tripped?
  - Compare this resistance of the fuse with  $R_L$ . Is the assumption, that all of the voltage drops on the fuse feasible?

## Further Reading

1. [Omega Tau Nr. 303](#): German Podcast with a researcher from the BTP ([Physikalisch-Technische Bundesanstalt](#), Germany's national standardization institute) on the evolution of the SI unit system.
2. [How electric flow really works](#): No, there are no free electrons in the wire, and the electrons are not colliding with the atoms or atomic cores...

1)

the datasheet is not needed for this exercise

From:

<https://wiki.mexle.org/> - **MEXLE Wiki**

Permanent link:

[https://wiki.mexle.org/ee1/preparation\\_properties\\_proportions?rev=1696355080](https://wiki.mexle.org/ee1/preparation_properties_proportions?rev=1696355080)

Last update: **2023/10/03 19:44**

