

aufgabe_4.5.2_mit_rechnung

Student Group

First Name	Surname	Matrikel Nr.

Table of Contents

Aufgabe 4.5.2: Leerlaufspannung über Superposition (Klausuraufgabe, ca 12% einer 60minütigen Klausur, WS2020)	2
---	---

Aufgabe 4.5.2: Leerlaufspannung über Superposition (Klausuraufgabe, ca 12% einer 60minütigen Klausur, WS2020)



A circuit is given with the following parameters

$$R_1 = 5 \, \Omega$$

$$U_1 = 2 \, \text{V}$$

$$I_2 = 1 \, \text{A}$$

$$R_3 = 20 \, \Omega$$

$$U_3 = 8 \, \text{V}$$

$$R_4 = 10 \, \Omega$$

Determine the open circuit voltage between A and B using the principle of superposition.

Tips

- What do the individual circuits look like, by which the effects of the individual sources can be calculated?
Which equivalent resistor must be used to replace a current or voltage source when calculating the individual effects?
- Where are the open-circuit voltages applied when looking at the individual components?

Solution

First, the individual circuits must be created, from which the effect of the individual sources between points A and B can be determined.

(Voltage) source U_1

- substitute the current source I_2 with a short-circuit
- substitute the voltage source U_3 with an open circuit

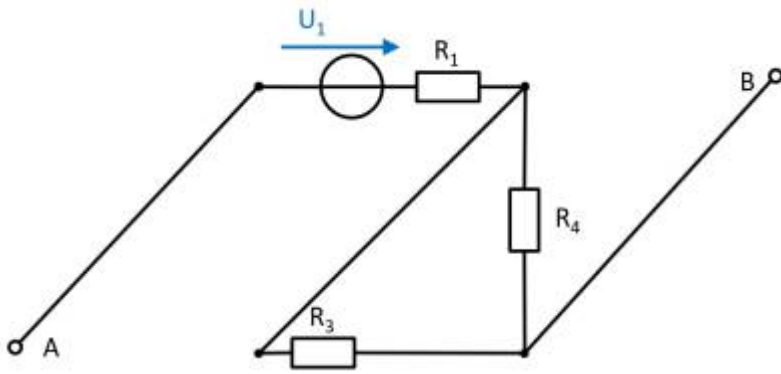

The components can be moved in order to understand the circuit s bit better.

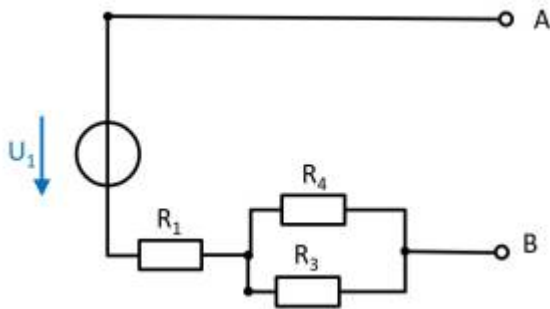

For the open circuit, no current is flowing through any resistor. Therefore, the effect is:
 $U_{AB,1} = U_1$

(current) source I_2

- substitute the voltage source U_1 with an open circuit
- substitute the voltage source U_3 with an open circuit

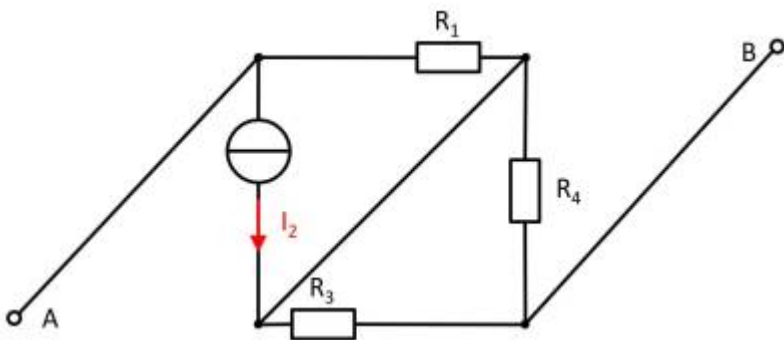

Also here, the components can be shifted for a better understanding:



Here, the current source I_2 creates a voltage drop $U_{AB,2}$ on the resistor R_2 :
 $U_{AB,2} = - R_1 \cdot I_2$

(Voltage) source U_3

- substitute the voltage source U_1 with an open circuit
- substitute the current source I_2 with a short-circuit

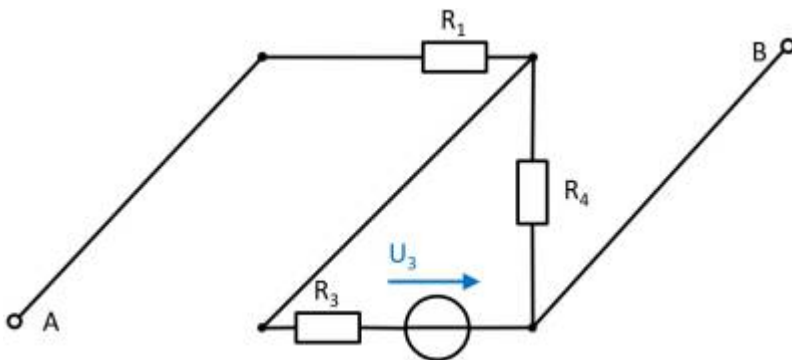

Again, rearranging the circuit might help for an understanding:



In this case, between the unloaded outputs A and B there will be an unloaded voltage divider given by R_3 and R_4 . On R_1 there is no voltage drop since there is no current flow out of the unloaded outputs.

Therefore:

$$U_{AB,3} = \frac{R_4}{R_3 + R_4} \cdot U_3$$

resulting voltage

$$\begin{aligned} U_{\text{AB}} &= U_1 - R_1 I_2 + \frac{R_4}{R_3 + R_4} U_3 \\ \end{aligned}$$

Final value

$$\begin{aligned} U_{\text{AB}} &= 2 \text{ V} - 5 \Omega \cdot 1 \text{ A} + \frac{10}{20 \Omega + 10 \Omega} \cdot 8 \text{ V} \\ U_{\text{AB}} &= 0.333 \text{ V} \end{aligned}$$

From:

<https://wiki.mexle.org/> - MEXLE Wiki

Permanent link:

https://wiki.mexle.org/electrical_engineering_1/aufgabe_4.5.2_mit_rechnung?rev=1679577262

Last update: **2023/03/23 14:14**

