

4 Analysis of Networks

Student Group

First Name	Surname	Matrikel Nr.

Table of Contents

- 4. Analysis of direct current networks** 2
 - Goals 2
 - 4.1 Preliminary work on network analysis** 2
 - Preparation of the circuit 2
 - Graph and Trees 3
 - 4.2 Branch Current Procedure** 5
 - Example of nodal equations 6
 - Example of loop equations 6
 - Another examples in videos 7
 - Exercise 4.2.1 8
 - Exercise 4.2.2 8
 - 4.3 mesh current method** 8
 - 4.4 Nodal potential method** 9
 - 4.5 Superposition method / Superposition principle** 10
 - Example 1 - from consulting industry interviews 10
 - Example 2 - Spring Force and Travel 11
 - Notice: 11
 - Example 12
 - Exercise 4.5.1 Converting a bipolar signal to a unipolar signal 13
 - Exercise 4.5.3 -Variation: open circuit voltage via superposition (exam task, approx. 12 % of a 60-minute exam, WS2020) 14
 - Exercise 4.5.4 - Variation: open circuit voltage via superposition (exam task, approx. 12 % of a 60-minute exam, WS2020) 16

4. Analysis of direct current networks

Fig. 1: examples for networks



Network analysis plays a central role in electrical engineering. It is so important because it can be used to simplify what at first sight appear to be complicated circuits and systems to such an extent that they can be understood and results derived from them.

In addition, networks also occur in other areas, for example the force flow through a truss or the heat flow through individual hardware elements (figure 1). The concepts shown below can also be applied to these networks.

On the [wiki page for network analysis](#) the different methods are described very well in a compact way

Goals

After this lesson, you should:

1. be able to determine the number of nodes, number of (tree and connecting) branches, and number of meshes.
2. be able to construct a complete tree from an electrical network.
3. be able to understand the branch current method, mesh current method, and node potential method.
4. Understand and be able to apply the superposition procedure.

4.1 Preliminary work on network analysis

Preparation of the circuit



Fig. 2: Preparing the circuit

Before the network analysis can be tackled, the circuit must be suitably prepared (cf. [figure 2](#)):

1. Clarify what is given and what is sought
2. Draw a circuit
3. Add counting arrows. If not already given, then:
 1. First draw current and voltage arrows at all sources according to the generator arrow system.
 2. Afterwards define the current arrows at the remaining branches as you like.
 3. Finally, draw the voltage arrows at the loads according to the load arrow system.
4. Select suitable current and voltage designations. If not already given, then:
 1. Count indices continuously, i.e. one number per element (source or load).
 2. Do not insert any signs in front of the designators in the circuit.

In real applications it is useful to specify the number of variables ("what is wanted?"), parameters ("what can be adjusted?", e.g. potentiometer) and known quantities ("what is given?"). This makes it clear how many equations are needed. This seems to become difficult for larger networks - but a trick for this is presented below.

It often helps to draw the drawing several times (at least in your head) to have enough space for the identifiers (cf. [figure 2](#) below).

Graph and Trees

Fig. 3: Graph of a network

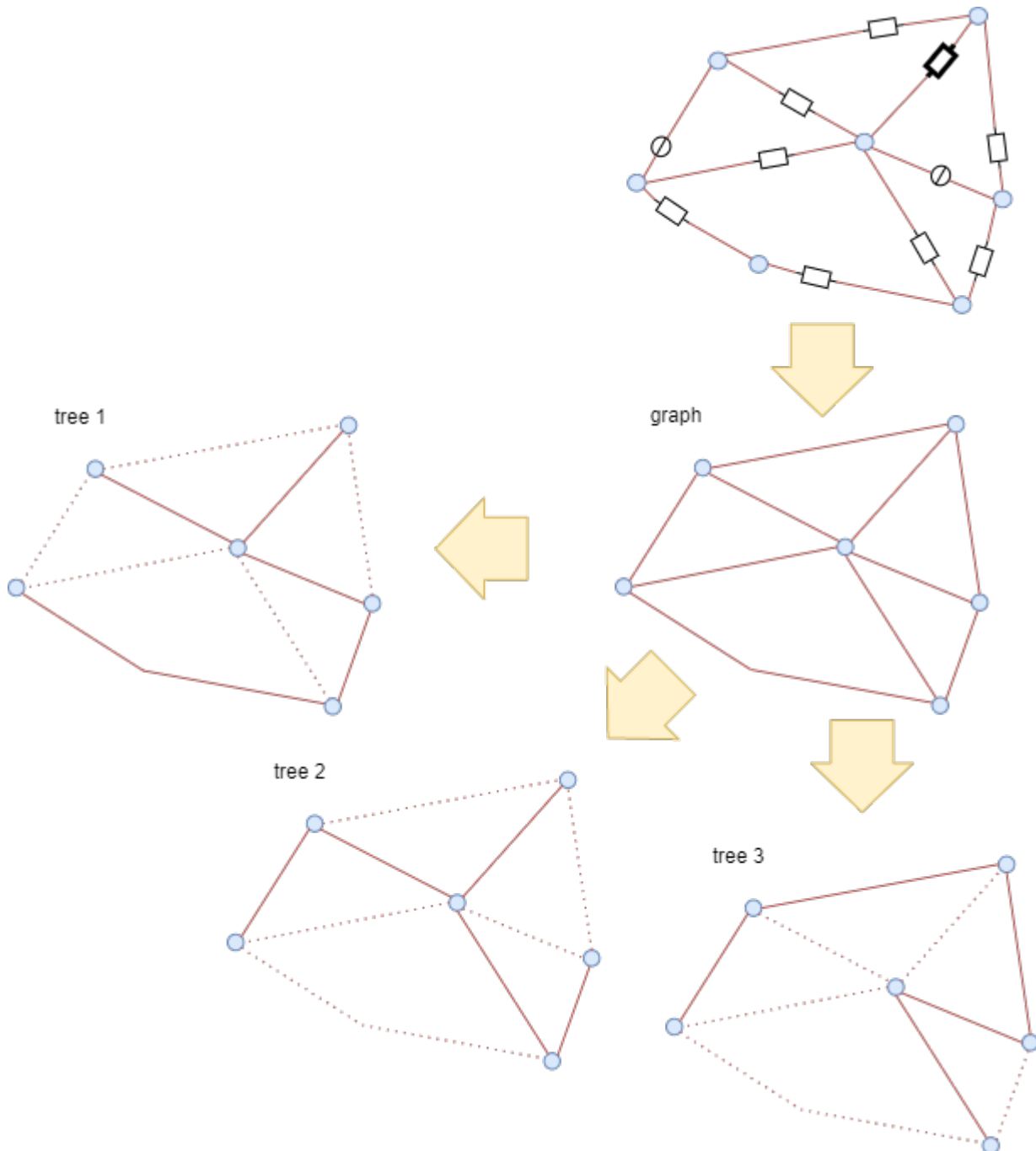

In the chapter [2. simple dc_circuits](#) the terms nodes, branches and loops have already been explained. These will now be expanded here to better explain the various network analysis methods in the following. In [figure 3](#) the **graph** of the example network is drawn. We had already seen this one too, but without knowing that this is called a graph!

But the important thing is: In this graph only the (real) nodes are drawn. Nodes are by definition the connection of more than two branches. Accordingly, the connection between R_{10} and R_7 is not a node¹⁾ ! For this reason also the blue circle as sign for nodes is omitted here.

A concept that has not yet appeared is that of the complete tree. For this, some (mathematical) graph theory is needed. There, too, the terms nodes and loops are used as before. A **tree** here is a special kind of graph. The graph in [figure 3](#) shows several loops.

Now a tree is characterized precisely by the fact that it contains no loops. Three different trees are drawn in the picture. From a given network, many different trees can be created (depending on the number of nodes).

Among the different trees, there are now some in which each node connects two or fewer loops.²⁾ These are called **complete trees** (occasionally also **Hamilton way**). Complete trees can also be understood as this shows a path through the network where all nodes are visited only exactly once.

Tree 3 in figure 3 is now just one of the possible complete trees of this network.

The branches in complete trees are now distinguished according to their membership:

- **tree branches** belong to the complete tree (solid lines in figure 3).
- **Connecting branches** do not belong to the complete tree (dotted lines in figure 3).

Why does the swing to graph theory make sense now? The trick is that by defining the complete tree, all loops have just been removed. Conversely, a new (independent) loop can be created by each connecting branch. So if the number of independent loop equations m is sought, this is just equal to the number of connecting branches.

To do this, proceed as follows:

1. Determine the number of (real) nodes k .
2. Determine the number of branches z
3. The number of tree branches b is now $k-1$. (each node is traversed only once; at the last node there is no further branch).
4. The number of connecting branches v is given by "All branches minus tree branches": $v = z - b = z - k + 1$

Thus, the number of independent loop equations m is findable by counting the nodes k and branches z over $m = v = z - k + 1$.

This explanation can also be heard again in [this video](#) and is explained again clearly via [StudyFlix](#).

4.2 Branch Current Procedure



Fig. 4: example circuit

In the branch current method now "simply times" (almost) all equations of the circuit. Specifically, for each node and each independent loop, the node and loop equations are written down:

- for all nodes k respectively the equation: $\sum_{k=0}^{N_k} I_k = 0$
- for all independent loops m respectively the equation: $\sum_{m=0}^{N_m} U_m = 0$

These matrices can be solved using, for example, the [Gaußes Eliminationsverfahren](#).

Another examples in videos

In video 1 you will learn:

1. writing down the given circuit and sizes
2. drawing in and designating the nodes
3. draw in and label the loops
4. draw and label the branch currents
5. drawing in and designating the branch voltages

for a simple circuit

Branch current analysis Example 1/3



In video 2 you will learn :

1. writing down the given circuit and sizes
2. drawing in and designating the nodes
3. draw in and label the loops
4. draw and label the branch currents
5. drawing in and designating the branch voltages

for a more complex circuit

Branch current analysis 2/3



Video 3 describes the following steps:

1. writing down the given circuit and sizes
2. drawing in and designating the nodes
3. draw in and label the loops
4. draw and label the branch currents
5. drawing in and designating the branch voltages
6. set up node equations and loop equations
7. convert to matrix notation

Branch current analysis 3/3



8. solve the matrix

In the [Video 4](#) (not embedded here), will teach you how to solve a matrix by using a calculator:

9. inserting the numerical values to a calculator

10. calculating the matrix with a calculator

Exercise 4.2.1

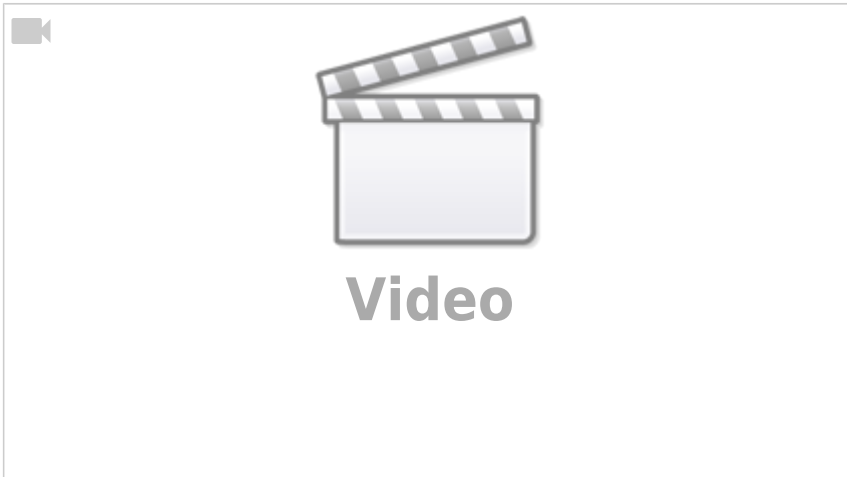

Exercise 4.2.2

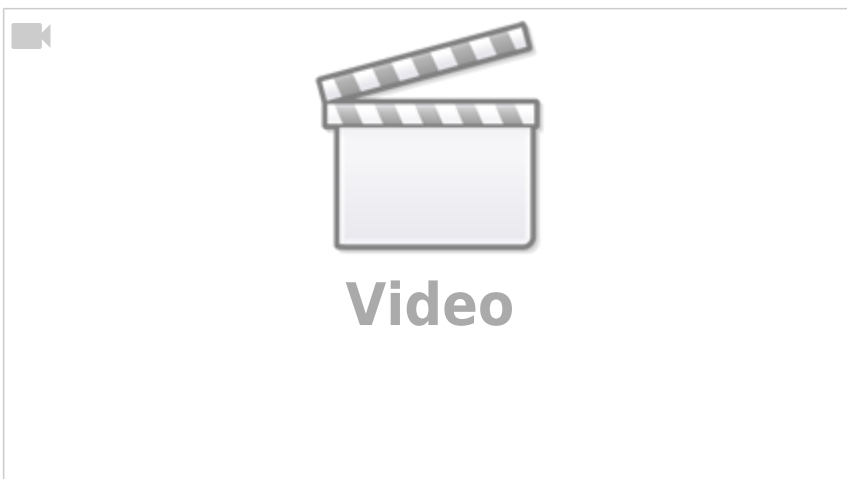

4.3 mesh current method

In the [mesh current method](#), only for all loops m each equation:

$\sum_{j=0}^{N_j} U_j = 0$ are considered. However, these are represented in the form $R \cdot I = U$.

The advantage here is that the number of equations to be solved is reduced to the number of independent loop currents.

These can also be considered as matrix equations and can be solved with the rules of (mathematical) art.

In video 1, the mesh current method is applied by means of an example.

mesh current method



Also in video 2, the mesh current method is applied by means of an example.

mesh current method



In the [Video 3](#) (not embedded here) shows in detail how the loop current method can be derived.

4.4 Nodal potential method

In the [nodal potential method](#), only the equation: $\sum_{i=0}^{N_i} I_i = 0$ are considered for all nodes k respectively. However, these are expressed in the form $\frac{1}{R} \cdot U = I$ and $G \cdot U = I$ respectively.

The advantage here is that the number of equations to be solved is reduced to the number of existing nodes (minus 1).

These can also be considered as matrix equations and can be solved with the rules of (mathematical) art.

In Video 1, the idea behind node potential analysis is simply explained.

Simple example of node potential analysis



Video 2 also uses the nodal potential method with an example.

more complex example of a node potential analysis



In the [Video 3](#) (not embedded here) shows in detail how the nodal potential method can be derived.

4.5 Superposition method / Superposition principle

The superposition principle shall first be illustrated by some examples

Example 1 - from consulting industry interviews

Task: Three students are to fill a pool. If Alice were to fill it alone, she would need 2 days. Bob would need 3 days and Carol would need 4 days. How long would it take all three to fill a pool if they helped together?

The question sounds far off topic at first, but is directly related. The point is that to solve it, filling the pool is assumed to be linear. So Alice will fill $\frac{1}{2}$, Bob $\frac{1}{3}$, and Carol $\frac{1}{4}$ of the pool per day. So on the first day, $\frac{1}{2} + \frac{1}{3} + \frac{1}{4} = \frac{6 + 4 + 3}{12} = \frac{13}{12}$ of the pool filled.

So the three of them need $\frac{12}{13}$ of a day.

However, this solution path is only possible because in linear systems the partial results can be

added.

Example 2 - Spring Force and Travel



Fig. 5: mechanical spring

Task: A mechanical, linear spring is deflected with masses m_1 and m_2 in the Earth's gravitational field (see figure 5). What is the magnitude of the deflection if both masses are attached simultaneously?

Again, a linear law is used here:
$$\vec{s} = f(\vec{F}) = -D \cdot \vec{F}$$

The (seemingly trivial) approach applies here:
$$\vec{s}_{1+2} = f(\vec{F}_1 + \vec{F}_2) = -D \cdot (\vec{F}_1 + \vec{F}_2) = -D \cdot \vec{F}_1 - D \cdot \vec{F}_2 = f(\vec{F}_1) + f(\vec{F}_2) = \vec{s}_1 + \vec{s}_2$$

Notice:

In a physical system in which effect and cause are linearly related, the effect of each cause can first be determined separately. The total effect is then the sum of the individual effects.

For electrical engineering this principle was described by [Hermann von Helmholtz](#):

The currents in the branches in a linear network are equal to the sum of the partial currents in the branches concerned caused by the individual sources.

Thus, in the superposition method, the current (or voltage) sought in a circuit with multiple sources can be viewed as a superposition of the resulting currents (or voltages) of the individual sources. Simple view of the superposition principle

The “recipe” for the overlay is as follows:

1. Choose next source x

2. Replace all ideal sources with their respective equivalent resistors:
 1. ideal voltage sources by short circuits
 2. ideal current sources by an open line
3. Calculate the partial currents sought in the branches considered.
4. Go to the next source $x=x+1$ ³⁾ and to point 2, as long as the partial currents of all sources have not been calculated.
5. Add up the partial currents in the branches under consideration, observing the correct sign.



This procedure is explained again in more detail using examples in the two videos on the right.

more complex example of the superposition method



Example

Fig. 6: example circuit with superposition

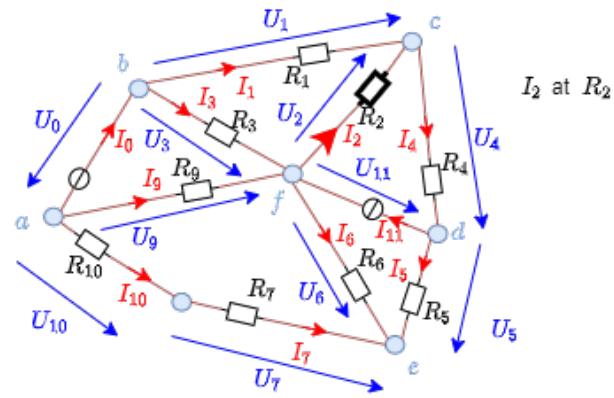

Focus onto voltage source U_0

Focus onto current source I_{11}

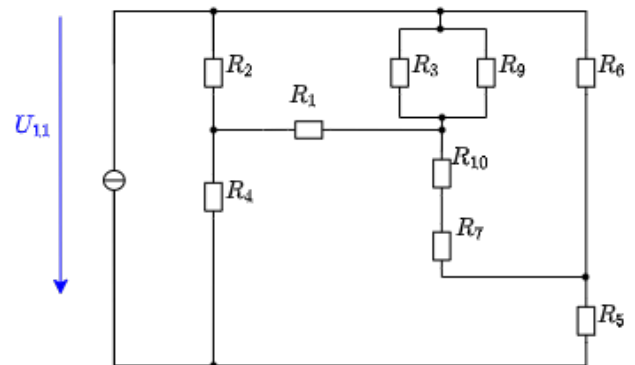
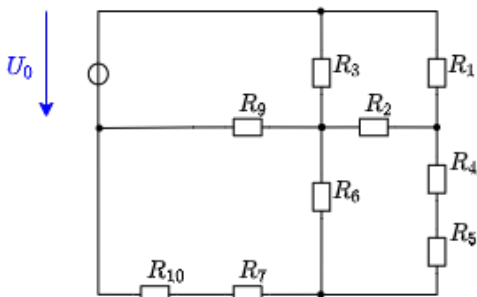
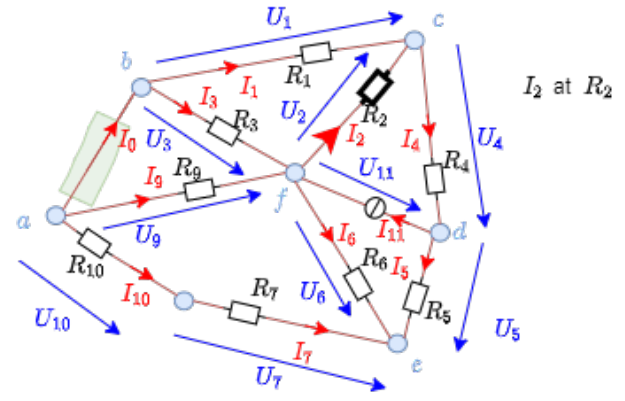
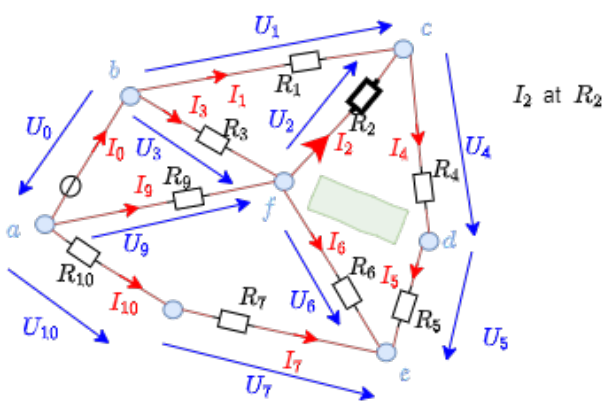

Exercise 4.5.1 Converting a bipolar signal to a unipolar signal

Imagine you want to develop a circuit that conditions a sensor signal so that it can be processed by a microcontroller. The sensor signal is in the range $U_{sens} \in [-15...15V]$, the microcontroller input can read values in the range $U_{uC} \in [0...3.3V]$. The sensor can supply a maximum current of $I_{sens,max}=1mA$. For the internal resistance of the microcontroller input applies: $R_{uC} \rightarrow \infty$

For conditioning, the input signal is to be fed via the series resistor R_3 to the center

potential of a voltage divider $R_1 - R_2$ with R_1 against $U_{\text{UC,max}}$ (similar circuit see in simulation on the right).

1. Find the relationship between R_1 , R_2 and R_3 using superposition.
2. Find the relationship between R_1 , R_2 and R_3 using star-delta transformation.
3. What is the input resistance $R_{\text{in}}(R_1, R_2, R_3)$ of the circuit (viewed from the sensor)?
4. What is the maximum allowed input resistance $R_{\text{in}}(R_1, R_2, R_3)$ for the sensor to still deliver current?
5. Determine suitable values for R_1 , R_2 and R_3 .
6. What values for R^0_1 , R^0_2 , and R^0_3 from the [E24 series](#) can be used to do this?

Exercise 4.5.3 -Variation: open circuit voltage via superposition (exam task, approx. 12 % of a 60-minute exam, WS2020)

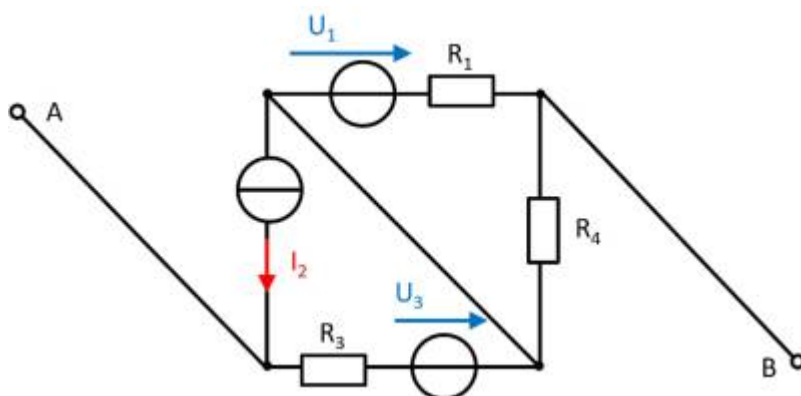

A circuit is given with the following parameters

$$R_1 = 5 \text{ } \Omega$$

$$U_1 = 2 \text{ V}$$

$$I_2 = 1 \text{ A}$$

$$R_3 = 20 \text{ } \Omega$$

$$U_3 = 8 \text{ V}$$

$$R_4 = 10 \text{ } \Omega$$

Determine the open circuit voltage between A and B using the principle of superposition.

Solution

Case 1: For this case is $I_2 = 0 \text{ A}$ and $U_3 = 0 \text{ V}$. The voltage is at R_4 .

$$U_{\text{AB},1} = \frac{R_4}{R_1 + R_4} U_1 = \frac{10\ \Omega}{5\ \Omega + 10\ \Omega} \cdot 2\ \text{V} = 1.33\ \text{V}$$
 Case 2: For this case is $U_1 = 0\ \text{V}$ and $U_3 = 0\ \text{V}$. The voltage is at R_3 .

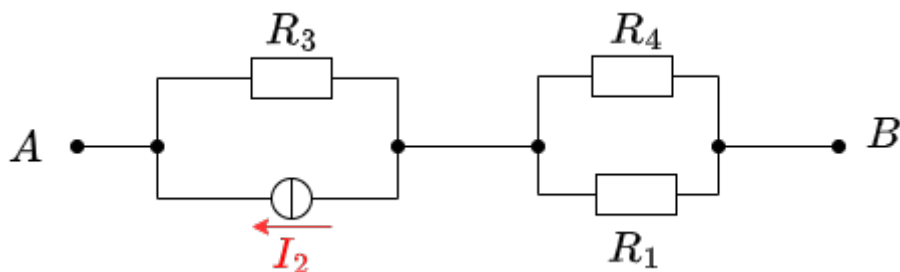

$$U_{\text{AB},2} = R_3 I_2 = 20\ \Omega \cdot 1\ \text{A} = 20\ \text{V}$$
 Case 3: For this case is $U_1 = 0\ \text{V}$ and $I_2 = 0\ \text{A}$. The voltage comes from the source U_3 .



$$U_{\text{AB},3} = 8 \text{ V}$$
 Superposition means adding the voltages of all three cases.

$$U_{\text{AB}} = U_{\text{AB},1} + U_{\text{AB},2} + U_{\text{AB},3} = 1.33 \text{ V} + 20 \text{ V} + 8 \text{ V}$$

Final value

$$U_{\text{AB}} = 29.333... \text{ V} \rightarrow 29.3 \text{ V}$$

Exercise 4.5.4 - Variation: open circuit voltage via superposition (exam task, approx. 12 % of a 60-minute exam, WS2020)



A circuit is given with the following parameters

$$I_1 = 2 \text{ A}$$

$$R_2 = 5 \text{ } \Omega$$

$$R_3 = 20 \text{ } \Omega$$

$$U_3 = 1 \text{ V}$$

$$R_4 = 10 \text{ } \Omega$$

$$U_4 = 3 \text{ V}$$

Determine the open circuit voltage between A and B using the principle of superposition.

1)

sometimes such connections are called "fake nodes"

2)

Here we now depart from the previous electrotechnical notion of node (= connecting more than 2 branches). The mathematical notion of node does not have this restriction

3)

$x=x+1$ is not meant mathematically, but procedurally as in the programming language C

From:

<https://wiki.mexle.org/> - **MEXLE Wiki**

Permanent link:

https://wiki.mexle.org/electrical_engineering_1/network_analysis?rev=1634431387

Last update: **2021/10/17 02:43**

