

task_kricv9fh7haauo6q_with_calculation

Student Group

First Name	Surname	Matrikel Nr.

Table of Contents

complex impedance, exam ee1 WS2022

Exercise 1.1 : Complex Impedance Circuit

(written test, approx. 15 % of a 60-minute written test, WS2022)

A circuit designed to filter the noise from a signal shall be analysed.

The input is given by a voltage source $u(t) = 3.0 \text{ V} \cdot \sin(2\pi \cdot 15 \text{ kHz} \cdot t)$ with an internal resistance of $10 \text{ }\Omega$.

This linear source is connected with an inductor of $330 \text{ }\mu\text{H}$ and a capacitor of $0.22 \text{ }\mu\text{F}$, all in series.

1. Draw the circuit diagram of the given circuit.
Label all components, voltages and currents.

Result

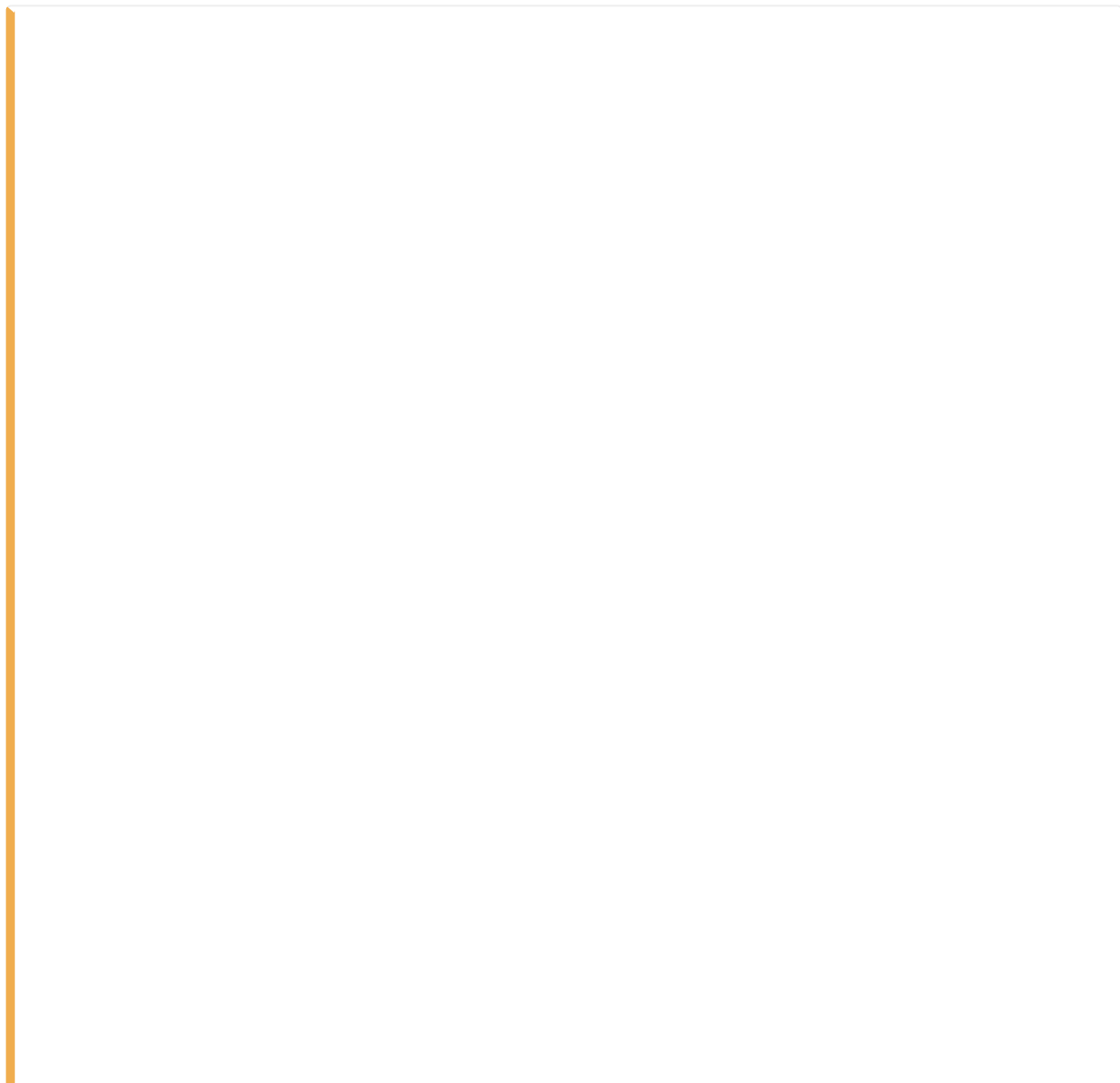

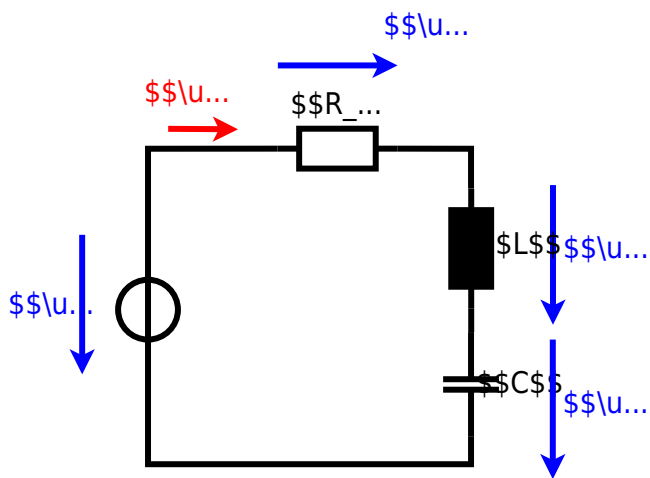

2. Calculate the single impedance \underline{Z}_C , \underline{Z}_L such as \underline{Z} of the overall circuit.

Solution

$$\begin{aligned} \underline{Z}_C &= \frac{1}{2\pi \cdot f \cdot C} = \frac{1}{2\pi \cdot 15 \text{ kHz} \cdot 0.22 \text{ }\mu\text{F}} \\ \underline{Z}_L &= 2\pi \cdot f \cdot L = 2\pi \cdot 15 \text{ kHz} \cdot 0.22 \text{ }\mu\text{F} \\ \underline{Z}_C &= \frac{1}{2\pi \cdot f \cdot C} = \frac{1}{2\pi \cdot 15 \text{ kHz} \cdot 330 \text{ }\mu\text{H}} \\ \underline{Z} &= R + \underline{Z}_L + \underline{Z}_C = R + j \cdot \underline{Z}_L - j \cdot \underline{Z}_C = R + j \cdot (\underline{Z}_L - \underline{Z}_C) \\ |\underline{Z}| &= \sqrt{R^2 + (\underline{Z}_L - \underline{Z}_C)^2} \end{aligned}$$

Final result

$$\begin{aligned} \underline{Z}_L &= 31.1 \text{ }\Omega \\ \underline{Z}_C &= 48.2 \text{ }\Omega \\ \underline{Z} &= 19.8 \text{ }\Omega \end{aligned}$$

3. Draw the three impedance phasors \underline{Z}_C , \underline{Z}_L and \underline{Z}_R in a diagram. Choose an appropriate scaling factor and write it down.

Result

4. Calculate the current \underline{I} .

Solution

$$\begin{aligned} Z &= \frac{\hat{U}}{\hat{I}} \quad \hat{I} = \frac{\hat{U}}{Z} \\ \end{aligned}$$

$$\begin{aligned} \text{With } I = \frac{1}{\sqrt{2}} \cdot \hat{I}: \quad I &= \\ \frac{1}{\sqrt{2}} \cdot \frac{\hat{U}}{Z} \quad &= \frac{1}{\sqrt{2}} \cdot \\ \frac{3.0 \text{ V}}{19.28 \text{ } \Omega} \quad & \end{aligned}$$

Final result

$$I = 107 \text{ mA}$$

From:
<https://wiki.mexle.org/> - MEXLE Wiki

Permanent link:
https://wiki.mexle.org/electrical_engineering_1/task_kricv9fh7haauo6q_with_calculation?rev=1678465843

Last update: 2023/03/10 17:30

