

task_tb6pi8dgh0m2e2pw_with_calculation

Student Group

First Name	Surname	Matrikel Nr.

Table of Contents

Charging Capacitors, dc network analysis, pure resistor network simplification, delta wye transformation, exam ee1 WS2022

Exercise 1.1 : Charge Capacitors

(written test, approx. 16% of a 60-minute written test, WS2022)

The circuit shown in the following is used to control the brightness when turning on a small light bulb.

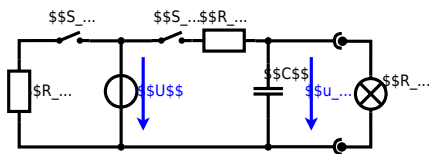

The circuit contains a voltage source $U=12\text{ V}$, a switch S_1 , a resistor of $R_1=20\ \Omega$ and a capacitor of $C=100\ \mu\text{F}$.

The switch S_2 to an additional consumer R_2 will be considered to be open for the first tasks. At the moment $t_0=0\text{ s}$ the switch S_1 is closed, the voltage across the capacitor is $u_c(t_0)=0\text{ V}$.

1. First do not consider the light bulb - it is not connected to the RC-circuit. Calculate the point of time t_1 when $u_c(t_1)=0.5 \cdot U$.

Solution

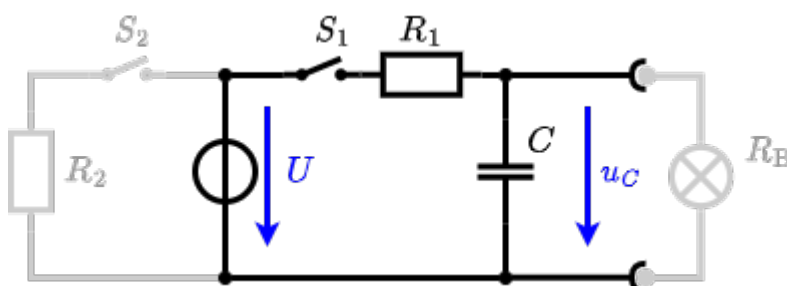

So, here only R_1 and C gives the time constant: $\tau = R_1 \cdot C$

The following formula describes the time course of $u_C(t)$ which has to be $u_C(t_1) = 0.5 \cdot U$:
$$u_C(t) = U \cdot (1 - e^{-t/\tau}) = 0.5 \cdot U$$
 It has to be rearranged to t
$$(1 - e^{-t/\tau}) = 0.5 \implies e^{-t/\tau} = 0.5 \implies -t/\tau = \ln(0.5) \implies t = \tau \cdot \ln(0.5) = R_1 \cdot C \cdot \ln(0.5)$$

Final result

$$t = 1.39 \text{ ms}$$

2. Calculate the overall energy dissipated by R_1 while charging the capacitor 0 V to 12 V .

Solution

$$\Delta W_R = \Delta W_C = \frac{1}{2} \cdot C \cdot U^2 = \frac{1}{2} \cdot 100 \mu\text{F} \cdot (12 \text{ V})^2$$

Final result

$$\Delta W_R = 7.2 \text{ mWs}$$

3. Now, consider the light bulb as a resistor of $R_B = 20 \Omega$, and ignore again the left side (S_2 is open). The voltage across the capacitor is again 0 V at the moment $t_0 = 0 \text{ s}$ when the switch S_1 is closed. Calculate the voltage $u_C(t_2)$ across the capacitor at $t_2 = 1 \text{ ms}$ after closing the switch.

Hint: To solve this, first create an equivalent linear voltage source from U , R_1 and R_B .

Solution

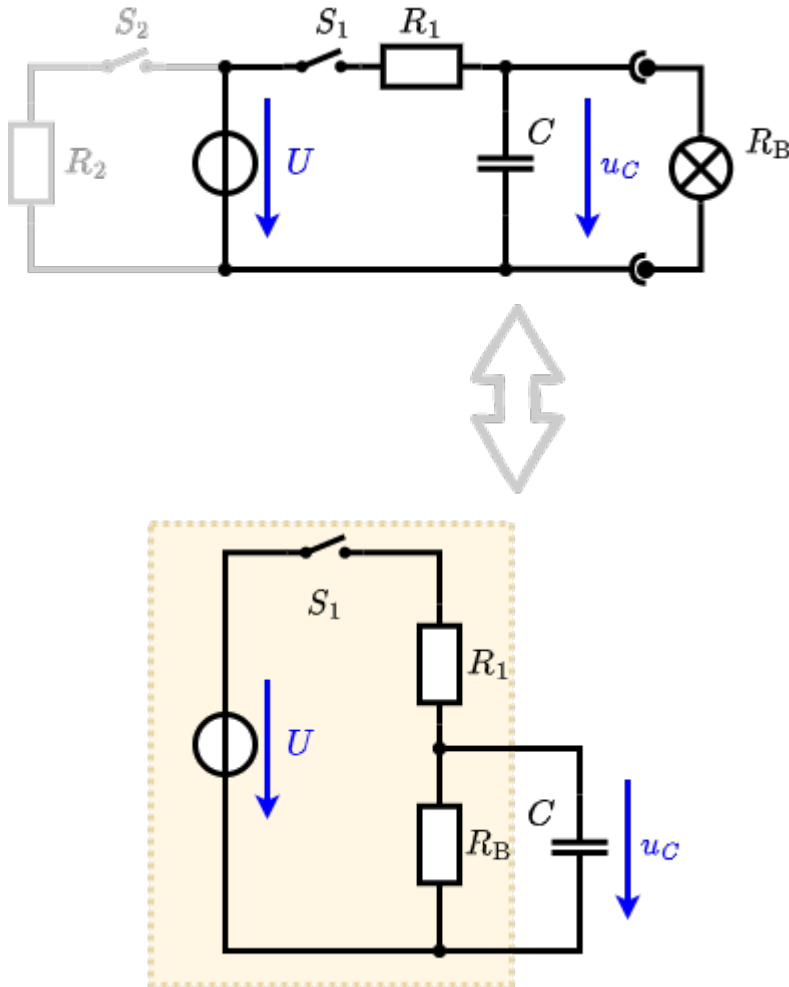

An equivalent linear voltage source can be given with \$U\$, \$R_1\$ and \$R_B\$ as seen in yellow.

Therefore, the voltage of the equivalent linear voltage source is: $U_s = U \cdot \frac{R_B}{R_1 + R_B} = \frac{1}{2} \cdot U$ The internal resistance is given by substituting the ideal voltage source with its resistance ($=0 \Omega$, short-circuit).

$$R_i = R_1 \parallel R_B = 10 \Omega$$

$$u_c(t_2) = U_s \cdot (1 - e^{-t_2/(R_i \cdot C)}) = \frac{1}{2} \cdot U \cdot (1 - e^{-1\text{ms}/(10 \Omega \cdot 100 \mu\text{F})})$$

Final result

$$u_c(t_2) = 3.79 \text{ V}$$

4. Explain (without calculation) how the situation in 3. would change once also \$S_2\$ is closed from the beginning on.

Final result

It does not change anything. The ideal voltage source U provides the voltage of $U=12\text{V}$ independent of this resistor.

On an alternative view, one can try to create an equivalent linear voltage source again. Then, the internal resistance is given by substituting the ideal voltage source is again short-circuiting R_2 .

From:

<https://wiki.mexle.org/> - MEXLE Wiki

Permanent link:

https://wiki.mexle.org/electrical_engineering_1/task_tb6pi8dgh0m2e2pw_with_calculation?rev=1676180610

Last update: **2023/02/12 06:43**

