

task_p8yrdjr60k6bvc4n_with_calculation

Student Group

First Name	Surname	Matrikel Nr.

Table of Contents

Exercise E1 (Dis)Charging Capacities (written test, approx. 14 % of a 60-minute written test, SS2023)	2
---	---

charging, capacities, exam ee1 SS2023

**Exercise E1 (Dis)Charging Capacities
(written test, approx. 14 % of a 60-minute written test, SS2023)**

The circuit below is a circuit with a voltage source U and a capacitor C . The circuit is shown in the drawing below. What will be the results on the page of the circuit at t_0 switches to the situation shown in the drawing. What is the time constant?

- $C_1 = 200 \text{ nF}$

Solution: $R_1 = 8.0 \text{ k}\Omega$
 Solution: $\tau = (R_1 + R_3) \cdot C = 3.6 \text{ ms}$
 $U_C = U \cdot \frac{R_2}{R_1 + R_2} = 10 \text{ V} \cdot \frac{17 \text{ k}\Omega}{8 \text{ k}\Omega + 17 \text{ k}\Omega} = 5.9 \text{ V}$
 $I = \frac{U}{R_1 + R_2} = \frac{10 \text{ V}}{25 \text{ k}\Omega} = 0.4 \text{ mA}$

The current of the source flows through the circuit consisting of C in parallel with R_1 and R_2 . Without the parallel resistors, the current source would charge the capacitor "to infinity" ($C \rightarrow \infty$). This is here limited by the parallel resistors R_1 and R_2 and S_2 is closed. Then, the source U drives the current through the series circuit given by S_1 , C , R_1 and R_2 .

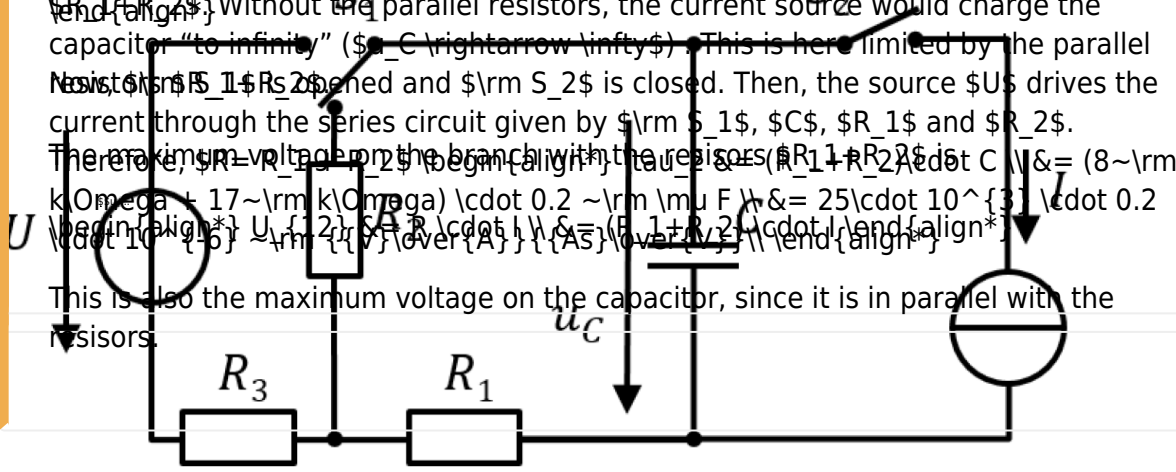

Therefore, the voltage on the branch with the resistors ($R_1 + R_2$) is $U_C = (8 \text{ k}\Omega + 17 \text{ k}\Omega) \cdot 0.2 \text{ mA} = 25 \cdot 10^3 \cdot 0.2 \cdot 10^{-3} \text{ V} = 5 \text{ V}$. This is also the maximum voltage on the capacitor, since it is in parallel with the resistors.

Before t_0 all switches are switched as shown and the capacitor is fully discharged. At $t_0 = 0 \text{ s}$ the switch S_1 shall switch to the voltage source.

1. Calculate the time constant for charging the capacitor.

Solution

The time constant is generally given as: $\tau = R \cdot C$

Once S_1 is closed and S_2 is open at t_0 , the source U drives the current through the series circuit given by S_1 , C , R_1 and R_3 .

Therefore, $R = R_1 + R_3$
 $\tau_1 = (R_1 + R_3) \cdot C = (8 \text{ k}\Omega + 7 \text{ k}\Omega) \cdot 0.2 \text{ }\mu\text{F} = 15 \cdot 10^3 \cdot 0.2 \cdot 10^{-6} \text{ s} = 3 \text{ ms}$

Solution

Both courses of the voltage for charging and discharging are described with an exponential function. However, the curve for charging increases first steep and flattens out for longer time scales ($\propto (1 - e^{-x})$).

From:
<https://wiki.mexle.org/> - **MEXLE Wiki**

Permanent link:
https://wiki.mexle.org/electrical_engineering_and_electronics/task_p8yrdjr60k6bvc4n_with_calculation

Last update: **2023/08/17 06:45**

