

Block 05 — Resistive Networks

Student Group

First Name	Surname	Matrikel Nr.

Table of Contents

- Block 05 — Resistive networks** 3
- Learning objectives* 3
- Preparation at Home* 3
- 90-minute plan* 3
- Core Content** 3
- Unloaded voltage divider 3
- Exercise 5
- The loaded Voltage Divider 5
- Bridge networks (Wheatstone) 7
- Strategy for network reduction 8
- Exercises** 10
- Exercise 2.4.3 Three Resistors 10
- Exercise 2.5.2 loaded voltage divider I 10
- Exercise 2.5.3 loaded voltage divider II 11
- Exercise 2.5.4 Application of the loaded voltage divider - motor 11
- Exercise 2.5.5 Examples of the calculation of loaded voltage dividers 12
- Exercise 2.5.6 Example of a loaded voltage divider: Explanation without calculation (German) 12
- Exercise 2.7.1 Circuit Simplification Exercise I (in German) 13
- Exercise 2.7.2 Circuit Simplification Exercise II + III (in German) 13
- Exercise 2.7.3 Circuit Simplification Exercise IV (in German) 13
- Exercise 2.7.4 Circuit Simplification Exercise V (in German) 14
- Exercise 2.7.5 Circuit Simplification Exercise VI (in German) 14
- Exercise 2.7.7 Simplifying Circuits (exam task, about 8% of a 60-minute exam, WS2020) 14
- Exercise 2.7.8: Simplifying Circuits II (written exam task, approx 8% of a 60-minute written exam, WS2020) 16
- Exercise 2.7.9 - Variation: Simplifying Circuits II (written exam task, approx 8% of a 60-minute written exam, WS2020) 19

Exercise 2.7.10 - Variation: Simplifying Circuits III (written exam task, approx 8% of a 60-minute written exam, WS2020)	20
Embedded resources	21
Summary (take-away)	21
Preparation for next block	21

Block 05 — Resistive networks

Learning objectives

After this 90-minute block, you can

- reduce series/parallel resistor networks to an equivalent resistance R_{eq} ,
- apply **voltage divider** (unloaded & loaded) and **current divider** rules,
- recognize and analyze **bridge** circuits (Wheatstone; balance condition),
- check results by units and by “sanity bounds” (e.g., R_{eq} in parallel is below the smallest branch).

Preparation at Home

And again:

- Please read through the following chapter.
- Also here, there are some clips for more clarification under 'Embedded resources' (check the text above/below, sometimes only part of the clip is interesting).

For checking your understanding please do the following exercises:

- 2.5.3
- 2.7.8

90-minute plan

- 0–10 min — Recap KCL/KVL; sign conventions.
- 10–30 min — Series & parallel; quick numeric checks.
- 30–55 min — Voltage dividers (unloaded → loaded); potentiometer view; pitfalls.
- 55–70 min — Current divider; typical use.
- 70–85 min — Bridge circuits; balance; measurement idea.
- 85–90 min — Wrap-up quiz; assign exercises.

Core Content

Unloaded voltage divider

The series circuit of two resistors R_1 and R_2 shall be considered now. This situation occurs in many practical applications e.g. in a [potentiometer](#).

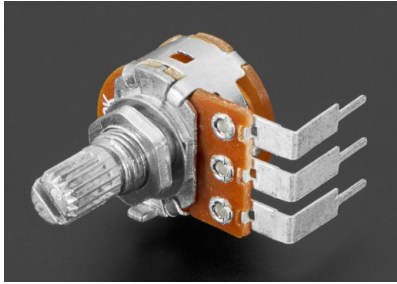

adafruit@flickr.com, CC BY-NC-SA 2.0

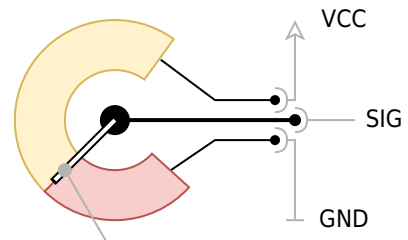

Fig. 1: potentiometer

Text is not SVG - cannot display

moveable wiper

In [figure 2](#) this circuit is shown.

Fig. 2: unloaded voltage divider

potentiometer as...

Via Kirchhoff's voltage law, we get

$$\boxed{\frac{U_1}{U} = \frac{R_1}{R_1 + R_2} \rightarrow U_1 = k \cdot U}$$

The ratio $k = \frac{R_1}{R_1 + R_2}$ also corresponds to the position on a potentiometer.

Exercise

Fig. 3: unloaded voltage divider

In the simulation in [figure 3](#) an unloaded voltage divider in the form of a potentiometer can be seen. The ideal voltage source provides 5 V . The potentiometer has a total resistance of $1 \text{ k}\Omega$. In the configuration shown, this is divided into 500Ω and 500Ω .

1. What voltage U_{O} would you expect if the switch were closed? After thinking about your result, you can check it by closing the switch.
2. First, think about what would happen if you would change the distribution of the resistors by moving the wiper ("intermediate terminal"). You can check your assumption by using the slider at the bottom right of the simulation.
3. At which position do you get a $U_{\text{O}} = 3.5 \text{ V}$?

The loaded Voltage Divider

If - in contrast to the abovementioned, unloaded voltage divider - a load R_{L} is connected to the output terminals ([figure 4](#)), this load influences the output voltage.

Fig. 4: loaded voltage divider

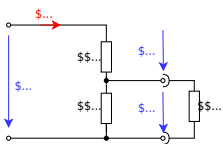

A circuit analysis yields:

$$U_1 = U \cdot \frac{1}{1 + \frac{R_2}{R_L} + \frac{R_2}{R_1}}$$

An alternative representation of the formula sticks more to the application.

It uses:

1. the position on a potentiometer given as $k = \frac{R_1}{R_1 + R_2}$ and
2. the sum of resistors $R_{\text{sum}} = R_1 + R_2$.

Both are more often used in real setups.

Mathematically, both parameter lead to $R_1 = k \cdot R_{\text{sum}}$ and $R_2 = (1 - k) \cdot R_{\text{sum}}$.

When these two relations are included in the formula above, we get:

$$U_1 = U \cdot k \cdot \frac{1}{1 + k \cdot (1 - k) \cdot \frac{R_{\text{sum}}}{R_L}}$$

Figure 5 shows the ratio of the output voltage U_1 to the input voltage U (y-axis), in relation to the ratio $k = \frac{R_1}{R_1 + R_2}$. In principle, this is similar to figure 2, but here it has another dimension: multiple graphs are plotted. These differ by the ratio $\frac{R_{\text{sum}}}{R_L}$.

Fig. 5: Voltage curve of the loaded voltage divider

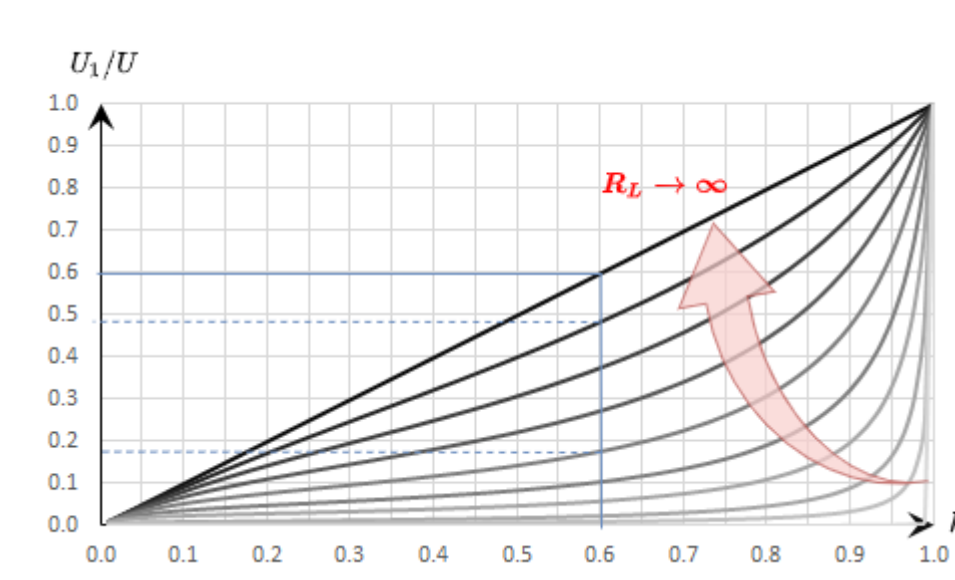

What does this diagram tell us? This shall be investigated by an example. First, assume an unloaded voltage divider with $R_2 = 4.0 \text{ k}\Omega$ and $R_1 = 6.0 \text{ k}\Omega$, and an input voltage of 10 V . Thus $k = 0.60$, $R_s = 10 \text{ k}\Omega$ and $U_1 = 6.0 \text{ V}$. Now this voltage divider is loaded with a load resistor. If this is at $R_L = R_1 = 10 \text{ k}\Omega$, k reduces to about 0.48 and U_1 reduces to 4.8 V - so the output voltage drops. For $R_L = 4.0 \text{ k}\Omega$, k becomes even smaller to $k=0.375$ and $U_1 = 3.75 \text{ V}$. If the load R_L is only one-tenth of the resistor $R_s = R_1 + R_2$, the result is $k = 0.18$ and $U_1 = 1.8 \text{ V}$. The output voltage of the unloaded voltage divider (6.0 V) thus became less than one-third.

What is the practical use of the (loaded) voltage divider?
 Here are some examples:

- Voltage dividers are in use for controlling the output of power supply ICs (see [Voltage Dividers in Power Supplies](#)). In order not to create a loaded voltage divider, a range for the resistance is given here.
- Another “invisible” voltage divider is for example in the electrical system of a car. As we will learn in the next chapters, voltage supplies have internal resistance (and therefore batteries, too). The other consumer in the car also represents a resistance. By this, the electrical system states an unloaded voltage divider. Given another, additional low-resistance load (e.g. the spark or the starter motor of the starter system) one can understand that there will be a voltage drop when starting the car.

Bridge networks (Wheatstone)

A four-resistor bridge can be seen as **two voltage dividers in parallel**. The detector (bridge branch) sees the **difference** of the two divider node voltages. The **balance condition** (zero detector current) is
$$\frac{R_1}{R_2} = \frac{R_3}{R_4} \iff R_1 R_4 = R_2 R_3$$
 Use this to check sensor bridges (strain gauges etc.) or to compute unknown R . (Derivation via equal divider ratios.)

If the bridge is **nearly** balanced, the midpoint voltages differ only slightly → good for small-signal sensing.

In practice you'll later buffer such nodes with high- R_{in} stages (see op-amps in [Block21](#)).

Strategy for network reduction

- Reshape (without changing node connections), then collapse **clear** series or parallel groups.
- (If blocked by a three-terminal cluster, apply Δ - Y (or Y - Δ), then collapse again. Y - Δ and Δ - Y is not covered and necessary in this course)
- Repeat until a simple ladder remains; finish with KCL/KVL if needed.

In this subchapter, a methodology is discussed, which should help to reshape circuits. The following concept works at tasks, where the total resistance, total current, or total voltage has to be calculated for a resistor network.

An example of such a circuit is given in [figure 6](#). Here I_0 is wanted. This current can be found by the (given) voltage U_0 and the total resistance between the terminals a and b . So we are looking for R_{ab} .

Fig. 6: example of a circuit 

As already described in the previous subchapters, partial circuits can also be converted into equivalent resistors step by step. It is important to note that these partial circuits for conversion into equivalent resistors may only ever have two connections (= two nodes to the “outside world”).

Fig. 7: Step-by-step solution of the example

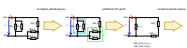

R_{L} yields to
$$U_1 = \frac{k}{k(1-k)} \frac{R_{\text{s}}}{R_{\text{L}}} + 1 U$$

Exercise 2.5.3 loaded voltage divider II

In the simulation in [figure 8](#) a loaded voltage divider in the form of a potentiometer can be seen. The ideal voltage source provides 5.00 V . The potentiometer has a total resistance of $1.00 \text{ k}\Omega$. In the configuration shown, this is divided into 500Ω and 500Ω . The load resistance has $R_{\text{L}} = 1.00 \text{ k}\Omega$.

1. What voltage U_0 would you expect if the switch were closed? This is where you need to do some math! After you calculated your result, you can check it by closing the switch.
2. At which position of the wiper do you get 3.50 V as an output? Determine the result first by means of a calculation. Then check it by moving the slider at the bottom right of the simulation.

Fig. 8: loaded voltage divider

Exercise 2.5.4 Application of the loaded voltage divider - motor

Fig. 9: Sketch of the setup

You wanted to test a micromotor for a small robot. Using the maximum current and the internal resistance ($R_{\text{M}} = 5 \Omega$) you calculate that this can be operated with a maximum of $U_{\text{M, max}} = 4 \text{ V}$. A colleague said that you can get 4 V using the setup in [figure 9](#) from a 9 V block battery.

1. First, calculate the maximum current $I_{\text{M, max}}$ of the motor.
2. Draw the corresponding electrical circuit with the motor connected as an ohmic resistor.
3. At the maximum current, the motor should be able to deliver a torque of $M_{\text{max}} = M(I_{\text{M, max}}) = 100 \text{ mNm}$. What torque would the motor deliver if you implement the setup like this? (Assumption: The torque of the motor increases proportionally to the motor current).
4. What might a setup with a potentiometer look like that would actually allow you to set a voltage between 0.5 V to 4 V on the motor? What resistance value

should the potentiometer have?

5. Build and test your circuit in the simulation below. For an introduction to online simulation, see: [online_circuit_simulator](#).

You will essentially need the following tips for this setup:

1. Routing connections can be activated via the menu: Draw » add wire. Afterward, you have to click on the start point and then drag it to the end mode.
2. Note that connections can only ever be connected at nodes. A red-marked node (e.g. at the $5\ \Omega$ resistor) indicates that it is not connected. This could be moved one grid step to the left, as there is a node point there.
3. Pressing the <ESC> key will disable the insertion of components.
4. With a right click on a component it can be copied or values like the resistor can be changed via Edit...

Fig. 10: Simulation for motor setup

Exercise 2.5.5 Examples of the calculation of loaded voltage dividers

Exercise on the voltage divider

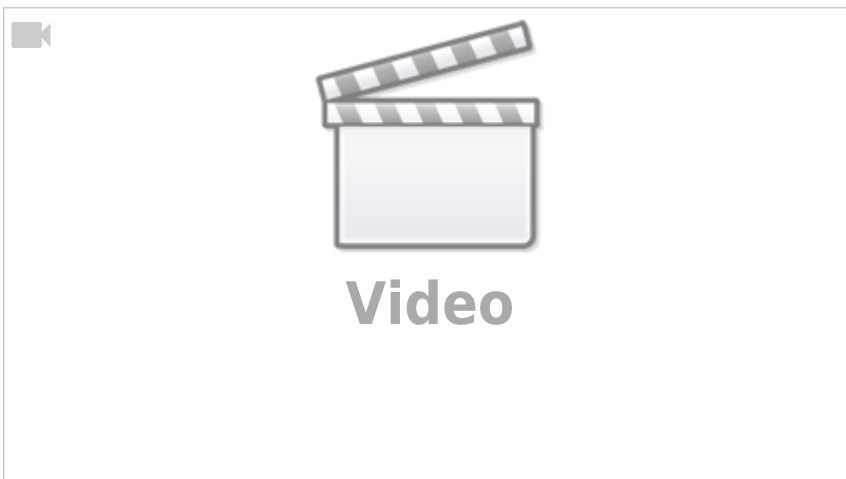

Exercise 2.5.6 Example of a loaded voltage divider: Explanation without calculation (German)

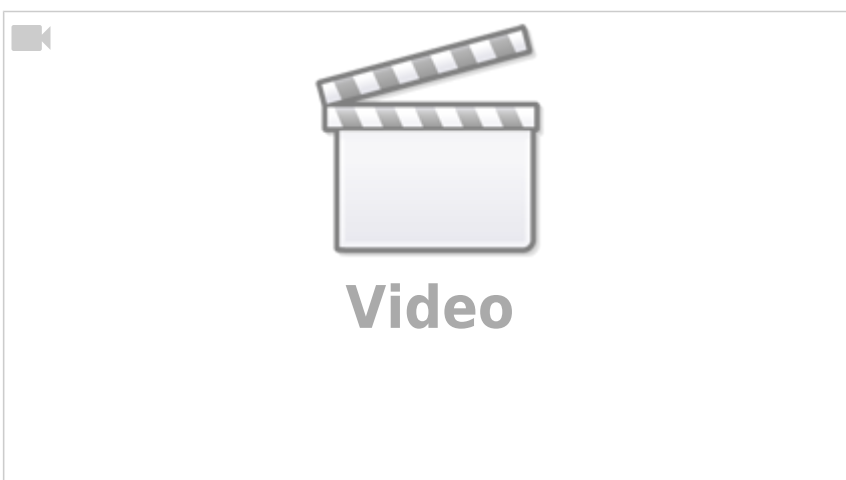

Exercise 2.7.1 Circuit Simplification Exercise I (in German)

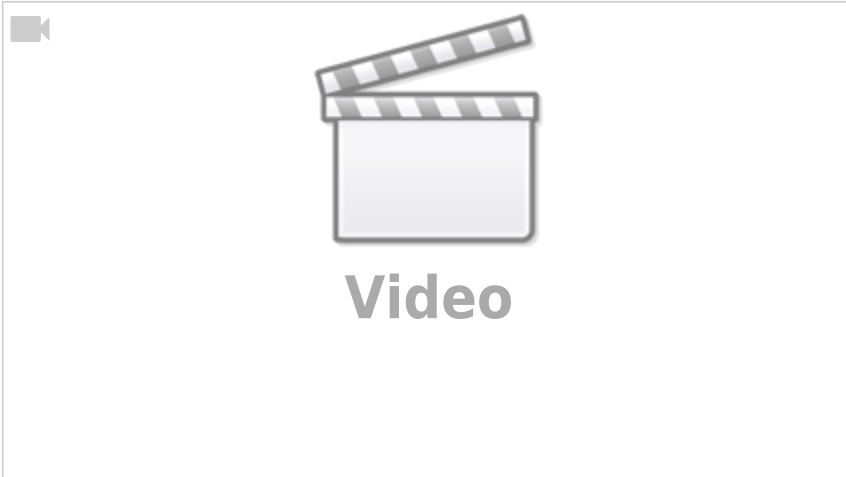

Exercise 2.7.2 Circuit Simplification Exercise II + III (in German)

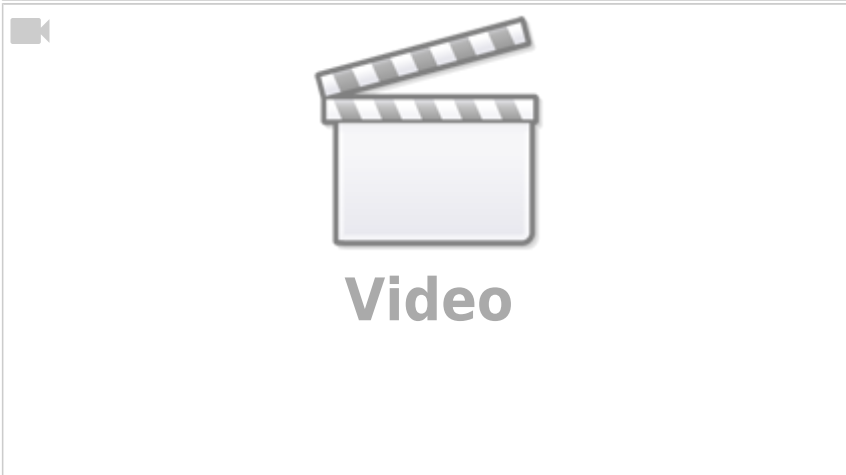
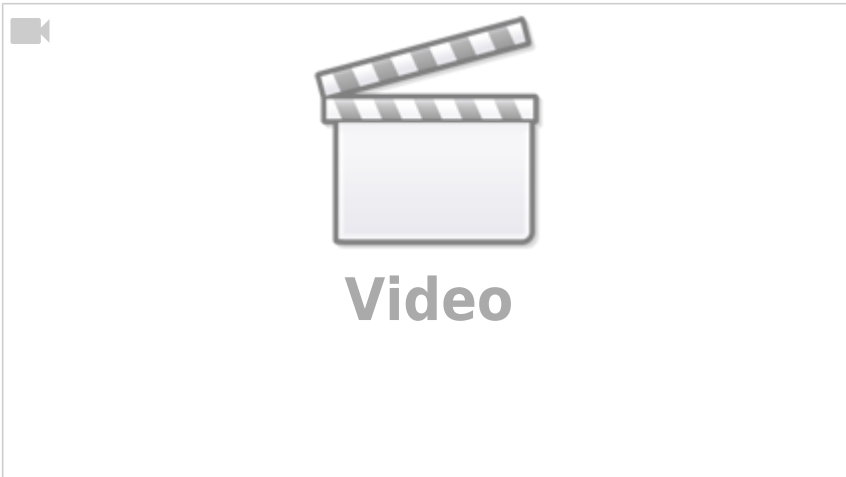

Exercise 2.7.3 Circuit Simplification Exercise IV (in German)



Exercise 2.7.4 Circuit Simplification Exercise V (in German)



Exercise 2.7.5 Circuit Simplification Exercise VI (in German)



Exercise 2.7.7 Simplifying Circuits (exam task, about 8% of a 60-minute exam, WS2020)

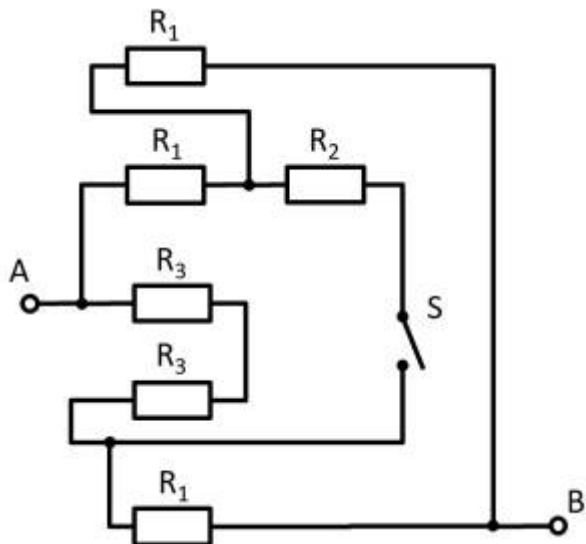

Given is the adjoining circuit with

$$R_1 = 10 \text{ } \Omega$$

$$R_2 = 20 \text{ } \Omega$$

$$R_3 = 5 \text{ } \Omega$$

and the switch S .

1. Determine the total resistance R_{eq} between A and B by summing the resistances with the switch S open.

Tips for solving

- How can the circuit be better represented or pulled apart?
- The switch should be replaced by an open wire in this case.

Solution

First of all, it is a good idea to reshape the circuit so that the actual structure becomes visible. For this purpose, the individual branches can be highlighted in color and interpreted as a “conductive rubber band”.

This results in:

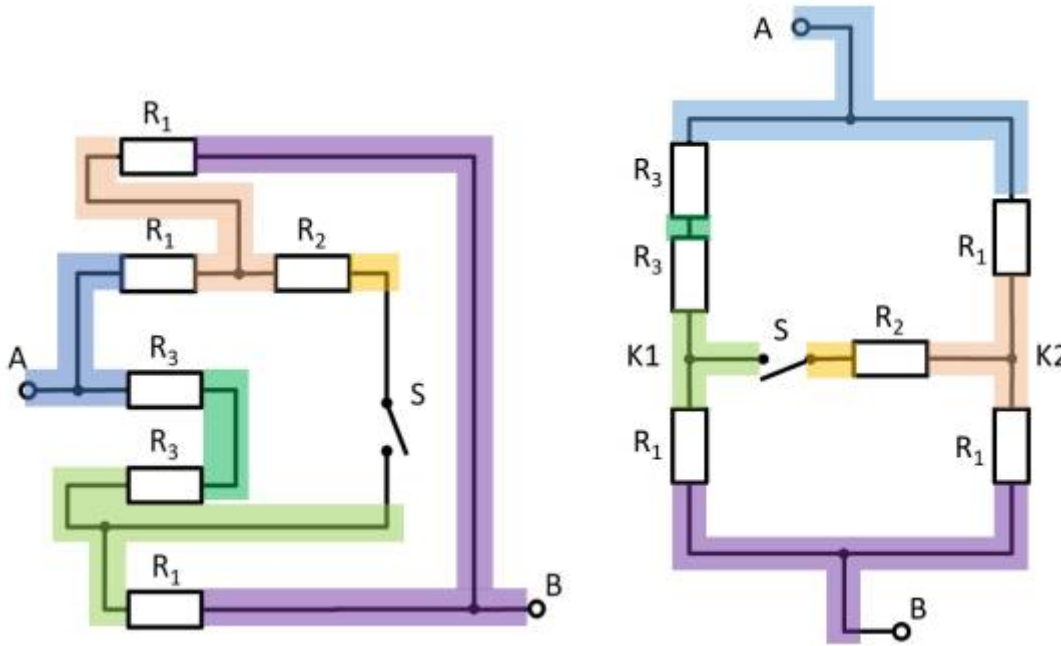

Thus R_3 and R_3 can be combined to $R_{33} = 2 \cdot R_3 = R_1$, yielding a left and a right voltage divider.

Now it is visible that in the left and right voltage divider, the same potential is at the respective branch, or at the node K1 (green) and K2 (pink).

Thus, the total resistance can be calculated as $R_{\text{req}} = (2 \cdot R_1) \parallel (2 \cdot R_1)$. However, by symmetry, nodes K1 and K2 can also be short-circuited. Thus, $R_{\text{req}} = 2 \cdot \left(R_1 \parallel R_1 \right)$ also holds.

Final result

$$\begin{aligned} R_{\text{req}} &= 2 \cdot \left(10 \sim\Omega \parallel 10 \sim\Omega \right) = 10 \sim\Omega \end{aligned}$$

2. What is the total resistance when switch S is closed?

Final result

Due to symmetry, the potentials at K1 and K2 are equal. Thus, no current flows across resistor R_2 even when the switch is closed. So the resistance remains the same.

Exercise 2.7.8: Simplifying Circuits II (written exam task, approx 8% of a 60-minute written exam, WS2020)

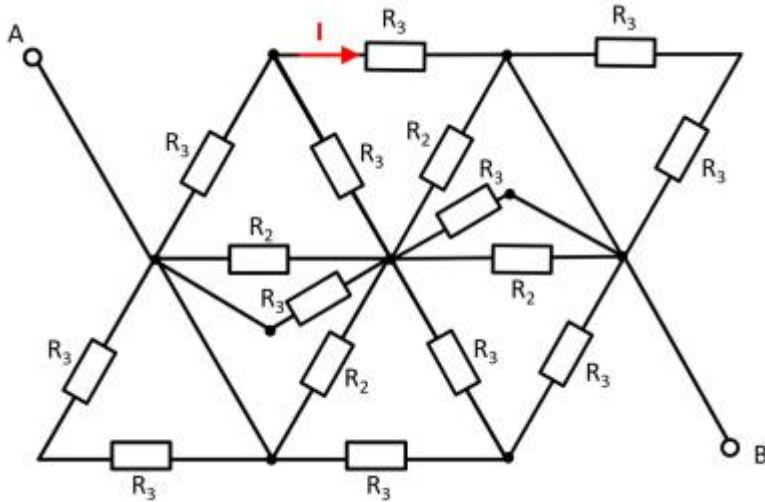

Given is the adjoining circuit with
 $R_1 = 5 \Omega$
 $R_2 = 10 \Omega$
 $R_3 = 20 \Omega$

1. Determine the equivalent resistance R_{eq} between A and B by summing the resistances.

Tips for solving

- How can the circuit be better represented or pulled apart?
- Switches (when used) should be replaced by an open or closed circuit.
- Does this result in equal potentials at different nodes that can be cleverly used?

Solution

First of all, it is a good idea to reshape the circuit so that the actual structure becomes visible. For this purpose, the individual branches can be highlighted in color and interpreted as a “conductive rubber band”.

It can be seen that the two resistors R_3 at the top left and bottom right are each shorted. The result is thus:

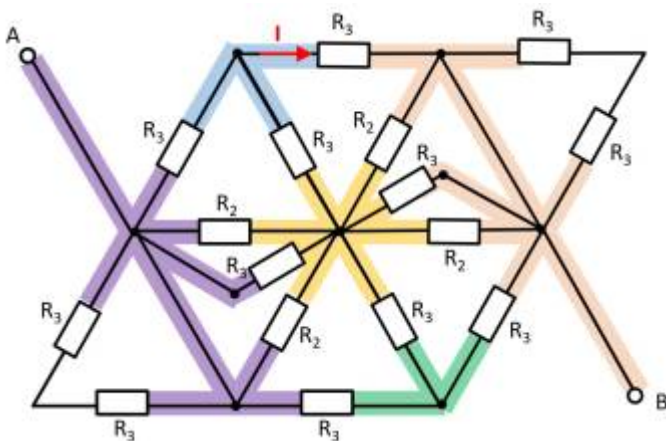

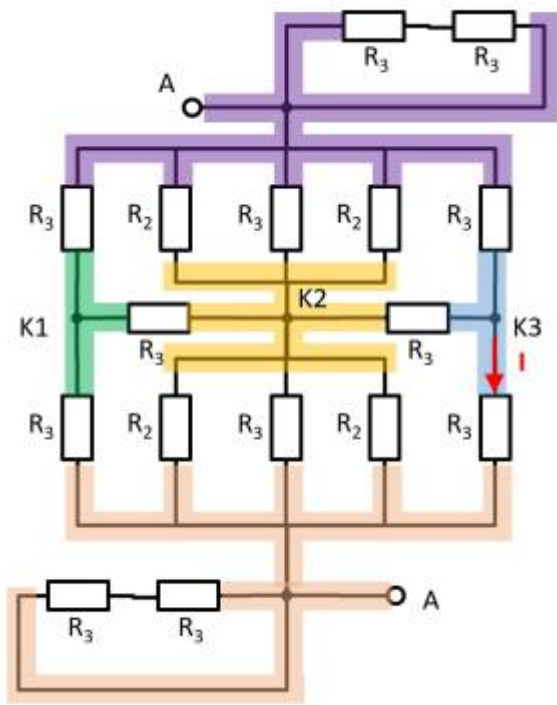

Here it helps to consider the potential of the nodes K1, K2, and K3. For K2, the resistances $R_2 \parallel R_3 \parallel R_2$ must be combined at the top and bottom. Thus, the same resistance values at the top and bottom result. Also at the nodes K1 and K2 the same resistance values at the top and at the bottom result. With the same ratios of the resistances at K1, K2, and K3 respectively, it can be concluded that no current flows across the resistors R_3 between K1 and K2 or K2 and K3. Thus, these do not contribute to the total resistance. In such a case, a short circuit or an open line can be freely chosen between the relevant nodes for the calculation. In the following, an open line is chosen. Additionally, the parallel strings can be reordered.

Fig. 11: Simulation

This results in:

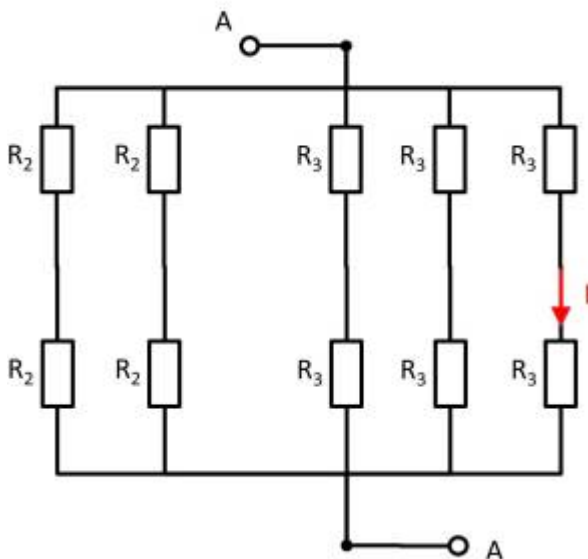

$$\begin{aligned}
 R_{\text{eq}} &= \left(\left(2 \cdot R_2 \right) \parallel \left(2 \cdot R_2 \right) \right) \parallel \left(\left(2 \cdot R_3 \right) \parallel \left(2 \cdot R_3 \right) \parallel \left(2 \cdot R_3 \right) \right) \\
 R_{\text{eq}} &= R_2 \parallel \left(R_3 \parallel \left(2 \cdot R_3 \right) \right) \\
 R_{\text{eq}} &= R_2 \parallel \frac{R_3 \cdot 2 R_3}{R_3 + 2 R_3} \\
 R_{\text{eq}} &= \frac{R_2 \cdot \frac{2}{3} R_3}{R_2 + \frac{2}{3} R_3} \\
 R_{\text{eq}} &= \frac{R_2 \cdot R_3}{\frac{3}{2} R_2 + R_3}
 \end{aligned}$$

Final result

$$R_{\text{eq}} = \frac{10 \cdot 20}{\frac{3}{2} \cdot 10 + 20} = 5.7143 \Omega \rightarrow 5.7 \Omega$$

2. Now let the voltage from A to B be: $U_{AB} = U_0 = 20 \text{ V}$. What is the current I ?

Solution

The partial current I is obtained directly from the voltage U_0 :

$$I = \frac{U_0}{2 \cdot R_3}$$

Final result

$$I = \frac{20 \text{ V}}{2 \cdot 20 \Omega} = 0.5 \text{ A}$$

Exercise 2.7.9 - Variation: Simplifying Circuits II (written exam task, approx 8% of a 60-minute written exam, WS2020)

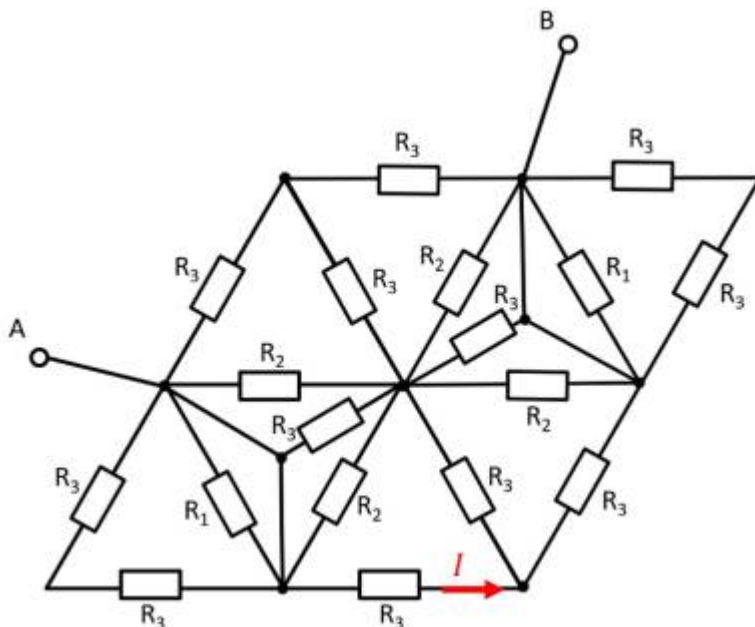

Given is the adjoining circuit with

$$R_1 = 10 \Omega$$

$$R_2 = 20 \Omega$$

$$R_3 = 5 \Omega$$

1. Determine the equivalent resistance R_{eq} between A and B by summing the

resistances.

Final result

$$R_{ges} = \frac{20 \Omega \cdot 5 \Omega}{\frac{3}{2} \cdot 20 \Omega + 5 \Omega} = 2.858 \Omega \rightarrow 2.9 \Omega$$

2. Now let the voltage from A to B be: $U_{AB} = U_0 = 10 \text{ V}$. What is the current I ?

Final result

$$I = \frac{10 \text{ V}}{2 \cdot 5 \Omega} = 1 \text{ A}$$

Exercise 2.7.10 - Variation: Simplifying Circuits III (written exam task, approx 8% of a 60-minute written exam, WS2020)

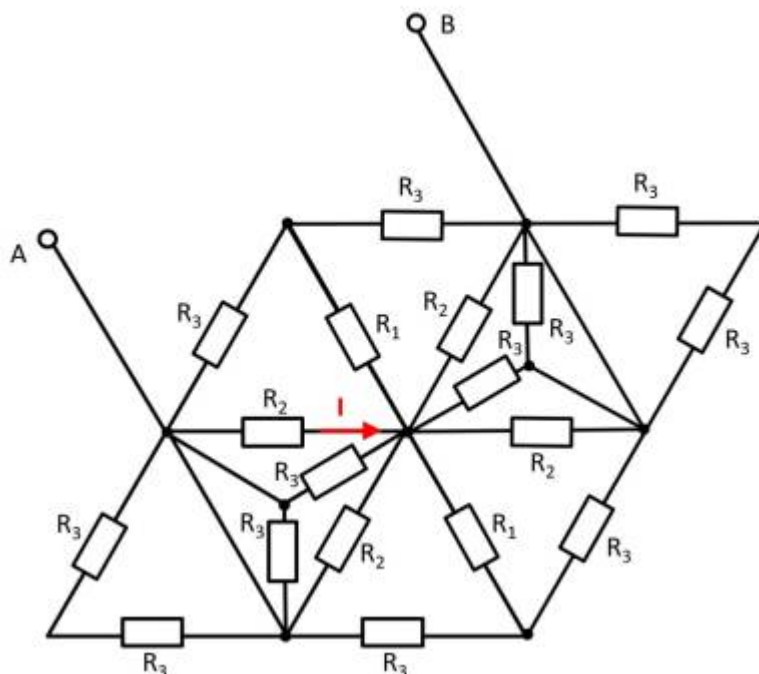

Given is the adjoining circuit with

$$R_1 = 5 \Omega$$

$$R_2 = 20 \Omega$$

$$R_3 = 10 \Omega$$

1. Determine the equivalent resistance R_{eq} between A and B by summing the resistances.

2. Now let the voltage from A to B be: $U_{AB} = U_0 = 30 \text{ V}$. What is the current I ?

Embedded resources

Why are voltage dividers important? (a cutout from 0:00 to 10:56 from a full video of EEVblog, starting from 17:00 there is also a nice example for troubles with voltage dividers.)

Summary (take-away)

• **Series:** R_1 adds, R_2 adds.

• **Voltage divider:** $U_1 = \frac{R_2}{R_1 + R_2} U$ (unloaded); with load, U_1 decreases per $\frac{U_1}{U} = \frac{1}{1 + \frac{R_2}{R_L} + \frac{R_2}{R_1}}$.

• **Current divider:** branch currents split in proportion to **conductances**.

• **Bridge:** balance when products of opposite arms are equal.

• **Δ -Y / Y- Δ :** unlocks reductions when pure series/parallel isn't available.

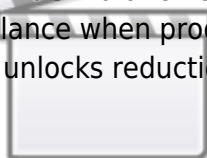

Video

All formulas consistent with the colleague's slides (ee1spo4.pdf ch.2).

Preparation for next block

Skim **real sources & two-terminal networks** (internal resistance, Thevenin/Norton). Bring questions about **loaded dividers** and **efficiency vs. power transfer** (ties into utilization/impedance matching).

From: <https://wiki.mexle.org/> - MEXLE Wiki

Permanent link: https://wiki.mexle.org/electrical_engineering_and_electronics_1/block05?rev=1761323347

Last update: 2025/10/24 18:29

