

# Block 18 — Magnetic Flux and Induction

## Student Group

First Name	Surname	Matrikel Nr.

## Table of Contents

<b>Block 18 — Magnetic Circuits and Inductance</b> .....	2
<i>Learning objectives</i> .....	2
<i>Preparation at Home</i> .....	2
<i>90-minute plan</i> .....	2
<i>Conceptual overview</i> .....	2
<i>Core content</i> .....	2
<i>Common pitfalls</i> .....	2
<i>Exercises</i> .....	3
Exercise E10 Magnetic Circuit (written test, approx. 7 % of a 120-minute written test, SS2022) .....	3
Exercise E10 Magnetic Circuit (written test, approx. 9 % of a 120-minute written test, SS2024) .....	4
<i>Embedded resources</i> .....	6

# Block 18 — Magnetic Circuits and Inductance

## Learning objectives

After this 90-minute block, you can

- ...

## Preparation at Home

Well, again

- read through the present chapter and write down anything you did not understand.
- Also here, there are some clips for more clarification under 'Embedded resources' (check the text above/below, sometimes only part of the clip is interesting).

For checking your understanding please do the following exercises:

- ...

## 90-minute plan

1. Warm-up (x min):
  1. ....
2. Core concepts & derivations (x min):
  1. ...
3. Practice (x min): ...
4. Wrap-up (x min): Summary box; common pitfalls checklist.

## Conceptual overview

1. ...

## Core content

...

## Common pitfalls

- ...

# Exercises

## Exercise E10 Magnetic Circuit

(written test, approx. 7 % of a 120-minute written test, SS2022)

The magnetic setup below shall be given. Draw the equivalent magnetic circuit to represent the setup fully. Name all the necessary magnetic resistances, fluxes, and voltages. The components shall be designed in such a way, that the magnetic resistance is constant in it.

Formulas are not necessary.

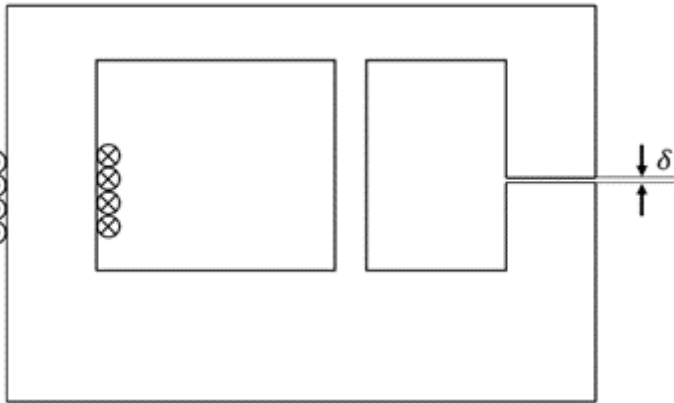

Path

Watch for parts of the magnetic circuit, where the width and material are constant. These parts represent the magnetic resistors which have to be calculated individually. Be aware, that every junction creates a branch with a new resistor, like for an electrical circuit - there must be a node on each "diversion".

$$R_m = \frac{1}{\mu_0 \mu_r} \frac{l}{w \cdot h}$$

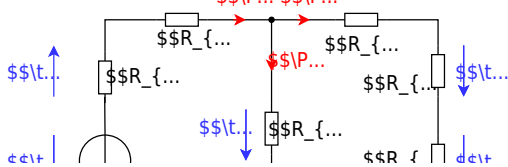



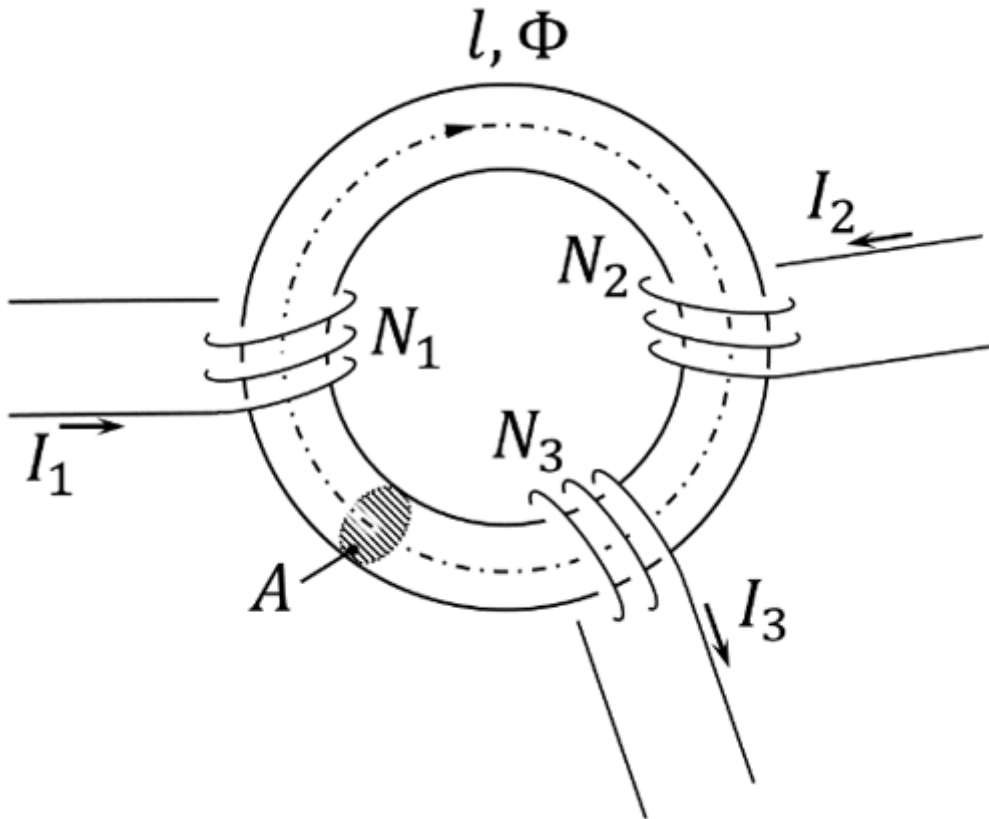

On the core, there are three coils with:

- Coil 1:  $N_1 = 1200$ ,  $I_1 = 100 \text{ mA}$
- Coil 2:  $N_2 = 33$ ,  $I_2 = 3 \text{ A}$
- Coil 3:  $N_3 = 270$ ,  $I_3 = 0.3 \text{ A}$

Refer to the drawing for the direction of the windings, current, and flux!

1. Draw the equivalent magnetic circuit that fully represents the setup. Name all the necessary magnetic resistances, fluxes, and voltages.

Result

- Since the material, and diameter of the core is constant, one can directly simplify the magnetic resistor into a single  $R \text{ m}$ .
- For the orientation of the magnetic voltages  $\theta_1$ ,  $\theta_2$ , and  $\theta_3$ , the orientation of the coils and the direction of the current has to be taken into account by the right-hand rule.
- There is only one flux  $\Phi$
- The magnetic voltages are antiparallel to the flux for sources and parallel for the load.

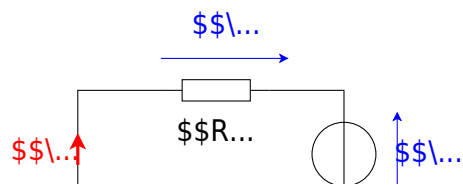

## Embedded resources

Explanation (video): ...

From:

<https://wiki.mexle.org/> - MEXLE Wiki

Permanent link:

[https://wiki.mexle.org/electrical\\_engineering\\_and\\_electronics\\_1/block18?rev=1763838426](https://wiki.mexle.org/electrical_engineering_and_electronics_1/block18?rev=1763838426)

Last update: **2025/11/22 20:07**

