

Block 18 — Magnetic Flux and Induction

Student Group

First Name	Surname	Matrikel Nr.

Table of Contents

Block 18 — Magnetic Circuits and Inductance	2
<i>Learning objectives</i>	2
<i>Preparation at Home</i>	2
<i>90-minute plan</i>	2
<i>Conceptual overview</i>	2
<i>Core content</i>	2
Flux	3
Linked Flux	7
Notice:	9
Basics for Linear Magnetic Circuits	9
Current-carrying Coil	11
Ferrite Core	11
Airgap	11
Reluctance - the magnetic Resistance	11
<i>Common pitfalls</i>	13
<i>Exercises</i>	13
Exercise E10 Magnetic Circuit (written test, approx. 7 % of a 120-minute written test, SS2022)	13
Exercise E10 Magnetic Circuit (written test, approx. 9 % of a 120-minute written test, SS2024)	14
Exercise E1 Cylindrical Coil (written test, approx. 6 % of a 120-minute written test, SS2021)	16
<i>Embedded resources</i>	17

Block 18 — Magnetic Circuits and Inductance

Learning objectives

After this 90-minute block, you can

- ...

Preparation at Home

Well, again

- read through the present chapter and write down anything you did not understand.
- Also here, there are some clips for more clarification under 'Embedded resources' (check the text above/below, sometimes only part of the clip is interesting).

For checking your understanding please do the following exercises:

- ...

90-minute plan

1. Warm-up (x min):
 1.
2. Core concepts & derivations (x min):
 1. ...
3. Practice (x min): ...
4. Wrap-up (x min): Summary box; common pitfalls checklist.

Conceptual overview

1. ...

Core content

For this and the following chapter the online Book 'DC Electrical Circuit Analysis - A Practical Approach' is strongly recommended as a reference. In detail this is chapter [10.3 Magnetic Circuits](#)

In the previous chapters, we got accustomed to the magnetic field. During this path, some similarities

from the magnetic field to the electric circuit appeared (see [figure 1](#)).

Fig. 1: Similarities magnetic Circuit vs electric Circuit

In this chapter, we will investigate how far we have come with such an analogy and where it can be practically applied.

Flux

The magnetic flux is a measurement of the amount of magnetic field lines through a given surface area, as seen in [figure 3](#). The magnetic flux is the amount of magnetic field lines cutting through a surface area defined by the surface vector \vec{A} . If the angle between the $\vec{A} = A \cdot \vec{n}$ and magnetic field vector \vec{B} is parallel or antiparallel, as shown in the diagram, the absolute value of the magnetic flux is the highest possible value given the values of the area and the

magnetic field.

Fig. 3: The magnetic flux is the amount of magnetic field lines cutting through a surface area A .

This definition leads to a magnetic flux similar to the electric flux studied earlier:

$$\Phi_{\text{m}} = \iint_A \vec{B} \cdot d\vec{A}$$

figure 4 depicts a circuit and an arbitrary surface S that it bounds. Notice that S is an open surface: The planar area bounded by the circuit is not part of the surface, so it is not fully enclosing a volume.

Since the magnetic field is a source-free vortex field, the flux over a closed area is always zero:

$$\oint_A \vec{B} \cdot d\vec{A} = 0$$

By this, it can be shown that any open surface bounded by the circuit in question can be used to evaluate Φ_{m} . For example, Φ_{m} is the same for the various surfaces S , S_1 , S_2 of the figure.

Fig. 4: A circuit bounding an arbitrary open surface S .



The SI unit for magnetic flux is the Weber (Wb), $\Phi_{\text{m}} = [B] \cdot [A] = 1 \text{ T} \cdot \text{m}^2 = 1 \text{ Wb}$

If the B field is homogenous and B is perpendicular to the surface S , then the formula simplifies to:

$$\Phi_{\text{m}} = B \cdot A$$

Based on this definition, the magnetic field unit is occasionally expressed as Weber per square meter (Wb/m^2) instead of teslas. In many practical applications, the circuit of interest consists of a number N of tightly wound turns (similar to [figure 5](#)). Each turn experiences the same magnetic flux Φ_{m} . Therefore, the net magnetic flux through the circuits is N times the flux through one turn, and Faraday's law is written as

Linked Flux

When looking at the magnetic field in a coil multiple windings capture the passing flux, see [figure 9](#) (a). It can also be interpreted in such a way that the flux is going through the closed surface of the circuit multiple times (in picture (b)).

Fig. 9: Example for a linked Flux

The **linked flux** Ψ is defined as the resulting flux given by the sum of the partial fluxes of the closed circuit.

$$\Psi = \sum_{i=1}^n \Phi_i$$

For the case of a coil with N windings, this leads to:

$$\Psi = N \cdot \Phi$$

Notice:

When calculating the force, use the flux within the material (Φ).
When investigating effects in the coil, use the linked flux (Ψ).

Basics for Linear Magnetic Circuits

For the upcoming calculations, the following assumptions are made

1. The relationship between B and H is linear: $B = \mu \cdot H$
This is a good estimation when the magnetic field strength lays well below saturation
2. There is no stray field leaking out of the magnetic field conducting material.
3. The fields inside of airgaps are homogeneous. This is true for small air gaps.

One can calculate a lot of simple magnetic circuits when these assumptions are applied and focusing on the average field line are applied.

The average field line has the length of l

Fig. 3: Simplifications and Linearization

Two simple magnetic circuits are shown in [figure 2](#): They consist of

- a current-carrying coil
- a ferrite core
- an airgap (in picture (2) + (3)).

Fig. 2: A simple magnetic Circuit



These three parts will be investigated shortly:

Current-carrying Coil

For the magnetic circuit, the coil is parameterized only by:

- its number of windings N and
- the passing current i .

These parameters lead to the magnetic voltage $\theta = N \cdot i$.

Ferrite Core

- The core is assumed to be made of ferromagnetic material.
- Therefore, the relative permeability in the core is much larger than in air ($\mu_{r,core} \gg 1$).
- The ferrite core is also filling the inside of the current-carrying coil.
- The ferrite core conducts the magnetic flux around the magnetic circuit (and by this: also to the airgap)

Airgap

- The air gap interrupts the ferrite core.
- The width of the air gap is small compared to the dimensions of the cross-section of the ferrite core.
- The field in the air gap can be used to generate (mechanical) effects within the air gap. An example of this can be the force onto a permanent magnet (see [figure 2 \(3\)](#)).

We also assume that the magnetic flux Φ remains constant along the ferrite core and in the air gap, so $\Phi_{\text{airgap}} = \Phi_{\text{core}} = \text{const.}$

Reluctance - the magnetic Resistance

Let's have a look at the simplest situation:

Fig. 1: the simple magnetic circuit

What do we know about this circuit?

1. The length of the average field line is l .
The cross-sectional area shall be constant: $A = \text{const.}$
2. magnetic voltage: $\oint \vec{H} \cdot d\vec{l} = NI$
3. magnetic flux: $\Phi = \int \vec{B} \cdot d\vec{A}$
4. relationship between the two fields: $\vec{B} = \mu \vec{H}$

This can now be combined. Let us start with (3) in (2) and then take this result to divide (1) by it:

$$\oint \vec{H} \cdot d\vec{l} = NI \quad \left\{ \frac{\oint \vec{H} \cdot d\vec{l}}{\Phi} \right\} = \left\{ \frac{NI}{\int \vec{B} \cdot d\vec{A}} \right\} = \left\{ \frac{NI}{\int \mu \vec{H} \cdot d\vec{A}} \right\}$$

Hmm.. what have we done here? We divided the voltage by the flux, similar to $\frac{U}{I}$ and we got something only depending on the dimensions and material.

The relationship $B = \mu \cdot H$, and $\mu_{\text{core}} \gg \mu_{\text{airgap}}$ lead to the fact that the H -Field must be much stronger within the airgap (figure ## (3)).

Fig. ##: B- and H-field along the ferrite core

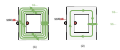

Common pitfalls

- ...

Exercises

Exercise E10 Magnetic Circuit

(written test, approx. 7 % of a 120-minute written test, SS2022)

The magnetic setup below shall be given. Draw the equivalent magnetic circuit to represent the setup fully. Name all the necessary magnetic resistances, fluxes, and voltages.

The components shall be designed in such a way, that the magnetic resistance is constant in it.

Formulas are not necessary.

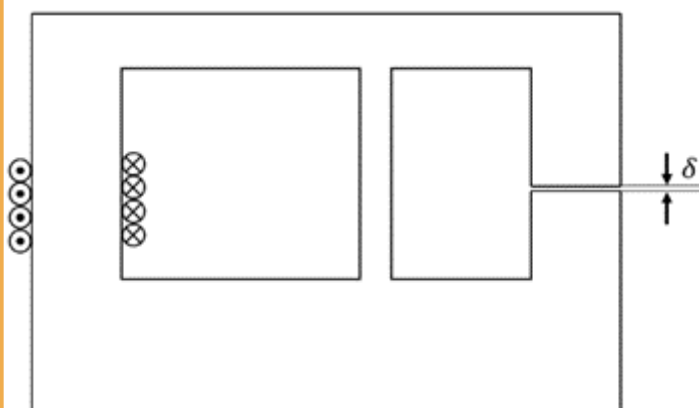

Path

To get the flux Φ , the Hopkinson's Law can be applied - similar to the Ohm's Law:

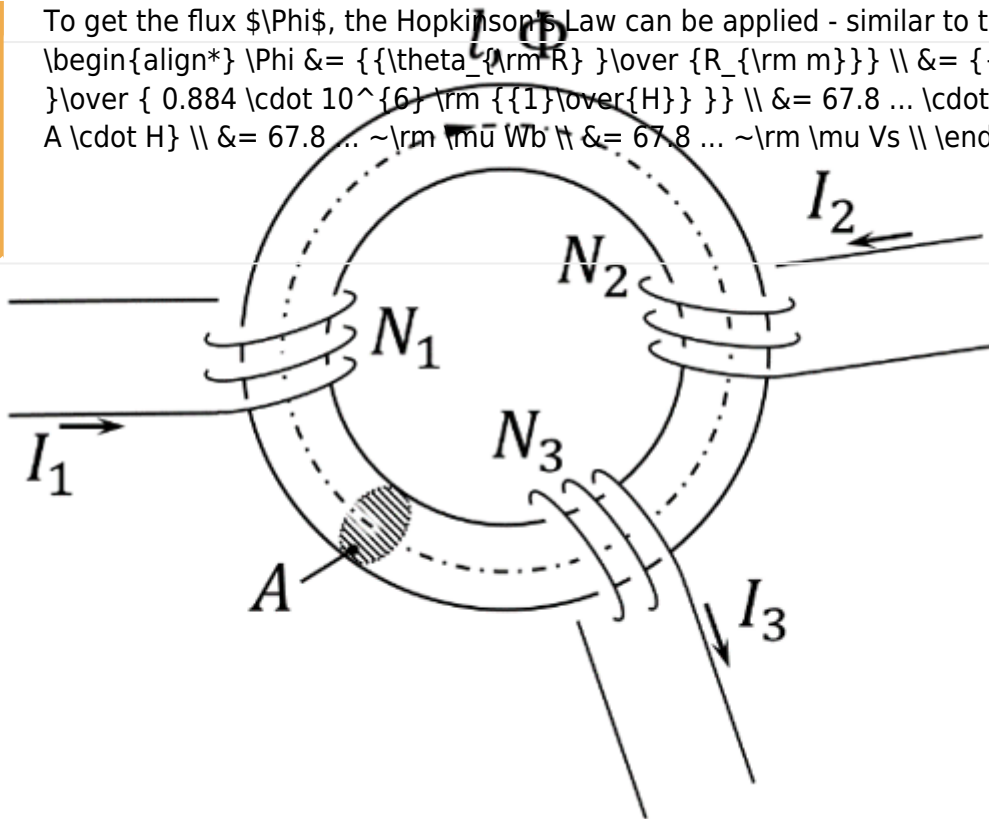
$$\Phi = \frac{\sum \theta_{\text{arm}}}{R_{\text{m}}} = \frac{-60 \text{ A}}{0.884 \cdot 10^6 \frac{\text{m}}{\text{H}}} = 67.8 \cdot 10^{-6} \text{ A} \cdot \text{H} = 67.8 \cdot 10^{-6} \text{ Wb} = 67.8 \cdot 10^{-6} \text{ Vs}$$

On the core, there are three coils with:

- Coil 1: $N_1 = 1200$, $I_1 = 100 \text{ mA}$
- Coil 2: $N_2 = 33$, $I_2 = 3 \text{ A}$
- Coil 3: $N_3 = 270$, $I_3 = 0.3 \text{ A}$

Refer to the drawing for the direction of the windings, current, and flux!

1. Draw the equivalent magnetic circuit that fully represents the setup. Name all the necessary magnetic resistances, fluxes, and voltages.

Result

- Since the material, and diameter of the core is constant, one can directly simplify the magnetic resistor into a single R_{m} .
- For the orientation of the magnetic voltages θ_1 , θ_2 , and θ_3 , the orientation of the coils and the direction of the current has to be taken into account by the right-hand rule.
- There is only one flux Φ
- The magnetic voltages are antiparallel to the flux for sources and parallel for the load.

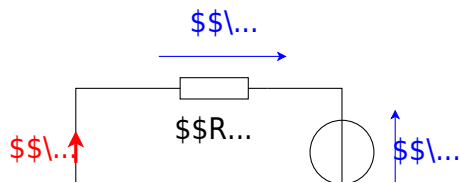

Exercise E1 Cylindrical Coil
(written test, approx. 6 % of a 120-minute written test, SS2021)

A) The magnetic flux (2 points) Information is given:

Result

- Length $l = 30 \text{ cm}$,

Path Winding diameter $d = 390 \text{ mm}$,

- Number of windings $N = 240$,
- Current through the inductor $I = 500 \text{ mA}$.

- Material inside: Air

$\mu_0 = 4\pi \cdot 10^{-7} \text{ Vs/Am}$

The magnetic field strength is $B = \mu_0 \mu_r H$:

The proportion of the magnetic voltage outside the coil can be neglected. Determine the following for the inside of the coil:

a) Determine the magnetic field strength (2 points)

$A = \pi r^2 = \pi \left(\frac{d}{2} \right)^2$

Path

Therefore: $\Phi = B \cdot \pi \left(\frac{d}{2} \right)^2$

Putting in the numbers:
$$\Phi = 0.0005026... \left\{ \frac{\text{Vs}}{\text{m}^2} \right\} \cdot \pi \left(\frac{0.39 \text{ m}}{2} \right)^2 \quad \&= 0.00006004... \text{ Vs}$$

General form:
$$\Phi = \left\{ \frac{N \cdot I}{l} \right\} = \left\{ \frac{w \cdot l}{l} \right\}$$

Putting in the numbers:
$$H = \frac{240 \cdot 0.5 \text{ A}}{0.3 \text{ m}}$$

Embedded resources

Explanation (video): ...

From:

<https://wiki.mexle.org/> - **MEXLE Wiki**

Permanent link:

https://wiki.mexle.org/electrical_engineering_and_electronics_1/block18?rev=1763926645

Last update: **2025/11/23 20:37**

