

Block 19 — Magnetic Circuits and Inductance

Student Group

First Name	Surname	Matrikel Nr.

Table of Contents

Block 19 — Magnetic Circuits and Inductance	2
<i>Learning objectives</i>	2
<i>Preparation at Home</i>	2
<i>90-minute plan</i>	2
<i>Conceptual overview</i>	2
<i>Core content</i>	2
Basics for Linear Magnetic Circuits	3
Current-carrying Coil	6
Ferrite Core	6
Airgap	6
Reluctance - the magnetic Resistance	6
Applications of Flux and Reluctance	9
Core with Airgap	9
Electric Magnet with three Legs	11
Notice:	12
<i>Common pitfalls</i>	13
<i>Exercises</i>	13
Exercise E1 Magnetic Circuit (written test, approx. 7 % of a 120-minute written test, SS2022)	13
Exercise E16 Magnetic Circuit (written test, approx. 9 % of a 120-minute written test, SS2024)	14
Exercise E7 Cylindrical Coil (written test, approx. 6 % of a 120-minute written test, SS2021)	16
<i>Embedded resources</i>	17

Block 19 — Magnetic Circuits and Inductance

Learning objectives

After this 90-minute block, you can

- ...

Preparation at Home

Well, again

- read through the present chapter and write down anything you did not understand.
- Also here, there are some clips for more clarification under 'Embedded resources' (check the text above/below, sometimes only part of the clip is interesting).

For checking your understanding please do the following exercises:

- ...

90-minute plan

1. Warm-up (x min):
 1.
2. Core concepts & derivations (x min):
 1. ...
3. Practice (x min): ...
4. Wrap-up (x min): Summary box; common pitfalls checklist.

Conceptual overview

1. ...

Core content

For this and the following chapter the online Book 'DC Electrical Circuit Analysis - A Practical Approach' is strongly recommended as a reference. In detail this is chapter [10.3 Magnetic Circuits](#)

In the previous chapters, we got accustomed to the magnetic field. During this path, some similarities

from the magnetic field to the electric circuit appeared (see [figure 1](#)).

Fig. 1: Similarities magnetic Circuit vs electric Circuit

In this chapter, we will investigate how far we have come with such an analogy and where it can be practically applied.

Basics for Linear Magnetic Circuits

For the upcoming calculations, the following assumptions are made

1. The relationship between B and H is linear: $B = \mu \cdot H$
This is a good estimation when the magnetic field strength lays well below saturation
2. There is no stray field leaking out of the magnetic field conducting material.

3. The fields inside of airgaps are homogeneous. This is true for small air gaps.

One can calculate a lot of simple magnetic circuits when these assumptions are applied and focusing on the average field line are applied.

The average field line has the length of l

Fig. 2: Simplifications and Linearization

Two simple magnetic circuits are shown in [figure 3](#): They consist of

- a current-carrying coil
- a ferrite core
- an airgap (in picture (2) + (3)).

Fig. 3: A simple magnetic Circuit

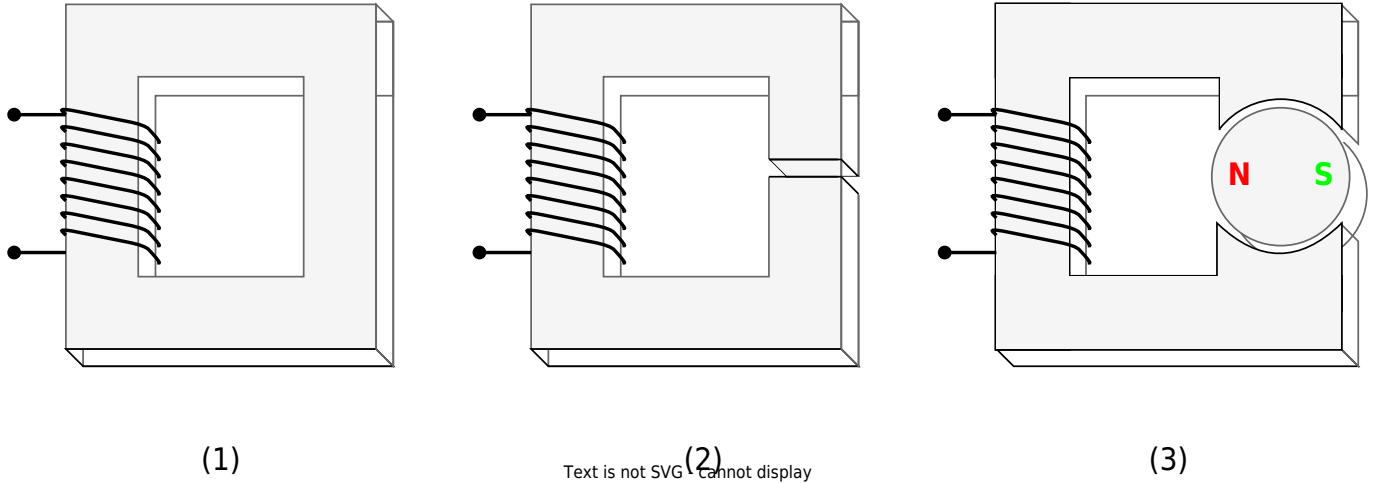

These three parts will be investigated shortly:

Current-carrying Coil

For the magnetic circuit, the coil is parameterized only by:

- its number of windings N and
- the passing current i .

These parameters lead to the magnetic voltage $\theta = N \cdot i$.

Ferrite Core

- The core is assumed to be made of ferromagnetic material.
- Therefore, the relative permeability in the core is much larger than in air ($\mu_{r, \text{core}} \gg 1$).
- The ferrite core is also filling the inside of the current-carrying coil.
- The ferrite core conducts the magnetic flux around the magnetic circuit (and by this: also to the airgap)

Airgap

- The air gap interrupts the ferrite core.
- The width of the air gap is small compared to the dimensions of the cross-section of the ferrite core.
- The field in the air gap can be used to generate (mechanical) effects within the air gap. An example of this can be the force onto a permanent magnet (see [figure 3 \(3\)](#)).

We also assume that the magnetic flux Φ remains constant along the ferrite core and in the air gap, so $\Phi_{\text{airgap}} = \Phi_{\text{core}} = \text{const.}$

Reluctance - the magnetic Resistance

Let's have a look at the simplest situation:

Fig. 1: the simple magnetic circuit

What do we know about this circuit?

1. The length of the average field line is l .
The cross-sectional area shall be constant: $A = \text{const.}$
2. magnetic voltage:
$$\theta = H \cdot l \tag{1}$$
3. magnetic flux:
$$\Phi = B \cdot A \tag{2}$$
4. relationship between the two fields:
$$B = \mu H \tag{3}$$

This can now be combined. Let us start with (3) in (2) and then take this result to divide (1) by it:

$$\Phi = \mu H \cdot A \quad \left\{ \frac{\theta}{\Phi} \right\} = \left\{ \frac{H \cdot l}{\mu H \cdot A} \right\} = \left\{ \frac{l}{\mu \cdot A} \right\}$$

Hmm.. what have we done here? We divided the voltage by the flux, similar to $\frac{U}{I}$ and

we got something only depending on the dimensions and material.

We might see some similarities here:

$$\begin{aligned} \frac{U}{I} = \rho \cdot \frac{l}{A} = R \quad \text{\textit{for the electric circuit}} \\ \end{aligned}$$

$$\begin{aligned} \boxed{\frac{\theta}{\Phi} = \frac{l}{\mu} \cdot \frac{I}{A} = R_m} \quad \text{\textit{for the magnetic circuit}} \\ \end{aligned}$$

The quantity R_m is called **reluctance or magnetic resistance**.

The unit of R_m is $[R_m] = \frac{\theta}{\Phi} = \frac{\text{Vs}}{\text{A}} = 1/H$

- The length l is given by the mean magnetic path length (= average field line length in the core).
- Kirchhoff's laws (mesh rule and nodal rule) can also be applied:
 - The sum of the magnetic fluxes Φ_i in into a node is: $\sum_i \Phi_i = 0$
 - The sum of the magnetic voltages θ_i along the average field line is: $\sum_i \theta_i = 0$
- The application of the lumped circuit model is based on multiple assumptions. In contrast to the simplification for the electric current and voltage the simplification for the flux and magnetic voltage is not as exact.

So, we got an equivalent magnetic circuit:

Applications of Flux and Reluctance

Core with Airgap

Another common situation is to have a air gap separating the iron core.

The width of air gaps are commonly given by δ .

The flux in the air gap and the core is the same, but the permeability μ differs strongly.

Fig. 5: Lumped Circuit Model for a simple magnetic Circuit

If it would be an electrical circuit, we would get for the source voltage U_S

$$\begin{aligned} U_S &= U_1 + U_2 \\ &= R_1 \cdot I + R_2 \cdot I \\ &= \rho_1 \frac{l_1}{A} \cdot I + \rho_2 \frac{l_2}{A} \cdot I \end{aligned}$$

The resulting formula for the magnetic voltage θ is similar:

$$\begin{aligned} \theta &= \theta_1 + \theta_2 \\ &= R_{m,1} \cdot \Phi + R_{m,2} \cdot \Phi \\ &= \frac{1}{\mu_0 \mu_{r,\text{core}}} \frac{l_{\text{core}}}{A} \cdot \Phi + \frac{1}{\mu_0 \mu_{r,\text{airgap}}} \frac{\Delta}{A} \cdot \Phi \end{aligned}$$

Additionally, the magnetic voltage θ is given by:
$$\theta = N \cdot I$$

Given the relationship $B = \mu \cdot H$, and $\mu_{\text{core}} \gg \mu_{\text{airgap}}$, we can conduct that H -Field must be much stronger within the airgap (figure 6 (3)).

Fig. 6: B- and H-field along the ferrite core

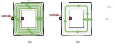

Electric Magnet with three Legs

Fig. 7: Lumped Circuit Model for a complex magnetic Circuit

Assuming that μ is constant, we get the following:

Fig. 8: lumped Circuit Model for a complex magnetic Circuit

+-----+ +-----+

With the reluctances:

$$\begin{aligned} R_{m,x} = \frac{1}{\mu_0 \mu_{r,x}} \frac{l_x}{A} \end{aligned}$$

Notice:

Sections with ...

- constant flux Φ
- constant cross-sectional area A
- constant material μ_r

... can be subsumed to a lumped magnetic resistans (reluctance)!

Common pitfalls

- ...

Exercises

Exercise E1 Magnetic Circuit (written test, approx. 7 % of a 120-minute written test, SS2022)

The magnetic setup below shall be given. Draw the equivalent magnetic circuit to represent the setup fully. Name all the necessary magnetic resistances, fluxes, and voltages. The components shall be designed in such a way, that the magnetic resistance is constant in it.

Formulas are not necessary.

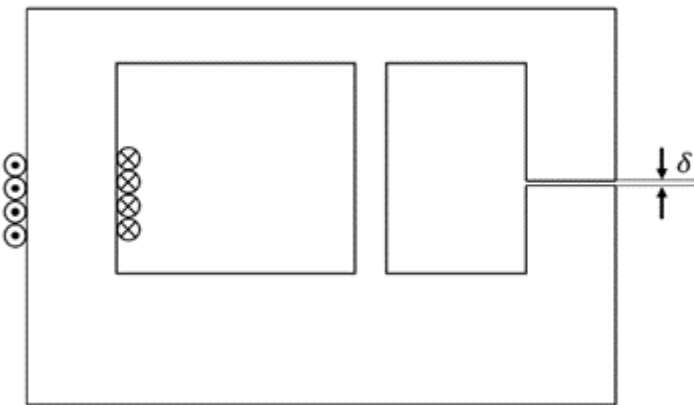

Path

Watch for parts of the magnetic circuit, where the width and material are constant. These parts represent the magnetic resistors which have to be calculated individually. Be aware, that every junction creates a branch with a new resistor, like for an electrical circuit - there must be a node on each "diversion".

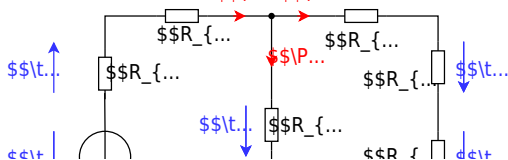
$$R_{\text{m}} = \frac{1}{\mu_0 \mu_{\text{r}}} \frac{l}{w \cdot h}$$

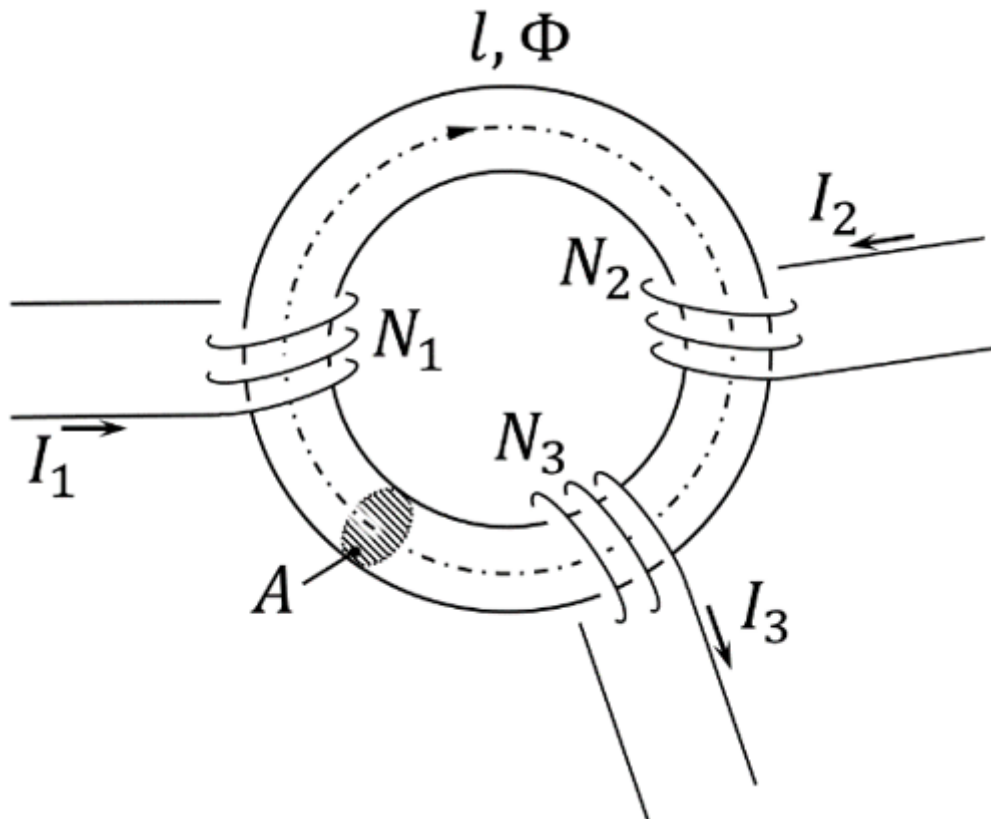

On the core, there are three coils with:

- Coil 1: $N_1 = 1200$, $I_1 = 100 \text{ mA}$
- Coil 2: $N_2 = 33$, $I_2 = 3 \text{ A}$
- Coil 3: $N_3 = 270$, $I_3 = 0.3 \text{ A}$

Refer to the drawing for the direction of the windings, current, and flux!

1. Draw the equivalent magnetic circuit that fully represents the setup. Name all the necessary magnetic resistances, fluxes, and voltages.

Result

- Since the material, and diameter of the core is constant, one can directly simplify the magnetic resistor into a single $R \text{ m}$.
- For the orientation of the magnetic voltages θ_1 , θ_2 , and θ_3 , the orientation of the coils and the direction of the current has to be taken into account by the right-hand rule.
- There is only one flux Φ
- The magnetic voltages are antiparallel to the flux for sources and parallel for the load.

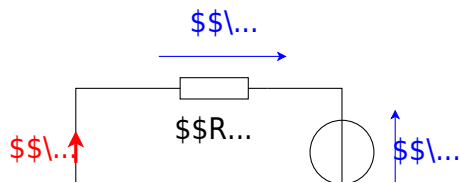

Exercise E7 Cylindrical Coil
(written test, approx. 6 % of a 120-minute written test, SS2021)

A) the magnetic flux (2 points) Information is given:

Result

- Length $l = 30 \text{ cm}$,

Path Winding diameter $d = 390 \text{ mm}$,

- Number of windings $N = 240$,
- Current through the inductor $I = 500 \text{ mA}$,

- Material inside: Air

$\mu_0 = 4\pi \cdot 10^{-7} \text{ Vs/Am}$

The magnetic field strength is $B = \mu_0 \mu_r H$:

The proportion of the magnetic voltage outside the coil can be neglected. Determine the following for the inside of the coil:

a) the magnetic field strength (2 points)

$A = \pi r^2 = \pi \left(\frac{d}{2} \right)^2$

Path

Therefore: $\Phi = B \cdot \pi \left(\frac{d}{2} \right)^2$

Putting in the numbers:
$$\Phi = 0.0005026... \left\{ \frac{V_s}{m^2} \right\} \cdot \pi \left(\frac{0.39 \text{ m}}{2} \right)^2 \quad \&= 0.00006004... \text{ m}^2$$

Therefore:
$$H = \frac{N \cdot I}{l} = \frac{w \cdot I}{l}$$

Putting in the numbers:
$$H = \frac{240 \cdot 0.5 \text{ A}}{0.3 \text{ m}}$$

Embedded resources

Explanation (video): ...

From:

<https://wiki.mexle.org/> - **MEXLE Wiki**

Permanent link:

https://wiki.mexle.org/electrical_engineering_and_electronics_1/block19?rev=1764697124

Last update: **2025/12/02 18:38**

