

# Block 21 – Op-Amp Basics

## Student Group

First Name	Surname	Matrikel Nr.

## Table of Contents

- Block 21 – Op-Amp Basics** ..... 2
- Learning objectives* ..... 2
- Preparation at Home* ..... 2
- 90-minute plan* ..... 2
- Conceptual overview* ..... 2
- Core content* ..... 2
- Introductory example ..... 2
- Circuit symbols and basic circuitry ..... 4
- Notice: opamp input ..... 7
- Basic Equation / Golden Rules ..... 8
- Remember: basic equation and golden rules ..... 9
- Power supply of the operational amplifier ..... 10
- Common pitfalls* ..... 11
- Exercises* ..... 11
- Worked examples ..... 11
- Embedded resources* ..... 11

# Block 21 — Op-Amp Basics

## Learning objectives

After this 90-minute block, you can

- ...

## Preparation at Home

Well, again

- read through the present chapter and write down anything you did not understand.
- Also here, there are some clips for more clarification under 'Embedded resources' (check the text above/below, sometimes only part of the clip is interesting).

For checking your understanding please do the following exercises:

- ...

## 90-minute plan

1. Warm-up (x min):
  1. ....
2. Core concepts & derivations (x min):
  1. ...
3. Practice (x min): ...
4. Wrap-up (x min): Summary box; common pitfalls checklist.

## Conceptual overview

1. ...

## Core content

### Introductory example

Acoustic amplifiers, such as those found in mobile phones, laptops, or hi-fi systems, often exhibit an unpleasant characteristic when heavily amplified: the previously undistorted signal is no longer passed on as usual, but **clatters**. It is distorted in such a way that it no longer

sounds pleasant.

For this purpose, you will find an acoustic example with pictures in [figure 1](#) and [figure 2](#) respectively. The bottom of each image shows the time course of the voltage output to a loudspeaker (x-axis: time, y-axis: frequency). The upper picture has three dimensions: It shows in color intensity which frequencies are used at which time. The frequencies in grey areas are not used. If a frequency is shown in red at one point in time, it has a relatively large amplitude.

Fig. 1: undistorted signal

[hallo.mp3](#)



Fig. 2: overdriven signal

[hallo\\_verzerrt.mp3](#)



It can be seen that the distorted signal has large amplitudes in the time course of the voltage as well as a wide distribution of frequencies (= a broad spectrum).

The high frequencies in particular can promote wear of the diaphragm in loudspeakers.

The signal distortion is due to the design of the amplifier, which can only output the maximum possible voltage and otherwise [clipping](#).

The structure of an acoustic amplifier is similar to that of a feedback operational amplifier, as seen in the simulation.

Acoustic amplifiers are usually constructed like operational amplifiers, which will be considered in the following chapters.

## Circuit symbols and basic circuitry

This chapter deals with operational amplifiers. One application for these are the measurement of voltages, currents, and resistances.

These values must be determined very precisely in some applications, for example for accurate temperature measurement. In this case, amplification of the measurement signals is useful and necessary.

This amplification is done by measuring amplifiers. Measuring amplifiers have to fulfill some characteristics.

Measurement amplifiers should ..

- ... **not have any feedback effect** on the measured variable.  
An operational amplifier should have the highest possible input resistance. This prevents the voltage to be amplified from collapsing.
- ... have a **high sensitivity**.  
An operational amplifier should have a large differential gain  $A_{\text{D}}$ .
- ... should show a **defined transmission behavior**, i.e. the output signal should be clearly related to the input signal.  
An operational amplifier concretely should show a linear relationship.
- ... show **good dynamic behavior**.  
The output signal of an operational amplifier should follow the input signal without any time delay.
- ... produce an **impressed output signal**.  
This means that the components at the amplifier output cannot change the output signal.  
An operational amplifier, specifically, should be able to maintain the desired output signal with the necessary current to do so.  
Since the current  $I_{\text{O}}$  can become very large (by electronic standards), this means that an operational amplifier must have a low output resistance  $R_{\text{O}} = \frac{U_{\text{O}}}{I_{\text{O}}}$ .

Fig. 3: Equivalent circuit diagram of an amplifier

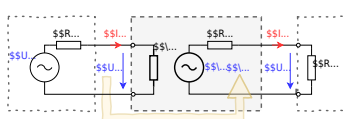

In general, an operational amplifier can be interpreted as a blackbox as in [figure 3](#). The real interior is quiet complex and needs an understanding of the transistor, as shown in the

### Architecture of the "simple" uA741.

Therefore, these chapter only focusses on the blackbox interpretation.

The circuit symbol of the amplifier is an isosceles triangle, at the apex of which the output signal originates and at the base of which the input signal enters.

In figure 4 you can see different circuit symbols:

Fig. 4: Circuit Symbols of Amplifiers

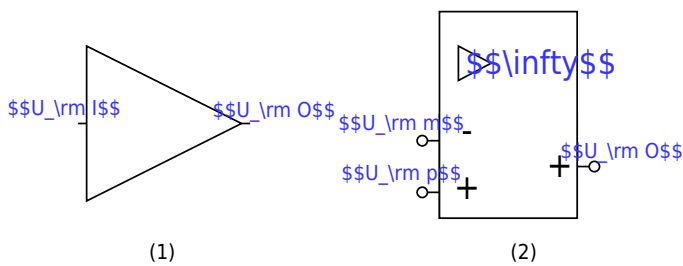

Source: [1]

Source: [2]

- Circuit symbol (1):  
In block diagrams (not to be confused with circuit diagrams, see [chapter 1](#)) this circuit symbol is used for general amplifiers. The input signal enters an input and exits through an input.
- Circuit symbol (2):  
According to DIN EN 60617, this circuit diagram is to be used for operational amplifiers. It indicates with the infinity sign the ideally infinitely high amplification. In the following this symbol is not used, because it is not used in all international circuits and tools.
- Circuit symbol (3):  
The circuit symbol (3) is the most commonly used symbol for an operational amplifier. On the left is the **inverting input** with voltage  $U_{\text{m}}$  (minus) and the **non-inverting input** with  $U_{\text{p}}$  (plus). The output with voltage  $U_{\text{O}}$  is shown on the right.
- Circuit symbol (4):  
The circuit symbol (4) is additionally drawn with the supply voltages  $U_{\text{sp}}$  (supply plus) and  $U_{\text{sm}}$  (supply minus). Power is provided from the supply for the output voltage of the operational amplifier.
- Circuit symbols (5) and (6):  
these symbols show **no** operational amplifier. These symbols show the NOT gate and the tri-state gate. Unfortunately, the representation of these digital components in various circuits is not unlike the operational amplifier.  
An example of this is the transceivers<sup>1)</sup> [SP3481](#) or [SP3485](#). If digital input values are considered, assuming that the circuit symbol does not represent an operational amplifier.

### Notice: opamp input

Fig. 5: Voltages at the operational amplifier



The inputs of the operational amplifier are designated as **inverting input**  $U_m$  and **non-inverting input**  $U_p$ .

The voltage  $U_D = U_p - U_m$  is called the differential voltage (see figure 5).

## Basic Equation / Golden Rules

The operational amplifier is a voltage amplifier. It simply measures on one side the voltage (like a voltmeter) and provides an amplified voltage on its output (like a voltage source).

Thus, for the ideal case, the input resistance must be infinite (like for a voltmeter) and the output resistance  $R_O = 0$  (like for a voltage source).

The figure 6 shows an ideal voltage amplifier.

This is characterized by the following properties:

- **Input resistance:**

The input side is drawn in the figure.

The resistance given here is the differential resistance  $R_D$  where the differential voltage  $U_D$  drops.

Therefore,  $R_D \rightarrow \infty$  is valid. Thus, the input currents  $I_p \rightarrow 0$  and  $I_m \rightarrow 0$ .

- **Output resistance, Basic equation:**

On the output side,  $R_O = 0$  gives that  $U_O = A_D \cdot U_D$ .

This is the basic equation of the amplifier circuit.

Ideally, the op-amp amplifies linearly, as indicated in the equation. Specifically, for a differential voltage of  $U_D$ , the output voltage is  $A_D \cdot U_D$ .

• **Voltage Gain:**

$A_D$  is very large.

Ideally, the following applies:  $A_D \rightarrow \infty$

Fig. 6: Operational amplifier equivalent circuit

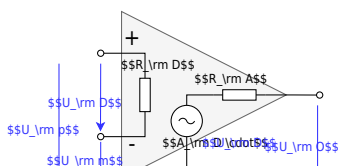

**Remember: basic equation and golden rules**

1. The output voltage depends on the differential voltage via the differential gain:  $U_O = A_D \cdot U_D$  This is the **basic equation** of the amplifier circuit.
2. The **golden rules** of the ideal amplifier are:
  1. The differential gain goes to infinity:  $A_D \rightarrow \infty$
  2. The input resistance goes to infinity:  $R_D \rightarrow \infty$
  3. The output resistance is 0:  $R_O = 0$

These rules have different limits in the real amplifier:

- Output voltage  $\mathbf{U_O = A_D \cdot U_D}$ :
  - The output voltage can only follow the input voltage as far as the power supply allows. In real operational amplifiers, only so-called **rail-to-rail** operational amplifiers can exploit the range down to a few  $100 \text{ mV}$  to  $U_S$ .

Other operational amplifiers have an **output limit**, which is  $\pm 2 \text{ V}$  below the supply voltage.

- If the supply voltages are not symmetrical ( $U_{\text{sm}} \neq -U_{\text{sp}}$ ), then the characteristic also shifts.
  - The ideal operational amplifier produces the same output voltage  $U_{\text{O}} = A_{\text{D}} \cdot U_{\text{D}}$  as long as  $U_{\text{D}} = U_{\text{p}} - U_{\text{m}}$  is the same. For the real operational amplifier with fixed  $A_{\text{D}}$ , output voltage  $U_{\text{O1}}$  for  $U_{\text{D1}} = 5 \text{ V} - 4.9 \text{ V}$  is different from  $U_{\text{O2}}$  for  $U_{\text{D1}} = 0.1 \text{ V} - 0 \text{ V}$ .
- **Differential gain  $A_{\text{D}}$ :**  
The differential gain is usually between  $A_{\text{D}} = 20'000 \dots 400'000$ .
  - **Input resistance  $R_{\text{D}}$ :**  
For real operational amplifiers, the input resistance  $R_{\text{I}} > 1 \text{ M}\Omega$  and the input current  $|I_{\text{p}}|$  or  $|I_{\text{m}}|$  is less than  $1 \text{ }\mu\text{A}$ .
  - **Output resistance  $R_{\text{O}}$ :**  
In real operational amplifiers, the output resistance  $R_{\text{O}}$  is usually a few  $\Omega$  and limited by a maximum current (in the range of a few tens of  $\text{mA}$  to a few  $\text{A}$ )

The op-amp in the simulation replicates a real op-amp in some respects: The voltage gain is  $A_{\text{D}} = 100'000$ .

The transfer characteristic  $U_{\text{O}}(U_{\text{D}})$  shows proportional behavior only when the output value is smaller in magnitude than the supply voltage  $|U_{\text{sp}}| = |U_{\text{sm}}| = 15 \text{ V}$  (not shown).

The modulation limits and the voltage gain can be changed in the simulation via “Edit component” (double click).

## Power supply of the operational amplifier

For the voltage supply of the operational amplifier, a distinction is made between unipolar and bipolar:

With the **bipolar voltage supply**, the same voltage levels but with different signs are applied to both supply terminals in terms of magnitude (figure 8 (1)).

This allows the output voltage  $U_{\text{O}}$  of the amplifier to point in either direction (figure 8 (2)). The power supply must be designed in such a way that it can provide both voltages. A differential voltage of  $U_{\text{D}} = 0$  also results in an output voltage of  $U_{\text{O}} = 0$ .

With the **unipolar power supply**, the negative supply terminal is connected to the ground (figure 8 (3)).

As a result, the output voltage  $U_{\text{O}}$  of the amplifier can only take on non-negative values (figure 8 (4)).

In this case, the supply can be provided by a single voltage source (e.g., a battery).

With a differential voltage of  $U_{\text{D}} = 0$ , the output voltage is  $U_{\text{O}} = \frac{1}{2} \cdot U_{\text{sp}}$ .

Fig. 8: unipolar and bipolar supply

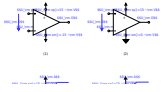

## Common pitfalls

- ...

## Exercises

## Worked examples

...

## Embedded resources

What is an operational amplifier?

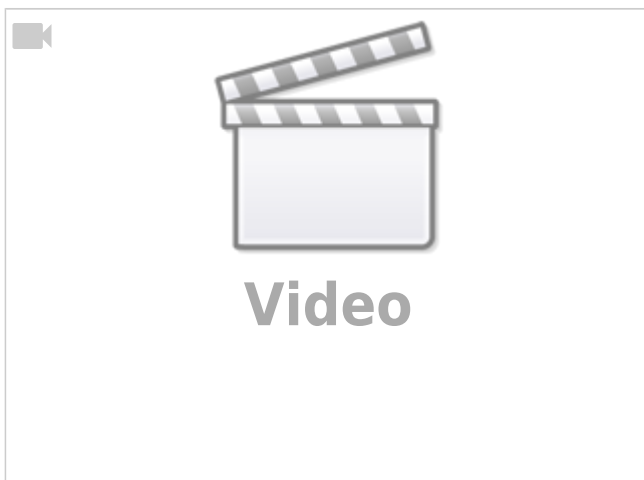

<sup>1)</sup> transmitter and receiver, meaning transmitter-receiver, or interface adapter

From:  
<https://wiki.mexle.org/> - **MEXLE Wiki**

Permanent link:  
[https://wiki.mexle.org/electrical\\_engineering\\_and\\_electronics\\_1/block21?rev=1765642061](https://wiki.mexle.org/electrical_engineering_and_electronics_1/block21?rev=1765642061)

Last update: **2025/12/13 17:07**

