

1 Preparation, Properties, and Proportions

Student Group

First Name	Surname	Matrikel Nr.

Table of Contents

- 1 Preparation, Properties, and Proportions** 4
- 1.1 Physical Proportions** 4
- Learning Objectives 4
- System of Units 4
- derived Quantities, SI Units, and Prefixes 5
- Physical Equations 6
- Quantity Equations 7
- normalized Quantity Equations 7
- Example for a quantity equation 7
- Letters for physical Quantities 8
- Exercises 9
- Exercise E1 Conversions: Battery 9
- Exercise E2 Conversions: Speed, Energy, and Power 9
- Exercise E3 Conversion: Vacuum Cleaner 10
- Exercise E4 Conversions: Video on Prefixes 10
- Exercise E5 Conversion: Energy Consumption 10
- Exercise E6 Conversions: Battery 11
- Exercise E7 Conversions: Speed, Energy, and Power 11
- Exercise E8 Conversion: Vacuum Cleaner 12
- Exercise E9 Conversions: Video on Prefixes 12
- Exercise E10 Conversion: Energy Consumption 12
- Exercise E11 Conversion: Energy, Power and Area 13
- Exercise E12 Conversion: Energy, Power and Area 13
- Learning Objectives** 14
- Preparation at Home** 14
- 90-minute plan** 14
- Conceptual overview** 14
- Core content** 15
- Time Course of the Charging and Discharging Process*** 18

Charging a capacitor at time $t=0$	19
Notice:	21
Discharging a capacitor at time $t=0$	22
Periodic switching operations	24
Energy stored in a Capacitor	25
Energy consideration of the capacitor	25
Energy Consideration on the Resistor	26
Consideration of total energy turnover	27
Common pitfalls	28
Exercises	28
Worked examples	28
Exercise 1.1 Capacitor charging/discharging practice Exercise	28
Exercise E 1.2 Capacitor charging/discharging	28
Exercise E1.3 Charge balance of two capacitors (educational exercise, not part of an exam)	
.....	30
Exercise E1.4 Machine-Vision Strobe Unit: Charging and Safe Discharge of a Flash Capacitor	
.....	31
Exercise E1.5 Sensor Input Buffer: Source, T-Network and Capacitor	35
Exercise E1.6 Hall-Sensor Calibration Coil: Short Air-Core Coil	38
Embedded resources	42
1.2 Introduction to the Structure of Matter	43
Learning Objectives	43
Elementary Charge	43
Conductivity of Matter	44
Conductor	44
Semiconductor	44
Isolator	44
Exercises	44
Exercise E13 Charges on a Ballon	45
Exercise E14 Charges on a Ballon	46
Exercise E15 Charges in Electroplating	46
Exercise E16 Charges in Electroplating	47
1.3 Effects of Electric Charges and Current	47
Learning Objectives	47
First Approximation to the el. Charge	47
Coulomb-Force	49
Note!	49
1.4 Charge and Current	50
Learning Objectives	50
Qualitative View	50
Definition of current	51
Note:	52
Direction of the Current	52
Definition of current direction (according to DIN5489)	53
Definition of electrodes (according to DIN5489)	53
Exercises	54
Exercise E17 Electron flow	54
Exercise E18 Determining the Current from Charge per Time	55
Exercise E19 Electron flow	56
Exercise E20 Determining the Current from Charge per Time	56
1.5 Voltage, Potential, and Energy	57

Learning Objectives	57
Energetic Approach	58
Comparison: Mechanics vs Electrics	59
Mechanical System	59
Electrical System	59
Note:	60
Definition of voltage	60
Voltage between two Points	60
Definition of the conventional direction of the voltage (according to DIN5489)	60
Exercises	60
Exercise E1.5.1 Direction of the voltage	60
1.6 Resistance and Conductance	62
Learning Objectives	62
Linearity of Resistors	63
Linear Resistors	63
Non-linear Resistors	63
Resistance as a Material Property	64
Note:	65
Temperature Dependence of Resistors	66
Note:	68
Outlook	70
Types of temperature-dependent Resistors	70
NTC Thermistor	71
PTC Thermistor	71
Resistor Packages	71
Exercises	72
Exercise 1.6.1 Pre-calculated example of resistivity	72
Exercise 1.6.2 Resistance of a pencil stroke	72
Exercise 1.6.3 Resistance of a cylindrical coil	72
Exercise 1.6.4 Resistance of a supply line	73
Exercise 1.6.5 Strain gauges	73
Exercise 1.6.6: Temperature-dependent resistance of a winding (written test, approx. 6 % of a 60-minute written test, WS2020)	73
1.7 Power and Efficiency	74
Learning Objectives	74
Determining the electrical Power in a DC Circuit	74
Nominal Quantities of ohmic Loads	77
Efficiency	77
Exercises	78
Exercise 1.7.1 Pre-calculated example of electrical power and energy	78
Exercise E1.7.2 Power	79
Exercise 1.7.3 Power loss and efficiency I	79
Exercise 1.7.4 Power loss and efficiency II	80
Exercise 1.7.5 PPTC	80
Further Reading	82

1 Preparation, Properties, and Proportions

1.1 Physical Proportions

Learning Objectives

By the end of this section, you will be able to:

1. know the fundamental physical quantities and the associated SI units.
2. know the most important prefixes. Be able to assign a power of ten to the respective abbreviation (G , M , k , d , c , m , μ , n).
3. insert given numerical values and units into an existing quantity equation. From this, you should be able to calculate the correct result using a calculator.
4. assign the Greek letters.
5. always calculate with numerical value and unit.
6. know that a related quantity equation is dimensionless!

A nice 10-minute intro into some of the main topics of this chapter

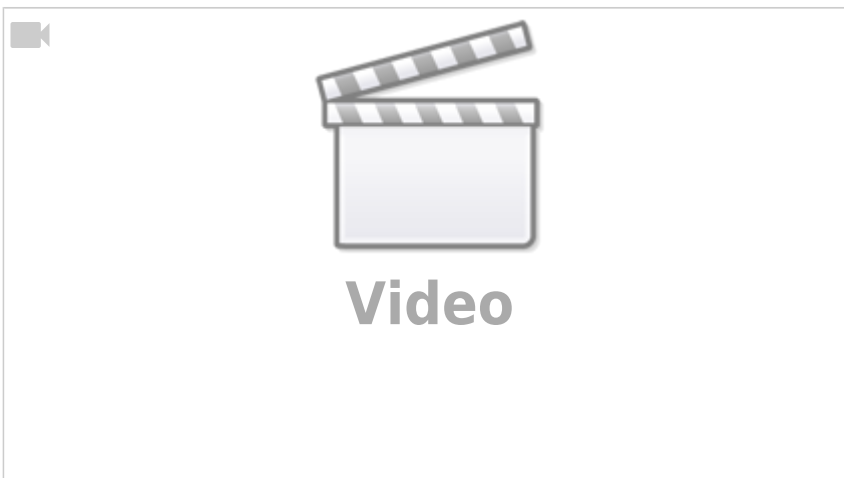

System of Units

Short presentation of the SI units

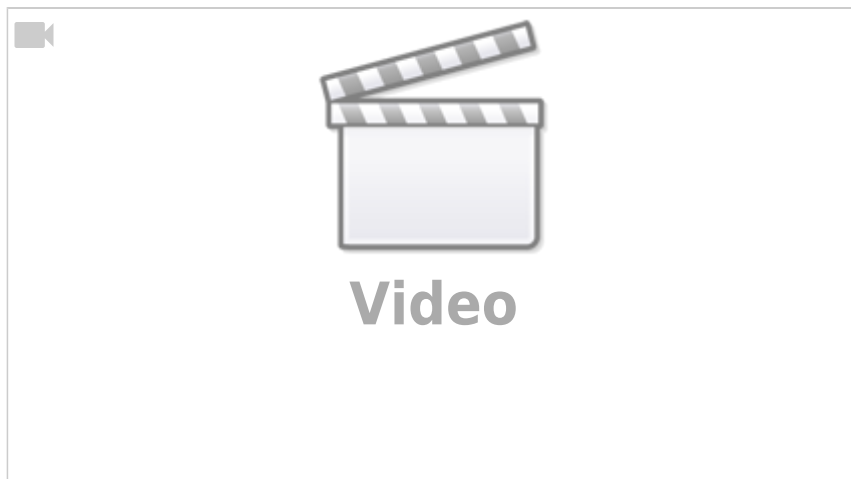

Base quantity	Name	Unit	Definition
Time	Second	$\{\mathrm{s}\}$	Oscillation of $\{\mathrm{Cs}\}$ -Atom
Length	Meter	$\{\mathrm{m}\}$	by $\{\mathrm{s}\}$ und speed of light
el. Current	Ampere	$\{\mathrm{A}\}$	by $\{\mathrm{s}\}$ and elementary charge
Mass	Kilogram	$\{\mathrm{kg}\}$	still by kg prototype
Temperature	Kelvin	$\{\mathrm{K}\}$	by triple point of water
amount of substance	Mol	$\{\mathrm{mol}\}$	via number of $\{^{12}\mathrm{C}\}$ nuclides
luminous intensity	Candela	$\{\mathrm{cd}\}$	via given radiant intensity

Tab. 1: SI-System

- For practical applications of physical laws of nature, **physical quantities** are put into mathematical relationships.
- There are basic quantities based on the SI system of units (French for *Système International d'Unités*), see below.
- In order to determine the basic quantities quantitatively (quantum = Latin for *how big*), **physical units** are defined, e.g. $\{\mathrm{metre}\}$ for length.
- In electrical engineering, the first three basic quantities (cf. [table 1](#)) are particularly important. Mass is important for the representation of energy and power.
- Each physical quantity is indicated by a product of **numerical value** and **unit**:
e.g. $I = 2 \sim \{\mathrm{A}\}$
 - This is the short form of $I = 2 \cdot 1 \sim \{\mathrm{A}\}$
 - I is the physical quantity, here: electric current strength
 - $\{I\} = 2$ is the numerical value
 - $\{I\} = 1 \sim \{\mathrm{A}\}$ is the (measurement) unit, here: $\{\mathrm{Ampere}\}$

derived Quantities, SI Units, and Prefixes

- Besides the basic quantities, there are also quantities derived from them, e.g. $1 \sim \left\{ \frac{\{\mathrm{m}\}}{\{\mathrm{s}\}} \right\}$.
- SI units should be preferred for calculations. These can be derived from the basic quantities **without a numerical factor**.
 - The pressure unit bar ($\{\mathrm{bar}\}$) is an SI unit.
 - BUT: The obsolete pressure unit "Standard atmosphere" ($= 1.013 \sim \{\mathrm{bar}\}$) is **not** an SI unit.
- To prevent the numerical value from becoming too large or too small, it is possible to replace a decimal factor with a prefix. These are listed in [table 2](#).

prefix	prefix symbol	meaning
Yotta	$\{\rm Y\}$	10^{24}
Zetta	$\{\rm Z\}$	10^{21}
Exa	$\{\rm E\}$	10^{18}
Peta	$\{\rm P\}$	10^{15}
Tera	$\{\rm T\}$	10^{12}
Giga	$\{\rm G\}$	10^9
Mega	$\{\rm M\}$	10^6
Kilo	$\{\rm k\}$	10^3
Hecto	$\{\rm h\}$	10^2
Deka	$\{\rm de\}$	10^1

Tab. 2: Prefixes I

prefix	prefix symbol	meaning
Deci	$\{\rm d\}$	10^{-1}
Centi	$\{\rm c\}$	10^{-2}
Milli	$\{\rm m\}$	10^{-3}
Micro	$\{\rm u\}$, μ	10^{-6}
Nano	$\{\rm n\}$	10^{-9}
Piko	$\{\rm p\}$	10^{-12}
Femto	$\{\rm f\}$	10^{-15}
Atto	$\{\rm a\}$	10^{-18}
Zeppto	$\{\rm z\}$	10^{-21}
Yocto	$\{\rm y\}$	10^{-24}

Tab. 2: Prefixes II

Importance of orders of magnitude in engineering (when the given examples in the video are unclear: we will get into this.)

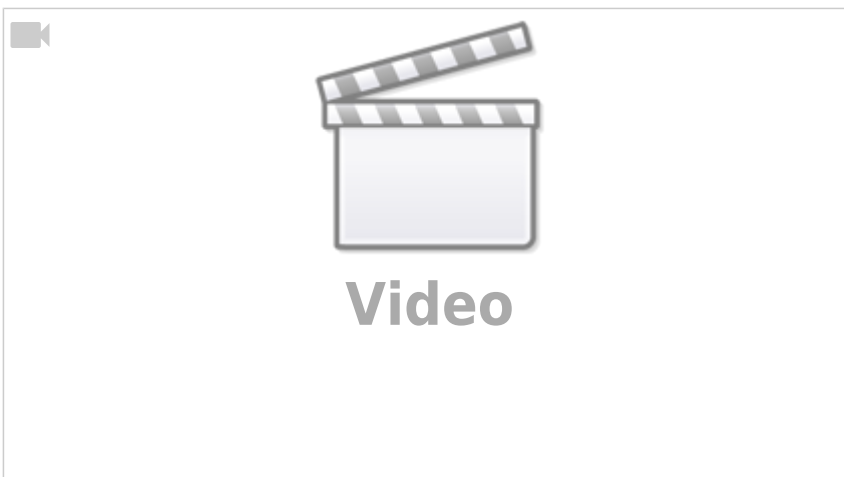

Physical Equations

- Physical equations allow a connection of physical quantities.
- There are two types of physical equations to distinguish (at least in German):
 - Quantity equations (in German: *Größengleichungen*)
 - Normalized quantity equations (also called related quantity equations, in German *normierte Größengleichungen*)

Quantity Equations

The vast majority of physical equations result in a physical unit that does not equal \$1\$.

Example: Force $F = m \cdot a$ with $[F] = 1 \sim \text{kg} \cdot \frac{\text{m}}{\text{s}^2}$

- A unit check should always be performed for quantity equations
- Quantity equations should generally be preferred

normalized Quantity Equations

In normalized quantity equations, the measured value or calculated value of a quantity equation is divided by a reference value. This results in a dimensionless quantity relative to the reference value.

Example: The efficiency $\eta = \frac{P_{\text{O}}}{P_{\text{I}}}$ is given as quotient between the outgoing power P_{O} and the incoming power P_{I} .

As a reference the following values are often used:

- Nominal values (maximum permissible value in continuous operation) or
- Maximum values (maximum value achievable in the short term)

For normalized quantity equations, the units should **always** cancel out.

Example for a quantity equation

Let a body with the mass $m = 100 \sim \text{kg}$ be given. The body is lifted by the height $s = 2 \sim \text{m}$.

What is the value of the needed work?

physical equation:

Work = Force \cdot displacement

$W = F \cdot s$ where $F = m \cdot g$

$W = m \cdot g \cdot s$ where $m = 100 \sim \text{kg}$, $s = 2 \sim \text{m}$ and $g = 9.81 \sim \frac{\text{m}}{\text{s}^2}$

$W = 100 \sim \text{kg} \cdot 9.81 \sim \frac{\text{m}}{\text{s}^2} \cdot 2 \sim \text{m}$

$W = 100 \cdot 9.81 \cdot 2 \text{ ; ; } \text{kg} \cdot \frac{\text{m}}{\text{s}^2}$

$\cdot \{m\}$
 $W = 1962 \cdot \left(\frac{m}{s^2} \right) \cdot m$
 $W = 1962 \cdot Nm = 1962 \cdot J$

Letters for physical Quantities

In physics and electrical engineering, the letters for physical quantities are often close to the English term.

Thus explains C for **C**apacity, Q for **Q**uantity and ϵ_0 for the **E**lectrical **F**ield **C**onstant. But, maybe you already know that C is used for the thermal capacity as well as for the electrical capacity. The Latin alphabet does not have enough letters to avoid conflicts for the scope of physics. For this reason, Greek letters are used for various physical quantities (see [table 4](#)).

Especially in electrical engineering, **upper/lower case letters** are used to distinguish between

- a constant (time-independent) quantity, e.g. the period T
- or a time-dependent quantity, e.g. the instantaneous voltage $u(t)$

Uppercase letters	Lowercase letters	Name	Application
A	α	Alpha	angles, linear temperature coefficient
B	β	Beta	angles, quadratic temperature coefficient, current gain
Γ	γ	Gamma	
Δ	δ	Delta	small deviation, length of a air gap
E	ϵ , ϵ_0	Epsilon	electrical field constant, permittivity
Z	ζ	Zeta	- (math function)
H	η	Eta	efficiency
Θ	θ , ϑ	Theta	temperature in Kelvin
I	ι	Iota	-
K	κ	Kappa	specific conductivity
Λ	λ	Lambda	- (wavelength)
M	μ	Mu	magnetic field constant, permeability
N	ν	Nu	-
Ξ	ξ	Xi	-
O	\omicron	Omicron	-
Π	π	Pi	math. product operator, math. constant
R	ρ , ϱ	Rho	specific resistivity
Σ	σ	Sigma	math. sum operator, alternatively for specific conductivity
T	τ	Tau	time constant
Υ	υ	Upsilon	-
Φ	ϕ , φ	Phi	magnetic flux, angle, potential
χ	χ	Chi	-

Uppercase letters	Lowercase letters	Name	Application
Ψ	ψ	Psi	linked magnetic flux
Ω	ω	Omega	unit of resistance, angular frequency

Tab. 4: greek letters

Exercises

Exercise E1 Conversions: Battery

2. How long is a car battery with 10 kWh of energy supplied by a 100 W power source? What time would it take to charge it?

Solution

$$t = 200'000 \text{ min}$$

There are additional losses:

$W = 10 \text{ kWh} = 10'000 \text{ Wh}$
 $t = \frac{W}{P} = \frac{10'000 \text{ Wh}}{100 \text{ W}} = 100 \text{ h} = 6'000 \text{ min}$
 provides, this leads to internal losses

- The internal resistance of the battery depends on the state of charge (SoC) of the battery.
- The wires also add additional losses to the system.

Exercise E2 Conversions: Speed, Energy, and Power

2. A car with a mass of 1500 kg is moving at a speed of 80 km/h. How much kinetic energy does it have? How much energy is required to accelerate it from 0 to 80 km/h? How much energy is required to maintain a speed of 80 km/h for 1 hour?

1. A vehicle speed of 80 km/h in m/s

Solution

fast Solution

$$\frac{80 \text{ km}}{3'600 \text{ s}} = 22.22 \frac{\text{m}}{\text{s}}$$

$$E_{kin} = \frac{1}{2} m v^2 = \frac{1}{2} \cdot 1500 \text{ kg} \cdot (22.22 \text{ m/s})^2 = 369'000 \text{ J} = 369 \text{ kJ}$$

$$E_{acc} = E_{kin} = 369 \text{ kJ}$$

$$P = \frac{E}{t} = \frac{369 \text{ kJ}}{1 \text{ h}} = 102.5 \text{ W}$$

$$E_{1h} = P \cdot t = 102.5 \text{ W} \cdot 3'600 \text{ s} = 369'000 \text{ J} = 369 \text{ kJ}$$

$$E_{1h} = 0.369 \text{ kWh}$$

Exercise E3 Conversion: Vacuum Cleaner

Your 18 V vacuum cleaner is equipped with a 4.0 Ah battery, it runs 15 min .

How much electrical power is consumed by the motor during this time on average?

Solution 288 W

$$W = 18\text{ V} \cdot 4.0\text{ Ah} = 72\text{ Wh} \\ 15\text{ min} = 0.25\text{ h} \\ P = \frac{W}{t} = \frac{72\text{ Wh}}{0.25\text{ h}} = 288\text{ W}$$

Exercise E4 Conversions: Video on Prefixes

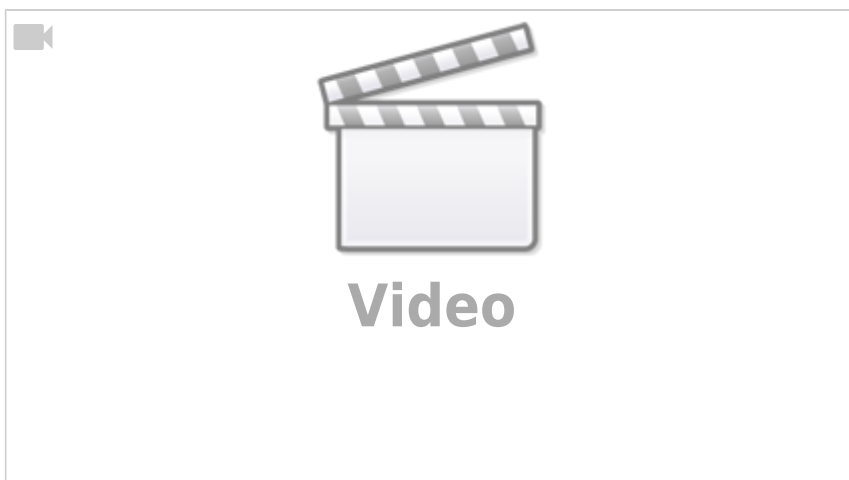

Exercise E5 Conversion: Energy Consumption

Convert the following values step by step:

Result

How much energy does an average household consume per day when consuming an average power of 500 W ?

How many chocolate bars (2000 kJ each) does this correspond to?

$$22\text{ chocolate bars}$$

Solution

Exercise E8 Conversion: Vacuum Cleaner

Your $18\text{~}\{\text{V}\}$ vacuum cleaner is equipped with a $4.0\text{~}\{\text{Ah}\}$ battery, it runs $15\text{~}\{\text{min}\}$.

How much electrical power is consumed by the motor during this time on average?

Solution $288\text{~}\{\text{W}\}$

$$\begin{aligned} W &= 18\text{~}\{\text{V}\} \cdot 4.0\text{~}\{\text{Ah}\} = 72\text{~}\{\text{Wh}\} \\ t &= 15\text{~}\{\text{min}\} = 0.25\text{~}\{\text{h}\} \\ P &= \frac{W}{t} = \frac{72\text{~}\{\text{Wh}\}}{0.25\text{~}\{\text{h}\}} = 288\text{~}\{\text{W}\} \end{aligned}$$

Exercise E9 Conversions: Video on Prefixes



Exercise E10 Conversion: Energy Consumption

Convert the following values step by step:

Result

How much energy does an average household consume per day when consuming an average power of $500\text{~}\{\text{W}\}$?

How many chocolate bars ($2'000\text{~}\{\text{kJ}\}$ each) does this correspond to?

$$22\text{~}\{\text{chocolate~bars}\}$$

Solution

$$\begin{aligned} W &= 500 \text{ Wh} \cdot 24 \text{ h} = 12000 \text{ Wh} = 43'200 \text{ kWs} \\ &= 43'200 \text{ kJ} \quad \text{\text{Or:}} \quad W = 0.5 \text{ kW} \cdot 24 \text{ h} = 12 \text{ kWh} = 43'200 \text{ kWs} \\ &= 43'200 \text{ kJ} \quad n_{\text{bars}} = \frac{43'200 \text{ kJ}}{2'000 \text{ kJ}} = 21.6 \text{ chocolate-bars} \end{aligned}$$

Exercise E11 Conversion: Energy, Power and Area

2. How many panels and strings (number of cells) are needed to power a car with an average 100 Wh per day and an usable battery capacity of 60 kWh. Solar panels produces per 1 m² in average in December 0.2 kWh/m². The car is driven 50 km per day. The size of a distinct solar module with 460 W_p (Watt peak) is 1.9 m × 1.1 m.

$$A = \frac{60 \text{ kWh} \cdot 24 \text{ h}}{0.2 \text{ kWh/m}^2} = 7200 \text{ m}^2$$

.. What is the average power consumption of the car per day?

$$\begin{aligned} A_{\text{panels}} &= \frac{A_{\text{car}} \cdot P_{\text{car}}}{P_{\text{panel}}} = \frac{100 \text{ Wh} \cdot 24 \text{ h}}{460 \text{ W}} = 5.22 \text{ panels} \\ \text{Solution (2)} & \text{ over } 2.0 \text{ m}^2 \text{ panel} \Rightarrow 19.04 \text{ panels} \end{aligned}$$

$$\begin{aligned} \frac{W}{l} &= \frac{16 \text{ kWh}}{100 \text{ km}} = 0.16 \text{ kWh/km} \\ W &= 50 \text{ km} \cdot 0.16 \text{ kWh/km} = 8 \text{ kWh} \end{aligned}$$

Exercise E12 Conversion: Energy, Power and Area

2. How many panels and strings (number of cells) are needed to power a car with an average 100 Wh per day and an usable battery capacity of 60 kWh. Solar panels produces per 1 m² in average in December 0.2 kWh/m². The car is driven 50 km per day. The size of a distinct solar module with 460 W_p (Watt peak) is 1.9 m × 1.1 m.

$$A = \frac{60 \text{ kWh} \cdot 24 \text{ h}}{0.2 \text{ kWh/m}^2} = 7200 \text{ m}^2$$

.. What is the average power consumption of the car per day?

$$\begin{aligned} A_{\text{panels}} &= \frac{A_{\text{car}} \cdot P_{\text{car}}}{P_{\text{panel}}} = \frac{100 \text{ Wh} \cdot 24 \text{ h}}{460 \text{ W}} = 5.22 \text{ panels} \\ \text{Solution (2)} & \text{ over } 2.0 \text{ m}^2 \text{ panel} \Rightarrow 19.04 \text{ panels} \end{aligned}$$

$$\begin{aligned} \frac{W}{l} &= \frac{16 \text{ kWh}}{100 \text{ km}} = 0.16 \text{ kWh/km} \\ W &= 50 \text{ km} \cdot 0.16 \text{ kWh/km} = 8 \text{ kWh} \end{aligned}$$

$$\frac{kWh}{km} = 8 \text{ kWh} \end{align*}$$

Learning Objectives

After this 90-minute block, you

- know the time constant τ and in particular calculate it.
- determine the time characteristic of the currents and voltages at the RC element for a given resistance and capacitance.
- know the continuity conditions of electrical quantities.
- know when (=according to which measure) the capacitor is considered to be fully charged/discharged, i.e. a steady state can be considered to have been reached.
- can calculate the energy content in a capacitor.
- can calculate the change in energy of a capacitor resulting from a change in voltage between the capacitor terminals.
- can calculate (initial) current, (final) voltage, and charge when balancing the charge of several capacitors (also via resistors).

Preparation at Home

Well, again

- read through the present chapter and write down anything you did not understand.
- Also here, there are some clips for more clarification under 'Embedded resources' (check the text above/below, sometimes only part of the clip is interesting).

For checking your understanding please do the following exercises:

- ...

90-minute plan

1. Warm-up (x min):
 1.
2. Core concepts & derivations (x min):
 1. ...
3. Practice (x min): ...
4. Wrap-up (x min): Summary box; common pitfalls checklist.

Conceptual overview

1. ...

Core content

Fig. 1: Capacitor in electrical circuit

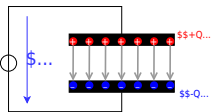

Here we will shortly introduce the basic idea behind a capacitor. A more detailed analysis will follow in electrical engineering II.

A capacitor consists of two insulated conductors (electrodes) separated by an insulator (cf. [figure 1](#)).

The electrodes serve as “charge carrier storage”. This is done in the following manner:

1. An external source draws charge carriers from one of the electrodes and carries them to the other electrode.
2. If the external source is a voltage source with the voltage U , a stationary state is reached after a certain time.
In this state there is a fixed number of $+Q$ on the positive electrode and $-Q$ on the negative electrode.
3. These charges form an electric field in the space between the electrodes. This field stores the supplied energy.

As larger the voltage U , more charges Q are stored on the electrode. This relationship is directly proportional to the proportionality constant C :

$$\begin{aligned} C &= \frac{Q}{U} \quad \text{with:} \quad [C] = 1 \frac{\text{As}}{\text{V}} = 1 \\ &= 1 \frac{\text{F}}{\text{F}} = 1 \text{ Farad} \end{aligned}$$

But it is not always directly recognizable that a structure contains a capacitor.

So the following examples are also capacitors:

- **open switch:** If there is a voltage between the two metal parts, charges can also accumulate there.
Since the distances are usually large and the air is used as the dielectric, the capacitance of the capacitor formed in this way is very small.
- **Overhead line:** An overhead line also represents a capacitor against the ground potential of the earth. The charging and discharging by the alternating current leads to the fact that polarizable molecules can align themselves. For example, the water drops near the line are rolled through the field and hum with $50\text{--}100\text{ Hz}$ and many times that (harmonics). Peak discharge results in a high-frequency crackle.
- **Conductor trace:** A trace on a PCB can also be a capacitor against a nearby ground plane. This can be a problem for digital signals (see the charge and discharge curves below).
- **Human body:** The human body can likewise pick up charge. The charge thus absorbed forms a capacitor with respect to other objects. This can be charged up to some kV . This is a particular problem in electrical laboratories, as the mere touching of components can destroy them.
- **Membrane of nerve cells:** Nerve cells also result in a capacitor due to the lipid bilayer (membrane of the nerve cell) and the two cellular fluids with different electrolytes (ions). The nerve cells are surrounded by a thick layer (myelin layer) for faster transmission. This lowers the capacitance and thus increases the successive charging of successive parts of the nerve cell. In diseases such as Creutzfeldt-Jakob or multiple sclerosis, this layer thins out. This leads to the delayed signal transmission which characterizes the disease patterns.

Fig. 2: Circuit for viewing charge and discharge curve

\$... \$...

In the following, the charging process of a capacitor is to be considered in more detail. For this purpose, one has to realize, that during the charging of the capacitor, besides the voltage source U_{s} and the capacitor C , there is always a resistance R in the circuit. This is composed of the internal resistance of the (non-ideal) voltage source, the internal resistance of the capacitor, and the parasitic (=interfering) resistance of the line. In practical applications, it is often desired that capacitors charge in a certain time range. For this purpose, another real resistor is inserted into the circuit. The resulting series of resistors and capacitors is called an **RC element**. It resembles a voltage divider in which a resistor has been replaced by a capacitor.

To start the charging, an (ideal) switch S is inserted. The circuit to be considered then looks like shown in [figure 2](#).

An ideal switch is characterized by:

- infinitely fast switching
- resistance of $0 \sim \Omega$ in the closed state ("short circuit")
- resistance $\rightarrow \infty$ in the open state ("open line")
- no capacitive effect

In this chapter also time-varying quantities are considered. These are generally marked with lowercase letters. Examples of time-varying quantities are:

- A **time-varying voltage $u_C(t)$ across a capacitor** or the **voltage U_{rms} of an ac voltage source** as opposed to a constant voltage U_{rms} across a constant voltage source.
- A **time-varying current $i_L(t)$ across a coil** or **time-varying current $i_C(t)$ across a capacitor**.

Since the time dependence is already clear from the lowercase letter, these quantities are occasionally not indicated by the trailing (t) . So it is $u = u(t)$.

Time Course of the Charging and Discharging Process

In the simulation below you can see the circuit mentioned above in a slightly modified form:

- The capacitance C can be charged via the resistor R if the toggle switch S connects the DC voltage source U_{rms} to the two.
- But it is also possible to short-circuit the series circuit of R and C via the switch S .
- Furthermore, the current i_C and the voltage u_C are displayed in the oscilloscope as data points over time and in the circuit as numerical values.
- Additionally it is possible to change the capacitance value C and resistance value R with the sliders Capacitance C and Resistance R .

Exercises:

1. Become familiar with how the capacitor current i_C and capacitor voltage u_C depend on the given capacitance C and resistance R .
To do this, use for $R = \{ 10 \sim \Omega, 100 \sim \Omega, 1 \sim k\Omega \}$ and $C = \{ 1 \sim \mu\text{F}, 10 \sim \mu\text{F} \}$. How fast does the capacitor voltage u_C increase in each case n ?
2. Which quantity (i_C or u_C) is continuous here? Why must this one be continuous? Why must the other quantity be discontinuous?

In the following, this circuit is divided into two separate circuits, which consider only charging and only discharging.

To understand the charging process of a capacitor, an initially uncharged capacitor with capacitance C is to be charged by a DC voltage source U_{rms} via a resistor R .

- In order that the voltage U_{rms} acts at a certain time $t_0 = 0 \sim s$ the switch S is closed at this time.
- Directly after the time t_0 the maximum current ("charging current") flows in the circuit. This is only limited by the resistor R . The uncharged capacitor has a voltage $u_C(t_0) = 0 \sim V$ at that time. The maximum voltage $u_R(t_0) = U_{\text{rms}}$ is applied to the resistor. The current is $i_C(t_0) = \frac{U_{\text{rms}}}{R}$.
- The current causes charge carriers to flow from one electrode to the other. Thus the capacitor is

- charged and its voltage increases u_C .
- Thus the voltage u_R across the resistor is reduced and so is the current i_R .
- With the current thus reduced, less charge flows on the capacitor.
- Ideally, the capacitor is not fully charged to the specified voltage U_{rms} until $t \rightarrow \infty$. It then carries the charge: $q(t \rightarrow \infty) = Q = C \cdot U_{\text{rms}}$

Fig. 2: circuit for viewing the charge curve

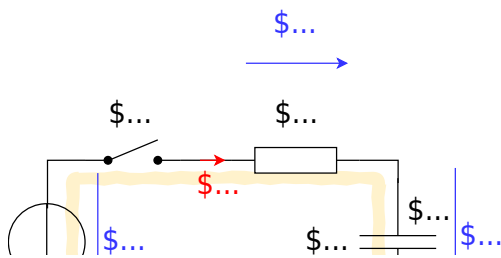

The process is now to be summarized in detail in formulas. Linear components are used in the circuit, i.e. the component values for the resistor R and the capacitance C are independent of the current or the voltage. Then definition equations for the resistor R and the capacitance C are also valid for time-varying or infinitesimal quantities:

$$\begin{aligned} R &= \frac{u_R(t)}{i_R(t)} = \frac{du_R}{di_R} = \text{const.} \quad \parallel C \\ &= \frac{q(t)}{u_C(t)} = \frac{dq}{du_C} = \text{const.} \quad \tag{5.1.1} \end{aligned}$$

Charging a capacitor at time $t=0$

By considering the loop, the general result is: the voltage of the source is equal to the sum of the two voltages across the resistor and capacitor.

$$U_{\text{rms}} = u_R + u_C = R \cdot i_C + u_C \tag{5.1.2}$$

At the first instant dt , an infinitesimally small charge “chunk” dq flows through the circuit driven by the current i_C from the voltage source. For this, (5.1.1) gives:

$$i_C = \frac{dq}{dt} \quad \text{and} \quad dq = C \cdot du_C$$

The charging current i_C can be determined from the two formulas:

$$i_C = C \frac{du_C}{dt} \tag{5.1.3}$$

Thus (5.1.2) becomes:

$$U_{\text{rs}} = u_R + u_C \quad \&= R \cdot C \frac{du_C}{dt} + u_C$$

here follows some mathematics:

This result represents a 1st order differential equation. This should generally be rewritten so that the part that depends (on the variable) is on one side and the rest is on the other. This is already present here. The appropriate approach to such a problem is:

$$u_C(t) = \mathcal{A} \cdot e^{\mathcal{B} \cdot t} + \mathcal{C}$$

$$\begin{aligned} U_{\text{rs}} &= R \cdot C \frac{d}{dt} (\mathcal{A} \cdot e^{\mathcal{B} \cdot t} + \mathcal{C}) + \mathcal{A} \cdot e^{\mathcal{B} \cdot t} + \mathcal{C} \\ &= R \cdot C \cdot \mathcal{A} \mathcal{B} \cdot e^{\mathcal{B} \cdot t} + \mathcal{A} \cdot e^{\mathcal{B} \cdot t} + \mathcal{C} \\ &= (R \cdot C \cdot \mathcal{A} \mathcal{B} + \mathcal{A}) \cdot e^{\mathcal{B} \cdot t} + \mathcal{C} \end{aligned}$$

This equation must hold for every t . This is only possible if the left, as well as the right term, become equal to 0.

Thus:

$$\begin{aligned} \mathcal{C} &= U_{\text{rs}} - (R \cdot C \cdot \mathcal{A} \mathcal{B} + \mathcal{A}) \cdot e^{\mathcal{B} \cdot t} \\ \quad | : \mathcal{A} \quad | -1 &= -1 \cdot (R \cdot C \cdot \mathcal{B} + 1) \cdot e^{\mathcal{B} \cdot t} \end{aligned}$$

So it follows:

$$u_C(t) = \mathcal{A} \cdot e^{\left\{-\frac{t}{RC}\right\}} + U_{\text{rs}}$$

For the solution it must still hold that at time $t_0=0$ $u_C(t_0) = 0$ just holds:

$$0 = \mathcal{A} \cdot e^{\{0\}} + U_{\text{rs}} \quad 0 = \mathcal{A} + U_{\text{rs}} \quad \mathcal{A} = -U_{\text{rs}}$$

So the solution is:

$$u_C(t) = -U_{\text{rs}} \cdot e^{\left\{-\frac{t}{RC}\right\}} + U_{\text{rs}}$$

And this results in:
$$u_C(t) = U_{\text{rs}} \cdot (1 - e^{\left\{-\frac{t}{RC}\right\}})$$

And with (5.1.3), i_C becomes:
$$i_C(t) = \frac{U_{\text{rs}}}{R} \cdot e^{\left\{-\frac{t}{RC}\right\}}$$

In [figure 4](#), the two time course diagrams for the charging voltage $u_C(t)$ and the charging current $i_C(t)$ of the capacitor are shown.

Fig. 4: charging curve

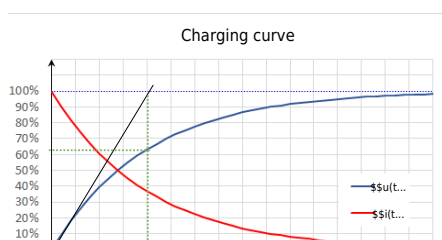

Notice:

- There must be a unitless term in the exponent. So RC must also represent a time. This time is called **time constant** $\tau = R \cdot C$.
- At time $t = \tau$, we get: $u_C(t) = U_{\text{rms}} \cdot (1 - \frac{1}{e}) = U_{\text{rms}} \cdot (1 - \frac{1}{2.718}) = U_{\text{rms}} \cdot \frac{1.718}{2.718} = 0.63 \cdot U_{\text{rms}} = 63\% \cdot U_{\text{rms}}$.
So, **the capacitor is charged to 63% after one τ .**
- At time $t = 2 \cdot \tau$ we get: $u_C(t) = U_{\text{rms}} \cdot (1 - \frac{1}{e^2}) = 86\% \cdot U_{\text{rms}} = (63\% + (100\% - 63\%) \cdot 63\%) \cdot U_{\text{rms}}$. So, **after each additional τ , the uncharged remainder (1-63%) is recharged to 63%.**
- After about $t = 5 \cdot \tau$, the result is a capacitor charged to over 99%. In real circuits, **a charged capacitor can be assumed after $5 \cdot \tau$.**
- The time constant τ can be determined graphically in several ways:
 - Plotting the voltage value corresponding to 63% on the y-axis. Finding the point of intersection with the graph. Reading the time (see green lines in [figure 4](#)).
 - Plotting the tangent to the (voltage) charge curve at the time of the discharged capacitor. This intersects a horizontal line at the level of the charging voltage at the point $t = \tau$ (see black and light blue lines in [figure 4](#)).

Discharging a capacitor at time $t=0$

Fig. 5: circuit for viewing discharge curve

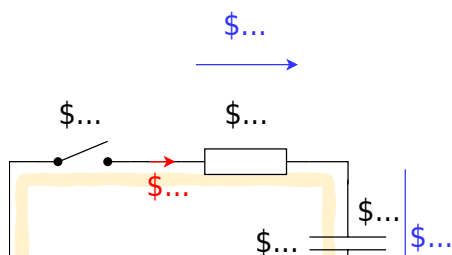

The following situation is considered for the discharge:

- A capacitor charged to voltage U_{rms} with capacitance C is short-circuited across a resistor R at time $t=t_0$.
- As a result, the full voltage U_{rms} is initially applied to the resistor: $u_R(t_0)=U_{\text{rms}}$
- The initial discharge current is thus defined by the resistance: $i_C = \frac{u_R}{R}$
- The discharging charges lower the voltage of the capacitor u_C , since: $u_C = \frac{q(t)}{C}$
- Ideally, the capacitor is not fully discharged before $t \rightarrow \infty$.

Also, this process now is to put into a formula in detail. By looking at the loop, the general result is: the sum of the two voltages across the resistor and capacitor adds up to zero.

$$\begin{aligned} 0 &= u_R + u_C = R \cdot i_C + u_C \end{aligned}$$

This gives (5.1.3):

$$\begin{aligned} 0 &= u_R + u_C = R \cdot C \cdot \frac{du_C}{dt} + u_C \end{aligned}$$

also here uses some mathematics:

This result again represents a 1st order differential equation. The appropriate approach to such a problem is:

$$\begin{aligned} u_C(t) &= \mathcal{A} \cdot e^{\mathcal{B}t} + \mathcal{C} \\ \end{aligned}$$

$$\begin{aligned} 0 &= R \cdot C \cdot \frac{d}{dt}(\mathcal{A} \cdot e^{\mathcal{B}t} + \mathcal{C}) + \mathcal{A} \cdot e^{\mathcal{B}t} + \mathcal{C} \\ &= R \cdot C \cdot \mathcal{A} \mathcal{B} \cdot e^{\mathcal{B}t} + \mathcal{A} \cdot e^{\mathcal{B}t} + \mathcal{C} \\ &= (R \cdot C \cdot \mathcal{A} \mathcal{B} + \mathcal{A}) \cdot e^{\mathcal{B}t} + \mathcal{C} \end{aligned}$$

This equation must hold for every t . This is only possible if the left, as well as the right term, become equal to 0. Thus:

$$\begin{aligned} \mathcal{C} &= 0 \\ R \cdot C \cdot \mathcal{A} \mathcal{B} + \mathcal{A} &= 0 \quad | : \mathcal{A} \\ -1 &= -1 \\ \frac{1}{RC} & \end{aligned}$$

So it follows:

$$\begin{aligned} u_C(t) &= \mathcal{A} \cdot e^{-\frac{t}{RC}} + 0 \\ \end{aligned}$$

For the solution it must still hold that at time $t_0=0$ $u_C(t_0) = U_s$ just holds:

$$\begin{aligned} U_s &= \mathcal{A} \cdot e^{\{0\}} \\ U_s & \end{aligned}$$

Therefore, the result is:

$$\begin{aligned} u_C(t) &= U_s \cdot e^{-\frac{t}{RC}} \end{aligned}$$

Fig. 6: discharge curve

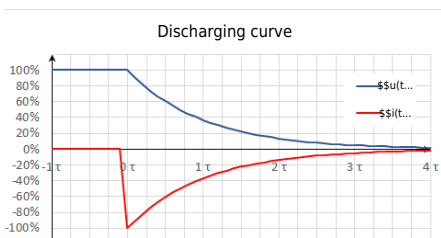

And this results in:
$$u_C(t) = U_s \cdot e^{-\frac{t}{\tau}}$$

$$\tau = R C$$

And with (5.1.3), i_C becomes:
$$i_C(t) = -\frac{U_s}{R} \cdot e^{-\frac{t}{R C}}$$

In figure 6 the two time course diagrams are again shown; now for the discharge voltage $u_C(t)$ and the discharge current $i_C(t)$ of the capacitor. Since the current now flows out of the capacitor, the sign of i_C is negative.

Periodic switching operations

In the simulation on the right, a periodic switching operation can be seen. The capacitor is periodically charged and discharged via the switch. Three sliders are given in the simulation to change the resistance R (Resistance R), the capacity C (Capacity C), and the frequency f (Frequency f). In the simulation below, the voltage u_C across the capacitor is shown in green and the current i_C is shown in yellow.

Exercises:

1. Increase the the frequency to $f=10 \sim \{\text{rm kHz}\}$ using the appropriate slider. What is the change for u_C and i_C ?
2. Now increase the capacitance to $C=10 \sim \{\text{rm }\mu\text{F}\}$ using the corresponding slider. What is the

change for u_C and i_C ?

- Now increase the resistance to $R = 1 \text{ k}\Omega$ using the corresponding slider. What is the change for u_C and i_C ?

Energy stored in a Capacitor

Fig. 2: circuit for viewing the charge curve

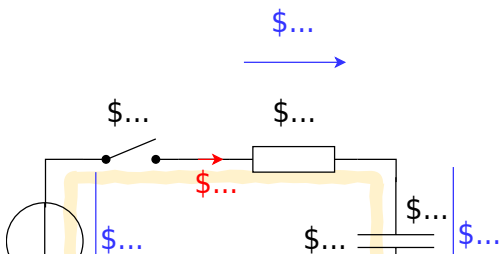

Now the capacitor as energy storage is to be looked at more closely. For this, we consider again the circuit in figure 2. According to the chapter [Preparation, Properties, and Proportions](#), the power for constant values (DC) is defined as:

$$P = \frac{\Delta W}{\Delta t} = U \cdot I$$

For variable signals, the instantaneous power is given as:

$$p = \frac{dw}{dt} = u \cdot i$$

Energy consideration of the capacitor

Charging the capacitor at time $t_0 = 0$ results in $\Delta W = \Delta W_C$ for the stored energy at a later time $t_1 = t$:

$$\Delta W_C = \int_{t_0}^{t_1} w = \int_0^t u \cdot i \cdot dt = \int_0^t u_C \cdot i_C \cdot dt \tag{5.2.1}$$

During the charging process $u_C(t) = U_s \cdot (1 - e^{-\frac{t}{\tau}})$ and $i_C(t) = \frac{U_s}{R} \cdot e^{-\frac{t}{\tau}}$

$\tag{5.2.2}$

In particular:

$$\begin{aligned} C = \frac{q(t)}{u_C(t)} \quad &\& \rightarrow \quad & q(t) = u_C(t) \cdot C \\ i_C(t) = \frac{dq(t)}{dt} \quad &\& \rightarrow \quad & C = \text{const.} \quad & i_C(t) = C \cdot \frac{du_C(t)}{dt} \end{aligned}$$

Thus, the stored energy from formula (5.2.1):

$$\begin{aligned} \Delta W_C &= \int_0^t u_C(t) \cdot C \cdot \frac{du_C(t)}{dt} dt \\ & \quad \& | \text{substitution of integration variable: } t \rightarrow u_C \quad & = \\ & \int_{U_0}^{U_1} u_C(t) \cdot C \cdot du_C \quad & \& | \text{Since the capacity is constant, it} \\ & \text{can be written ahead of the integral} \quad & = C \cdot \int_{U_0}^{U_1} u_C \cdot du_C \quad & = C \cdot \left[\frac{1}{2} u_C^2 \right]_{U_0}^{U_1} \end{aligned} \quad \boxed{\Delta W_C = \frac{1}{2} C (U_1^2 - U_0^2)} \tag{5.2.3}$$

Thus, for a fully discharged capacitor ($U_{\text{rms}}=0 \sim V$), the energy stored when charging to voltage U_{rms} is $\Delta W_C = \frac{1}{2} C \cdot U_{\text{rms}}^2$.

Energy Consideration on the Resistor

The converted energy can also be determined for the resistor:

$$\Delta W_R = \int_0^t u_R \cdot i_R dt = \int_0^t R \cdot i_R \cdot i_R dt = R \cdot \int_0^t i_R^2 dt$$

Since the current through the capacitor i_C is equal to that through the resistor i_R , it follows via (5.2.2):

$$\begin{aligned} \Delta W_R &= R \cdot \int_0^t \left(\frac{U_{\text{rms}}}{R} \cdot e^{-\frac{t}{\tau}} \right)^2 dt \\ &= \frac{U_{\text{rms}}^2}{R} \cdot \int_0^t e^{-\frac{2t}{\tau}} dt \\ &= \frac{U_{\text{rms}}^2}{R} \cdot \left[-\frac{\tau}{2} e^{-\frac{2t}{\tau}} \right]_0^t \\ &= -\frac{1}{2} \cdot \frac{U_{\text{rms}}^2}{R} \cdot \left(e^{-\frac{2t}{\tau}} - 1 \right) \cdot C \cdot \left(e^{-\frac{2t}{\tau}} \right) \end{aligned}$$

For $t \rightarrow \infty$ we get:

$$\begin{aligned} \Delta W_R &= -\frac{1}{2} \cdot \frac{U_{\text{rms}}^2}{R} \cdot C \cdot \left(e^{-\frac{2t}{\tau}} - 1 \right) \\ &= -\frac{1}{2} \cdot \frac{U_{\text{rms}}^2}{R} \cdot C \cdot \left(0 - 1 \right) \end{aligned} \quad \boxed{\Delta W_R = \frac{1}{2} C U_{\text{rms}}^2} \tag{5.2.4}$$

This means that the energy converted at the resistor is independent of the resistance value (for an ideal constant voltage source U_{rms} and given capacitor C)! At first, this doesn't really sound comprehensible. No matter if there is a very large resistor R_1 or a tiny small resistor R_2 : The same waste heat is always produced. Graphically, this apparent contradiction can be resolved like this: A higher resistor R_2 slows down the small charge packets Δq_1 , Δq_2 , ... Δq_n more strongly. But a considered single charge packet Δq_k will nevertheless pass the same voltage across the resistor R_1 or R_2 since this is given only by the accumulated packets in the capacitor: $u_r = U_{\text{rms}} - u_C = U_{\text{rms}} - \frac{q}{C}$.

In real applications, as mentioned in previous chapters, ideal voltage sources are not possible. Thus, without a real resistor, the waste heat is dissipated proportionally to the internal resistance of the source and the internal resistance of the capacitor. The internal resistance of the capacitor depends on the frequency but is usually smaller than the internal resistance of the source.

Consideration of total energy turnover

In the previous considerations, the energy conversion during the complete charging process was also considered. It was found that the capacitor stores the energy $W_C = \frac{1}{2} \cdot U_{\text{rms}}^2 \cdot C$ (see (5.2.3)) and at the resistor the energy $W_R = \frac{1}{2} \cdot U_{\text{rms}}^2 \cdot C$ (see (5.2.4)) into heat. So, in total, the voltage source injects the following energy:

$$\Delta W_0 = \Delta W_R + \Delta W_C = U_{\text{rms}}^2 \cdot C$$

This also follows via (5.2.1):

$$\begin{aligned} \Delta W_0 &= \int_0^{\infty} u_0 \cdot i_0 \cdot dt \quad | \quad u_0 = U_{\text{rms}} \text{ \textit{is constant because constant voltage source!}} \\ &= U_{\text{rms}} \cdot \int_0^{\infty} i_C \cdot dt \\ &= U_{\text{rms}} \cdot \int_0^{\infty} \frac{dq}{dt} \cdot dt \\ &= U_{\text{rms}} \cdot Q \\ &= U_{\text{rms}}^2 \cdot C \end{aligned}$$

This means that only half of the energy emitted by the source is stored in the capacitor! Again, This doesn't really sound comprehensible at first. And again, it helps to look at small packets of charge that have to be transferred from the ideal source to the capacitor. [figure 8](#) shows current and voltage waveforms across the capacitor and the stored energy for different resistance values. There, too, it can be seen that the maximum stored energy (dashed line in the figure at right) is given by $\Delta W = \frac{1}{2} \cdot U_{\text{rms}}^2 \cdot C$ alone. $U_{\text{rms}}^2 \cdot C = \frac{1}{2} \cdot (5\text{V})^2 \cdot 1\text{ }\mu\text{F} = 12.5\text{ }\mu\text{Ws}$ is given.

Fig. 8: Current, voltage, and energy during charging and discharging

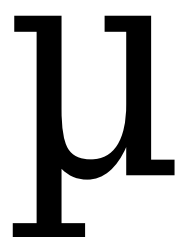
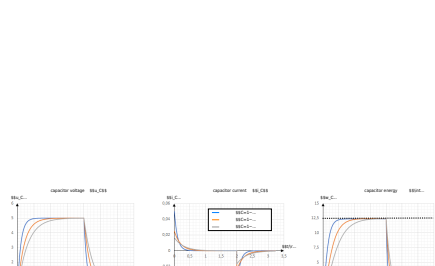

This can also be tested in the following simulation. In addition to the RC element shown so far, a power meter and an integrator are also drawn here. It is possible to display the instantaneous power and the stored energy. Via the slider Resistance R the resistance value can be varied. The following values are shown in the oscilloscopes:

- left: Current i_C and voltage u_C at the capacitor.
- middle: Instantaneous power $p_C = u_C \cdot i_C$ of the capacitor.

- right: stored energy $w_C = \int u_C \cdot i_C \, dt$ of the capacitor

Common pitfalls

- ...

Exercises

Worked examples

Exercise 1.1 Capacitor charging/discharging practice Exercise

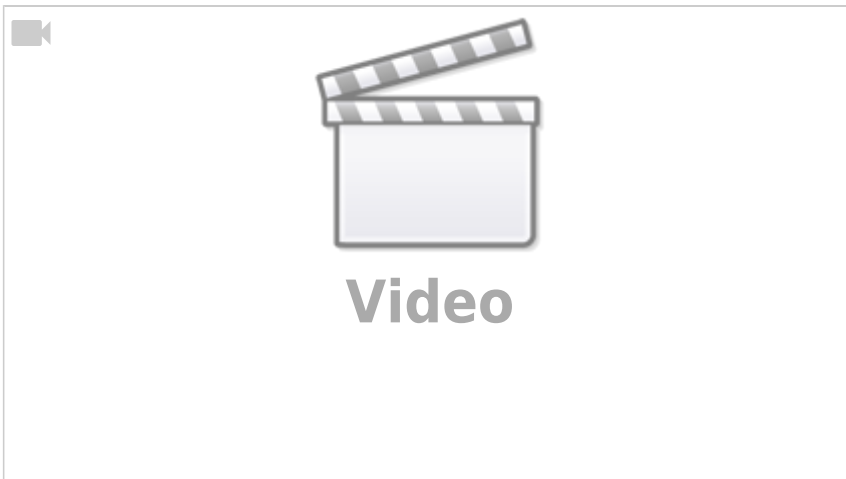

Exercise E 1.2 Capacitor charging/discharging

The circuit in the image consists of a battery with $\mathcal{E} = 10 \text{ V}$, a resistor with $R = 10 \text{ k}\Omega$, and a capacitor with $C = 1 \text{ }\mu\text{F}$. The switch is initially open. At $t = 0$, the switch is closed. The voltage across the capacitor is $U_C(t)$ and the current through the resistor is $i_R(t)$. The values of the components shall be the following:

The values of the components shall be the following:

Solution: What is the new time constant τ_2 ?

Solution: $R_1 = 1.0 \text{ k}\Omega$
Solution: $\tau_1 = R_1 C = 1.0 \text{ ms}$
Solution: $R_2 = 1.0 \text{ k}\Omega$
<ul style="list-style-type: none"> • $C = 1 \text{ }\mu\text{F}$
To calculate the moment $t_{0.25}$ when $U_C(t_{0.25})$ is smaller than $1/10 \cdot U_2$, we first have to find out the value of U_2 at the circuit, but this time when S_2 is closed. We can derive $U_C(t)$ based on the exponential function: $U_C(t) = U_1 \cdot (1 - e^{-t/\tau})$. Again, the time constant τ is given as: $\tau = R \cdot C$.
Therefore, we get $t_{0.25} = 10 \text{ ms} \cdot \ln(10)$. Which is $t_{0.25} = 23 \text{ ms}$. The charge on the capacitor is $Q = C \cdot U_C(t_{0.25}) = 1 \text{ }\mu\text{F} \cdot 10 \text{ V} \cdot (1 - e^{-10/23}) = 1 \text{ }\mu\text{F} \cdot 10 \text{ V} \cdot (1 - e^{-0.435}) = 1 \text{ }\mu\text{F} \cdot 10 \text{ V} \cdot 0.35 = 3.5 \text{ }\mu\text{C}$.
To find the capacitor, we have to look at the circuit when S_1 is open and S_2 is closed. Before $t = 0$, $U_C = 0$ and $i_R = 0$. At $t = 0$, the switch S_1 is opened and $U_C(t) = U_1 \cdot (1 - e^{-t/\tau_1})$ and $i_R(t) = \frac{U_1}{R_1} \cdot (1 - e^{-t/\tau_1})$.

(1/5) This is also true for t_2 , since between t_1 and t_2 the charge on C does not change: $u_c(t_2) = 4 \text{ V}$.

- In the first moment after closing S_2 at t_2 , the voltage drop on $R_3 + R_2$ is: $U_{R3+R2} = U_2 - u_c(t_2) = 6 \text{ V}$.
- So the voltage divider of $R_3 + R_2$ lead to $u_{R2}(t_2 = 10 \text{ ms}) = \frac{R_2}{R_3 + R_2} \cdot U_{R3+R2} = \frac{2 \text{ k}\Omega}{3 \text{ k}\Omega + 2 \text{ k}\Omega} \cdot 6 \text{ V} = 2.4 \text{ V}$

We see that the voltage on R_2 has to decrease from 2.4 V to $1/10 \cdot U_2 = 1 \text{ V}$.

To calculate this, there are multiple ways. In the following, one shall be retraced:

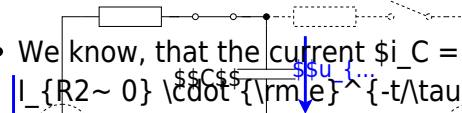

- We know, that the current $i_C = i_{R2}$ subsides exponentially: $i_{R2}(t) = I_{R2 \sim 0} \cdot e^{-t/\tau}$

So we can rearrange the task to focus on the change in current instead of the voltage.

We see that $U_1 = u_C + u_{R2}$ and there is only one current in the loop: $i = i_C = i_{R2}$. The exponential decay is true regardless of where it starts.

The current is generally given with the exponential function: $i_C = \frac{U_1}{R_1 + R_2} \cdot e^{-t/\tau}$, with R given here as $R = R_1 + R_2$. Therefore u_{R2} can be written as: $u_{R2}(t) = \frac{R_2}{R_1 + R_2} \cdot U_1 \cdot e^{-t/\tau}$

$$u_{R2}(t_3) = \frac{R_2}{R_1 + R_2} \cdot U_1 \cdot e^{-t_3/\tau} = 10 \text{ V} \cdot \frac{2 \text{ k}\Omega}{3 \text{ k}\Omega + 2 \text{ k}\Omega} \cdot e^{-10 \text{ ms}/\tau} = 2.4 \text{ V}$$

We see that for the time constant, we now need to use $R = R_3 + R_2$.

For the first task, the switch S_1 gets closed at $t_1 = 0 \text{ s}$.

1.1 What is the value of the time constant τ_1 ?

Solution

The time constant τ is generally given as: $\tau = R \cdot C$.

Now, we try to determine which R and C must be used here.

To find this out, we have to look at the circuit when S_1 gets closed.

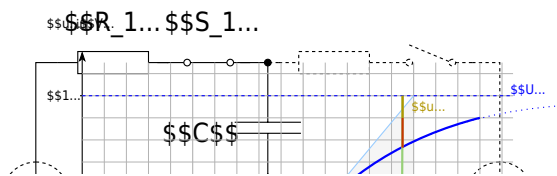

We see that for the time constant, we need to use $R=R_1 + R_2$.

Exercise E1.3 Charge balance of two capacitors (educational exercise, not part of an exam)

In the simulation, you see the two capacitors C_1 and C_2 (The two small resistors with $1 \sim \mu\Omega$ have to be there for the simulation to run). At the beginning, C_1 is charged to $10 \sim \text{V}$ and C_2 to $0 \sim \text{V}$. With the switches S_1 and S_2 you can choose whether

1. the capacitances C_1 and C_2 are shorted, or
2. the capacitors C_1 and C_2 are connected via resistor R .

On the right side of the simulation, there are some additional “measuring devices” to calculate the stored potential energy from the voltages across the capacitors.

In the following, the charging and discharging of a capacitor are to be explained with this construction.

Under the electrical structure, the following quantities are shown over time:

Voltage $u_1(C_1)$ of the first capacitor	Voltage $u_2(C_2)$ of the second capacitor	Stored energy $w_1(C_1)$	Stored energy $w_2(C_2)$	Total energy $\sum w$
Initially charged to $10\text{~}\{\text{rm V}\}$	Initially neutrally charged ($0\text{~}\{\text{rm V}\}$)	Initially holds: $w_1(C_1) = \frac{1}{2} \cdot C \cdot U^2 = \frac{1}{2} \cdot 10\text{~}\{\text{rm }\mu\text{F}\} \cdot (10\text{~}\{\text{rm V}\})^2 = 500\text{~}\{\text{rm }\mu\text{W}\}$ In the oscilloscope, equals $1\text{~}\{\text{rm V}\} \sim 1\text{~}\{\text{rm W}\}$	Initially, $w_2(C_2) = 0$, since the capacitor is not charged.	The total energy is $w_1 + w_2 = w_1$

The capacitor C_1 has thus initially stored the full energy and via closing of the switch, S_2 one would expect a balancing of the voltages and an equal distribution of the energy $w_1 + w_2 = 500\text{~}\{\text{rm }\mu\text{W}\}$.

1. Close the switch S_2 (the toggle switch S_1 should point to the switch S_2).
 What do you find?
 1. What do the voltages u_1 and u_2 do?
 2. What are the energies and the total energy?
 How is this understandable with the previous total energy?
2. Open S_2 - the changeover switch S_1 should not be changed. What do you find?
 1. What do the voltages u_1 and u_2 do?
 2. What are the energies and the total energy?
 How is this understandable with the previous total energy?
3. Repeat 1. and 2. several times. Can anything be deduced regarding the distribution of energy?
4. Change the switch S_2 to the resistor. What do you observe?
 1. What do the voltages u_1 and u_2 do?
 2. What are the energies and the total energy?
 How is this understandable with the previous total energy?

Exercise E1.4 Machine-Vision Strobe Unit: Charging and Safe Discharge of a Flash Capacitor

A machine-vision inspection system on a production line uses a short high-voltage flash pulse. For this purpose, an energy-storage capacitor is charged from a DC source and must be safely discharged before maintenance.

Data: $C = 1\text{~}\{\text{rm }\mu\text{F}\}$ $W_e = 0.1\text{~}\{\text{rm J}\}$ $I_{\text{max}} = 100\text{~}\{\text{rm mA}\}$ $R_i = 10\text{~}\{\text{rm M}\Omega\}$

1. What voltage must the capacitor have so that it stores the required energy?

SolutionResult

```
\begin{align*} W_e &= \frac{1}{2} C \\ U^2 \\ U &= \sqrt{\frac{2W_e}{C}} \\ &= \sqrt{\frac{2 \cdot 0.1 \text{ J}}{1 \\ \cdot 10^{-6} \text{ F}}} \\ &= \sqrt{200000} \text{ V} \approx \\ 447.2 \text{ V} \end{align*}
```

```
\begin{align*} U &= 447.2 \text{ V} \\ \end{align*}
```

2. The charging current must not exceed 100 mA at the start of charging. What charging resistor is required?

SolutionResult

At the beginning of charging, the capacitor behaves like a short circuit, so $i_{C \text{ max}} = i_C(t=0) = \frac{U}{R}$. Thus, $R \geq \frac{U}{i_{\text{max}}} = \frac{447.2 \text{ V}}{0.1 \text{ A}} \approx 4472 \text{ } \Omega = 4.47 \text{ k}\Omega$.

```
\begin{align*} R &\geq 4.47 \text{ k}\Omega \\ \end{align*}
```

3. How long does the charging process take until the capacitor is practically fully charged?

SolutionResult

The time constant is $T = RC = 4.47 \text{ k}\Omega \cdot 1 \text{ } \mu\text{F} = 4.47 \text{ ms}$

```
\begin{align*} t &\approx 22.35 \text{ ms} \\ \end{align*}
```

\end{align*} In engineering practice, a capacitor is considered practically fully charged after about $5T$:

$$\begin{align*} t \approx 5T = 5 \cdot 4.47 \text{ ms} = 22.35 \text{ ms} \end{align*}$$

\end{align*}

4. Give the time-dependent capacitor voltage and the voltage across the charging resistor.

SolutionResult

For the charging process:

$$\begin{align*} u_C(t) &= U \left(1 - e^{-t/T}\right) \\ u_R(t) &= U e^{-t/T} \end{align*}$$

with $\begin{align*} U &= 447.2 \text{ V} \\ T &= 4.47 \text{ ms} \end{align*}$ So the capacitor voltage rises exponentially from 0 to 447.2 V , while the resistor voltage falls exponentially from 447.2 V to 0 .

$$\begin{align*} u_C(t) &= 447.2 \left(1 - e^{-t/4.47 \text{ ms}}\right) \text{ V} \\ u_R(t) &= 447.2 e^{-t/4.47 \text{ ms}} \text{ V} \end{align*}$$

5. After charging, the capacitor is disconnected from the source. Its leakage can be modeled by an internal resistance of $10 \text{ M}\Omega$. After what time has the stored energy dropped to one half, and what is the capacitor voltage then?

SolutionResult

Half the energy means $\begin{align*} W_{e'} = 0.5 W_e \end{align*}$ Since $\begin{align*} W_e = \frac{1}{2} C U^2 \end{align*}$ the voltage at half energy is

$$\begin{align*} U' &= 316.2 \text{ V} \\ t &= 3.47 \text{ s} \end{align*}$$

```

\begin{align*} U' = \\
\frac{U}{\sqrt{2}} = \\
\frac{447.2 \sim \{\rm V\}}{\sqrt{2}} = \\
316.2 \sim \{\rm V\} \end{align*} For the
discharge through the internal
resistance: \begin{align*} u_C(t) = \\
Ue^{-t/T_2} \end{align*} with
\begin{align*} T_2 = R_i C = 10 \sim \{\rm \\
M\Omega\} \cdot 1 \sim \{\rm \mu F\} = \\
10 \sim \{\rm s\} \end{align*} Set
u_C(t)=U': \begin{align*} Ue^{- \\
t/T_2} \&= U' \ \&t \&= T_2 \\
\ln\left(\frac{U}{U'}\right) \ \&= \\
10 \sim \{\rm \\
s\} \cdot \ln\left(\frac{447.2}{316.2}\right) \\
\end{align*} \ \&\approx 3.47 \sim \{\rm s\} \\
\end{align*}

```

6. The fully charged capacitor is discharged through the charging resistor before maintenance. How long does the discharge take, and how much energy is converted into heat in the resistor?

SolutionResult

The discharge time constant through the same resistor is again

```

\begin{align*} T = RC = 4.47 \sim \{\rm \\
ms\} \end{align*} Thus the practical
discharge time is \begin{align*} t \\
\approx 5T = 22.35 \sim \{\rm ms\} \\
\end{align*} The complete stored
capacitor energy is converted into
heat in the resistor: \begin{align*} \\
W_R = W_e = 0.1 \sim \{\rm Js\} \\
\end{align*}

```

```

\begin{align*} t \approx 22.35 \sim \{\rm \\
ms\} \ \&W_R = 0.1 \sim \{\rm Js\} \\
\end{align*}

```

Exercise E1.5 Sensor Input Buffer: Source, T-Network and Capacitor

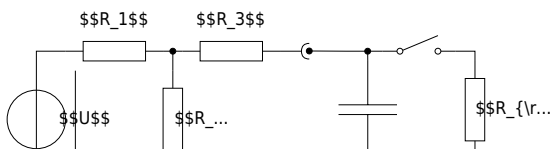

A 12 V industrial sensor electronics unit feeds a buffered measurement node through a resistor T-network. A capacitor smooths the node voltage. At first, the load is disconnected. After the capacitor is fully charged, a measurement load is connected by a switch.

Data:
$$\begin{aligned} U &= 12 \text{ V} \\ R_1 &= 2 \text{ k}\Omega \\ R_2 &= 10 \text{ k}\Omega \\ R_3 &= 3.33 \text{ k}\Omega \\ C &= 2 \text{ }\mu\text{F} \\ R_L &= 5 \text{ k}\Omega \end{aligned}$$

Initially, the capacitor is uncharged and the switch is open.

1. What is the capacitor voltage after it is fully charged?

SolutionResult

Using the equivalent voltage source of the network on the left-hand side, the open-circuit voltage is

$$\begin{aligned} U_{0e} &= \frac{R_2}{R_1 + R_2} U \\ &= \frac{10 \text{ k}\Omega}{2 \text{ k}\Omega + 10 \text{ k}\Omega} \cdot 12 \text{ V} \\ &= 10 \text{ V} \end{aligned}$$

After full charging, the capacitor voltage equals this voltage.

$$\begin{aligned} U_C = U_{0e} &= 10 \text{ V} \end{aligned}$$

2. How long does the charging process take?

SolutionResult

The internal resistance seen by the capacitor is $R_{ie} = R_3 + (R_1 \parallel R_2) = 3.33 \text{ k}\Omega + \frac{2 \text{ k}\Omega}{2} = 3.33 \text{ k}\Omega + 1 \text{ k}\Omega = 4.33 \text{ k}\Omega$. So the time constant is $T = R_{ie}C = 4.33 \text{ k}\Omega \cdot 2 \text{ }\mu\text{F} = 8.66 \text{ ms}$. Practical charging time: $t \approx 5T = 43.3 \text{ ms}$.

$$R_{ie} = 5.00 \text{ k}\Omega \quad t \approx 50 \text{ ms}$$

3. Give the time-dependent capacitor voltage.

SolutionResult

The charging law is $u_C(t) = U_{0e} \left(1 - e^{-t/T}\right) = 10 \left(1 - e^{-t/10 \text{ ms}}\right) \text{ V}$. So the capacitor voltage rises exponentially from 0 V to 10 V .

$$u_C(t) = 10 \left(1 - e^{-t/10 \text{ ms}}\right) \text{ V}$$

4. After the capacitor is fully charged, the switch is closed and the load resistor is connected. What is the stationary load voltage?

SolutionResult

Now use a second equivalent voltage-source step. The Thevenin source seen by the load has
$$U_{0e} = 10 \text{ V} \quad R_{ie} = 5.00 \text{ k}\Omega$$
 Thus, the stationary load voltage is
$$U_{C'} = U_{0e}' = \frac{R_L}{R_{ie} + R_L} U_{0e} = \frac{5 \text{ k}\Omega}{5 \text{ k}\Omega + 5 \text{ k}\Omega} \cdot 10 \text{ V} = 5 \text{ V}$$

$$\begin{aligned} U_L &= 5 \text{ V} \\ \end{aligned}$$

5. How long does it take until this new stationary state is practically reached?

SolutionResult

The new internal resistance is
$$R_{ie}' = R_{ie} \parallel R_L = 5.00 \text{ k}\Omega \parallel 5.00 \text{ k}\Omega = 2.50 \text{ k}\Omega$$
 Hence the new time constant is
$$T' = R_{ie}' C = 2.50 \text{ k}\Omega \cdot 2 \text{ }\mu\text{F} = 5 \text{ ms}$$
 Practical settling time:
$$t \approx 5T' = 25 \text{ ms}$$

$$\begin{aligned} R_{ie}' &= 2.50 \text{ k}\Omega \\ t &\approx 25 \text{ ms} \\ \end{aligned}$$

6. Give the time-dependent load voltage after the switch is closed.

SolutionResult

At the switching instant, the capacitor voltage cannot jump. Therefore:

$$\begin{aligned} u_L(0^+) &= 10 \text{ V} \\ u_L(\infty) &= 5 \text{ V} \end{aligned}$$

The voltage therefore decays exponentially toward the new final value:

$$\begin{aligned} u_L(t) &= u_L(\infty) + \left(u_L(0^+) - u_L(\infty) \right) e^{-t/T'} \\ &= 5 + 5e^{-t/5 \text{ ms}} \text{ V} \end{aligned}$$

$$\begin{aligned} u_L(t) &= 5 + 5e^{-t/5 \text{ ms}} \text{ V} \end{aligned}$$

Exercise E1.6 Hall-Sensor Calibration Coil: Short Air-Core Coil

A Hall-sensor calibration bench uses a short air-core coil to create a defined magnetic field. An air-core coil is chosen because it avoids hysteresis and remanence effects. The coil is wound as a short cylindrical coil.

Data:
$$\begin{aligned} l &= 22 \text{ mm} \\ d &= 20 \text{ mm} \\ d_{\text{Cu}} &= 0.8 \text{ mm} \\ N &= 25 \\ \rho_{\text{Cu}, 20^\circ \text{C}} &= 0.0178 \text{ } \Omega \cdot \text{mm}^2/\text{m} \end{aligned}$$

A DC current of 1 A shall flow through the coil.

1. Calculate the coil resistance R at room temperature.

SolutionResult

The wire cross section is

$$A_{\text{Cu}} = \pi \left(\frac{d_{\text{Cu}}}{2} \right)^2 = \pi (0.4 \text{ mm})^2 \approx 0.503 \text{ mm}^2$$

The total wire length is approximated by the number of turns times the circumference:

$$l_{\text{Cu}} = N \pi d \approx 25 \pi \cdot 20 \text{ mm} = 1570.8 \text{ mm} = 1.571 \text{ m}$$

Thus,

$$R = \frac{\rho_{\text{Cu}} l_{\text{Cu}}}{A_{\text{Cu}}} \approx 0.0178 \text{ m}\Omega \cdot \frac{1.571 \text{ m}}{0.503 \text{ mm}^2} \approx 0.0556 \text{ m}\Omega$$

$$R = 55.6 \text{ m}\Omega$$

2. Calculate the coil inductance \$L\$.

SolutionResult

For this short air-core coil, use

$$L = N^2 \cdot \frac{\mu_0}{4\pi} \cdot \frac{1}{1 + \frac{d}{2l}}$$

with

$$A = \pi \left(\frac{d}{2} \right)^2 = \pi (10 \text{ mm})^2 = 314.16 \text{ mm}^2 = 3.1416 \cdot 10^{-4} \text{ m}^2$$

$$\mu_0 = 4\pi \cdot 10^{-7} \text{ Vs/(Am)}$$

Therefore,

$$L = 25^2 \cdot \frac{4\pi \cdot 10^{-7}}{4\pi} \cdot \frac{1}{1 + \frac{0.01}{0.22}} \cdot 3.1416 \cdot 10^{-4} \cdot 10^{-3}$$

$$L = 7.71 \text{ }\mu\text{H}$$

```
\frac{1}{1+\frac{20}{2\cdot 22}} \\\
&\approx 7.71\cdot 10^{-6}\sim{\rm H} \\
\end{align*}
```

3. Which DC voltage must be applied so that the stationary current becomes $I=1\sim{\rm A}$? How large is the current density j in the copper wire?

SolutionResult

In the stationary DC state, the coil behaves like its ohmic resistance:

```
\begin{align*} U &= RI \\\ &= 55.6\sim{\rm m\Omega}\cdot 1\sim{\rm A} \\\ &= 55.6\sim{\rm mV} \\
\end{align*}
```

The current density is

```
\begin{align*} j &= \frac{I}{A_{\rm Cu}} \\\ &= \frac{1\sim{\rm A}}{0.503\sim{\rm mm}^2} \\\ &\approx 1.99\sim{\rm A/mm}^2 \\
\end{align*}
```

```
\begin{align*} U &= 55.6\sim{\rm mV} \\\
j &= 1.99\sim{\rm A/mm}^2 \\
\end{align*}
```

4. How much magnetic energy is stored in the coil in the stationary state?

SolutionResult

```
\begin{align*} W_m &= \\
\frac{1}{2}LI^2 &= \\
\frac{1}{2}\cdot 7.71\cdot \\
10^{-6}\sim{\rm H}\cdot (1\sim{\rm A})^2 &= 3.86\cdot 10^{-6}\sim{\rm Ws} \\
\end{align*}
```

```
\begin{align*} W_m &= 3.86\cdot \\
10^{-6}\sim{\rm Ws} & \\
\end{align*}
```

5. Give the time-dependent coil current $i(t)$ when the coil is switched on.

SolutionResult

A coil current cannot jump instantly. It starts at 0 and approaches the final value $I=1\text{~}\text{A}$ exponentially:

$$i(t) = \left(1 - e^{-t/T}\right)$$
 So the sketch starts at $0\text{~}\text{A}$, rises quickly, and then slowly approaches $1\text{~}\text{A}$.

$$i(t) = 1 \left(1 - e^{-t/T}\right) \text{~}\text{A}$$

6. How long does it take until the current has practically reached its stationary value?

SolutionResult

The time constant is $T = \frac{L}{R} = \frac{7.71\text{~}\text{mH}}{55.6\text{~}\text{m}\Omega} \approx 138.9\text{~}\mu\text{s}$
 A practical final value is reached after about $5T$:

$$t \approx 5T = 5 \cdot 138.9\text{~}\mu\text{s} \approx 695\text{~}\mu\text{s}$$

$$t \approx 695\text{~}\mu\text{s}$$

7. How much energy is dissipated as heat in the coil resistance during the current build-up?

SolutionResult

Using the current from task 5,

$$i(t) = I \left(1 - e^{-t/T}\right)$$
the heat dissipated in the winding resistance up to the practical final time $5T$ is

$$W_R = \int_0^{5T} R i^2(t) dt = R I^2 \int_0^{5T} \left(1 - e^{-t/T}\right)^2 dt$$
For this interval, the integral is approximately

$$\int_0^{5T} \left(1 - e^{-t/T}\right)^2 dt \approx \frac{7}{2} T$$
Thus,

$$W_R \approx R I^2 \cdot \frac{7}{2} T = 0.0556 \Omega \cdot (1 \text{ A})^2 \cdot \frac{7}{2} \cdot 138.9 \mu\text{s} \approx 27.05 \cdot 10^{-6} \text{ Ws}$$

$$W_R \approx 27.05 \cdot 10^{-6} \text{ Ws}$$

Embedded resources

Here is a short introduction about the transient behavior of an RC element (starting at 15:07 until 24:55)

Mathematical explanation of charging a capacitor

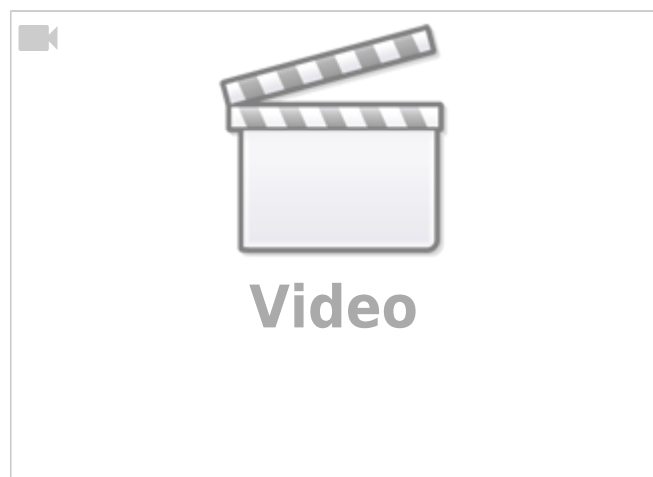

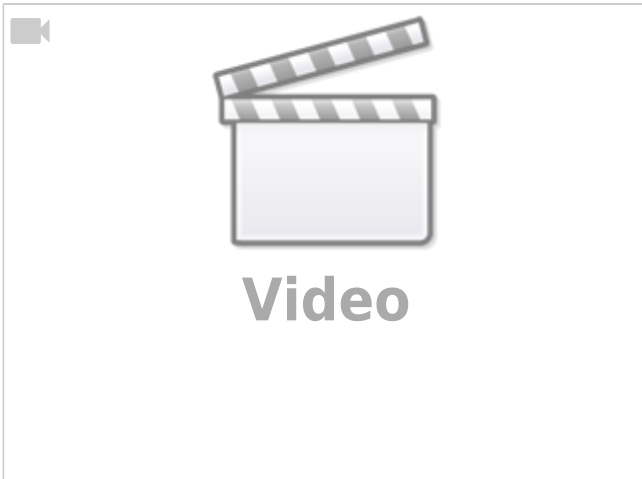

Mathematical explanation of discharging a capacitor

Mathematical explanation of the energy stored in the capacitor

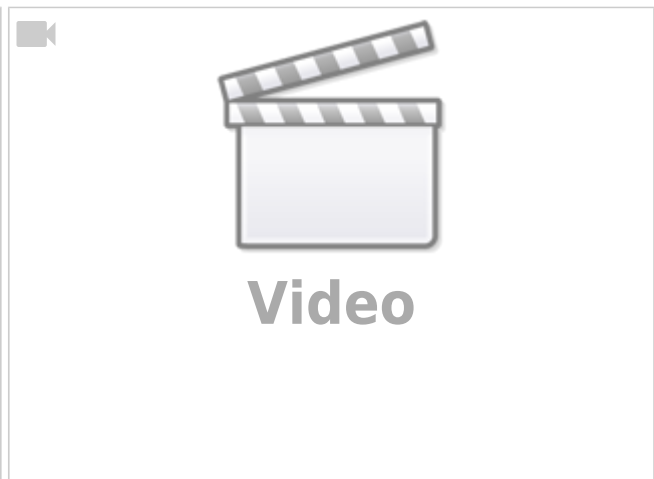
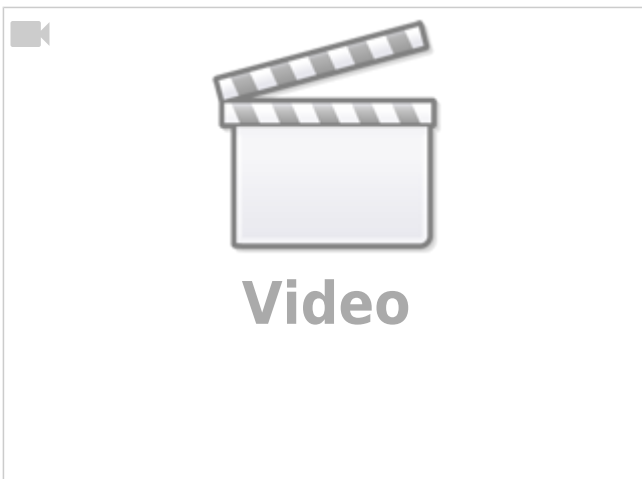

1.2 Introduction to the Structure of Matter

Learning Objectives

By the end of this section, you will be able to:

1. know the size of the elementary charge

Elementary Charge

Charge in Matter

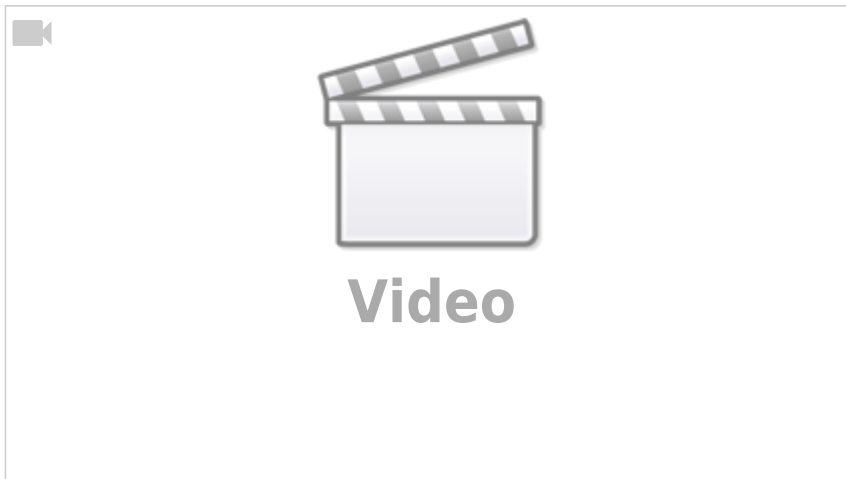

- Explanation of the charge based on the atomic models according to Bohr and Sommerfeld (see [figure 9](#))
- Atoms consist of
 - Atomic nucleus (with protons and neutrons)
 - Electron shell
- Electrons are carriers of the elementary charge $|e|$
- elementary charge $|e| = 1.6022 \cdot 10^{-19} \sim \text{C}$
- Proton is the antagonist, i.e. has the opposite charge
- Sign is arbitrarily chosen:
 - Electron charge: $-e$
 - proton charge: $+e$
- All charges on/in bodies can only occur as integer multiples of the elementary charge.
- Due to the small numerical value of e , the charge is considered as a continuum when viewed macroscopically.

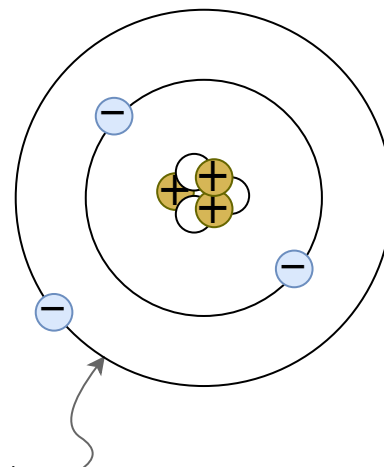

Fig. 9: Atomic model according to Bohr / Sommerfeld

quantu
Text is not SVG - cannot display

Conductivity of Matter

Conductor	Semiconductor	Isolator	Exercis
-----------	---------------	----------	----------------

Charge carriers are freely movable in the conductor.

Examples:

- Metals
- Plasma

In semiconductors, charge carriers can be generated by heat and light irradiation. Often a small movement of electrons is already possible at room temperature.

Examples:

- Silicon
- Diamond

In the insulator, charge carriers are firmly bound to the atomic shells.

Examples:

- many plastics and salts

es

Exercise E13 Charges on a Balloon

A balloon has a charge of $Q = 7 \times 10^{-9} \text{ C}$ on its surface. How many additional electrons are on the balloon?

Solution

$$Q = 7 \times 10^{-9} \text{ C} = 7 \cdot 10^{-9} \text{ C} \\ n_e = \frac{7 \cdot 10^{-9} \text{ C}}{1.6022 \cdot 10^{-19} \text{ C/electro}}$$

```
n}} =
43.7*10
^{9}~{\rm
electron
s}
\end{ali
gn*}
```

Exercise E14 Charges on a Ballon

A balloon has a charge of $Q=7\text{~}\{\rm nC\}$ on its surface.

Result How many additional electrons are on the balloon?

Solution

```
\begin{align*} 43.7*10^{9}~{\rm electrons} \end{align*}
```

```
\begin{align*} Q &= 7\text{~}\{\rm nC\} = 7\cdot 10^{-9}\text{~}\{\rm C\} \\ n_{\rm e} &= \frac{7*10^{-9}\text{~}\{\rm C\}}{1.6022*10^{-19}\text{~}\{\rm C/electron\}} = \\ 43.7*10^{9}\text{~}\{\rm electrons} \end{align*}
```

Exercise E15 Charges in Electroplating

To get a different metal coating onto a surface, often [Electroplating](#) is used. In this process, the surface is located in a liquid, which contains metal ions of the coating.

In the following, a copper coating (e.g. for corrosion resistance) shall be looked on. The charge of one copper ion is around $1.6022\cdot 10^{-19}\text{~}\{\rm C\}$, what is the charge on the surface if there are $8\cdot 10^{22}\text{~}\{\rm ions\}$ added?

```
\begin{align*} 12'818\text{~}\{\rm C\} \end{align*}
```

Solution

```
\begin{align*} 8 * 10^{22} \cdot 1.6022 * 10^{-19}\text{~}\{\rm C\} = 12'817.6\text{~}\{\rm C\} \\ \end{align*}
```

Exercise E16 Charges in Electroplating

To get a different metal coating onto a surface, often **Electroplating** is used. In this process, the surface is located in a liquid, which contains metal ions of the coating.

In the following, a copper coating (e.g. for corrosion resistance) shall be looked on. The charge of one copper ion is around $1.6022 \cdot 10^{-19} \text{ C}$, what is the charge on the surface if there are $8 \cdot 10^{22}$ ions added?

$$\begin{aligned} & 12'818 \text{ C} \end{aligned}$$

Solution

$$\begin{aligned} & 8 \cdot 10^{22} \cdot 1.6022 \cdot 10^{-19} \text{ C} = 12'817.6 \text{ C} \end{aligned}$$

1.3 Effects of Electric Charges and Current

Learning Objectives

By the end of this section, you will be able to:

1. Know that forces act between charges.
2. Know and be able to apply Coulomb's law.

- What effects of electric charges and current do you know?

First Approximation to the el. Charge

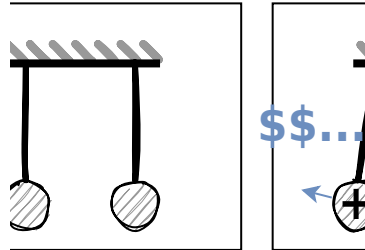

Fig. 10: Experiment 1 with two suspended charges

- first attempt (see [figure 10](#)):
 - Two charges (Q_1 and Q_2) are suspended at a distance of r .
 - Charges are generated by the high-voltage source and transferred to the two test specimens
- Result

- samples with same charges \rightarrow repulsion
- samples with charges of different sign \rightarrow attraction
- Findings
 - Forces cannot be explained mechanically
 - There seem to be two different types of charges. \rightarrow positive (+) and negative (-) charge

Coulomb-Force

Setup for own experiments

Take a charge ($+1 \sim \text{nC}$) and position it. Measure the field across a sample charge (a sensor).

Experiment with Coulomb's law and some calculated exercises

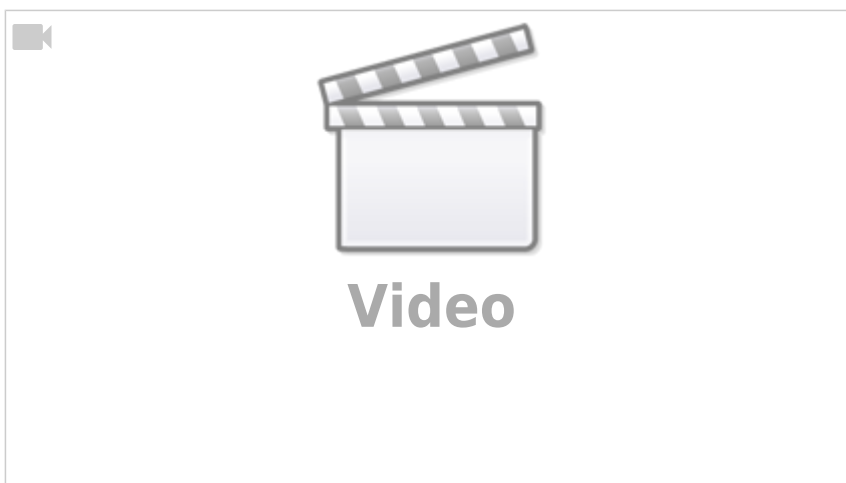

- Qualitative investigation using a second experiment
 - two charges (Q_1 and Q_2) at distance r
 - additional measurement of the force F_{C} (e.g. via spring balance)
- Experiment results:
 - Force increases linearly with larger charge Q_1 or Q_2 .
 $F_{\text{C}} \sim Q_1$ and $F_{\text{C}} \sim Q_2$
 - Force falls quadratic with greater distance r
 $F_{\text{C}} \sim \frac{1}{r^2}$
 - with a proportionality factor a :
 $F_{\text{C}} = a \cdot \frac{Q_1 \cdot Q_2}{r^2}$
- Proportionality factor a
- The proportionality factor a is defined to create simpler relations in electrodynamics.
 - a thus becomes:
 - $a = \frac{1}{4\pi \cdot \epsilon_0}$
 - ϵ_0 is the **Coulomb constant** (also called electric field constant). In a vacuum,
 $\epsilon_0 = \epsilon_0$.
- The formula is similar to that of the gravitational force: $F_G = \gamma \cdot \frac{m_1 \cdot m_2}{r^2}$

Note!

The Coulomb force (in a vacuum) can be calculated via.

$$\boxed{F_{\text{C}} = \frac{1}{4\pi\epsilon_0} \cdot \frac{Q_1 Q_2}{r^2}}$$

where $\epsilon_0 = 8.85 \cdot 10^{-12} \cdot \frac{\text{C}^2}{\text{m}^2 \cdot \text{N}}$
 $\epsilon_0 = 8.85 \cdot 10^{-12} \cdot \frac{\text{As}}{\text{Vm}}$

1.4 Charge and Current

Learning Objectives

By the end of this section, you will be able to:

- distinguish the direction of conventional current and the flow of electrons.
- determine the cathode and anode of components
- apply the definition of current

What is Electric Charge and How Electricity Works

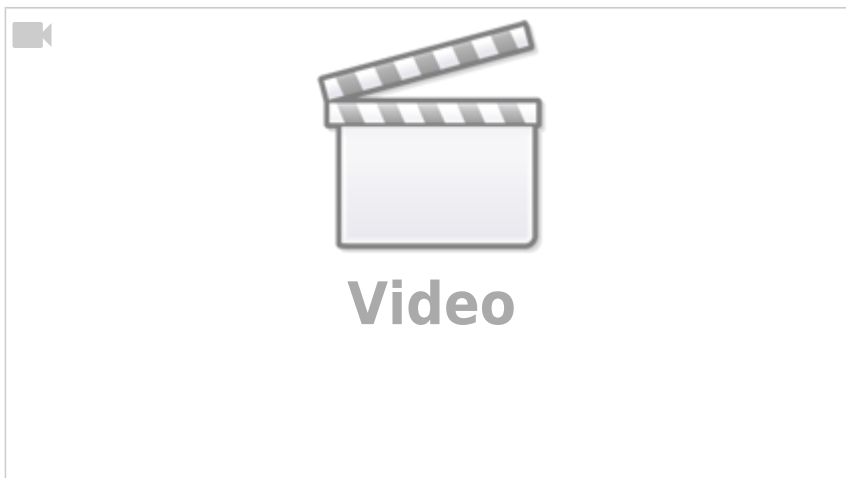

- From the previous experiments it is clear that there are two types of charge. In matter these are:
 - (+) \rightarrow excess of positive charges.
 - (-) \rightarrow excess of negative charges
- further experiment:
 - (+) and (-) are connected by a conductor
 - \rightarrow electrons move from (-)-pole to (+)-pole
 - \rightarrow electric current

Qualitative View

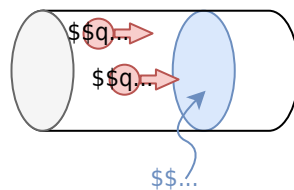

Fig. 11: Part of a Conductor

- In the thought experiment, let the following be given (see [figure 11](#)):
 - the above-mentioned conductor with a cross-section A perpendicular to the conductor
 - the quantity of charges $\Delta Q = n \cdot e \cdot \Delta t$, which in a certain period of time Δt , pass through the area A
- In the case of a uniform charge transport over a longer period, i.e. direct current (DC), the following applies:
 - The amount of charges per time flowing through the surface is constant:

$$\frac{\Delta Q}{\Delta t} = \text{const.} = I$$
 - I denotes the strength of the direct current.
 - The unit of I is the SI unit Ampere : $1 \text{ A} = \frac{1 \text{ C}}{1 \text{ s}}$. Thus, for the unit coulomb applies: $1 \text{ C} = 1 \text{ A} \cdot 1 \text{ s}$

Definition of current

The current of 1 A flows when an amount of charge of 1 C is transported in 1 s through the cross-section of the conductor.

Before 2019: The current of $1\text{~}\{\text{A}\}$ flows when two parallel conductors, each $1\text{~}\{\text{m}\}$ long and $1\text{~}\{\text{m}\}$ apart, exert a force of $F_{\text{L}} = 0.2 \cdot 10^{-6}\text{~}\{\text{N}\}$ on each other.

Note:

An electric current is the directed movement of free electric charge carriers.

Direction of the Current

Fig. 12: Part of a conductor with different charged charges

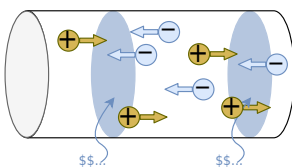

Charge transport can take place through (figure 12):

- negative charge carriers ΔQ_n (e.g. electrons in a metallic conductor).
- positive charge carriers ΔQ_p (e.g. certain semiconductor materials or in electrochemical cells)
- positive and negative charge carriers (e.g. certain semiconductor materials, plasma)

The total transported charge is $\Delta Q = \Delta Q_p - \Delta Q_n$

$$Q_n = n_p \cdot e - n_n \cdot (-e)$$

→ The direction of current must be determined independently of the direction of motion of the electric charge carriers.

Definition of current direction (according to DIN5489)

The current in a conductor from a cross-sectional area A_1 to a cross-sectional area A_2 is calculated positively, when:

- positive charge carriers move from A_1 to A_2 , resp
- negative charge carriers move from A_2 to A_1 .

The direction of the conventional current (or technical direction of current) is the direction of the positive current, i.e. the positive charge carriers.

Definition of electrodes (according to DIN5489)

An electrode is a connection (or pin) of an electrical component.

Looking at a component, the electrode is characterized as the homogenous part of the component, where the charges come in / move out (usually made out of metal).

The name of the electrode is given as follows:

- **Anode:** Electrode at which the current enters the component.
- **Cathode:** Electrode at which the current exits the component. (in German *Kathode*)

As a mnemonic, you can remember the diode's structure, shape, and electrodes (see [figure 13](#)).

Fig. 13: Electrodes on the diode

Exercises

Exercise E17 Electron flow

How many electrons pass through a control cross-section of a metallic conductor when the current of 40 mA flows for 4.5 s ?

Solution

$$\begin{align*} 1.1 \cdot 10^{18} \text{ electrons} \end{align*}$$

$$\begin{aligned} Q &= I \cdot t \quad \&= 0.04 \text{~}\{\text{A}\} \cdot 4.5 \text{~}\{\text{s}\} \quad \&= 0.18 \text{~}\{\text{As}\} \\ &= 0.18 \text{~}\{\text{C}\} \quad \&= \{0.18 \text{~}\{\text{C}\}\} \cdot \{1 \over 1.6022 \cdot 10^{-19}\} \{\text{C/electron}\} \\ &= 1.1 \cdot 10^{18} \text{~}\{\text{electrons}\} \end{aligned}$$

Exercise E18 Determining the Current from Charge per Time

Two objects experience a charge increase over time and the figure 14 shows the charge non-linearly as in the charge per time.

Result

A non-linear charge increase leads to a non-constant current.
 For a non-constant current, one has to use the time derivative of the charge Q to get the current I .
 So, the formula $I = \frac{dQ}{dt}$ has to be used instead of $I = \frac{\Delta Q}{\Delta t}$.

Fig. 14: Time course of the charge

1. Determine the currents I_1 and I_2 for the two objects from the Q - t -diagram figure 14 and plot the currents into a new diagram.

Solution

- Have a look how much increase ΔQ per time duration Δt is there for each object.
- For this choose a distinct time period, e.g. between $0\text{~}\mu\text{s}$ and $20\text{~}\mu\text{s}$.
- The current is then given as the change in charge per time: $I = \frac{\Delta Q}{\Delta t}$

Exercise E19 Electron flow

How many electrons pass through a control cross-section of a metallic conductor when the current of 40~mA flows for 4.5~s ?

Solution

$$\begin{aligned} & 1.1 \cdot 10^{18} \text{~}\mu\text{electrons} \end{aligned}$$

$$\begin{aligned} Q &= I \cdot t \quad \&= 0.04\text{~A} \cdot 4.5\text{~s} \quad \&= 0.18\text{~As} \\ &= 0.18\text{~C} \quad \&= \{0.18\text{~C}\} \cdot \left\{ \frac{1}{1.6022 \cdot 10^{-19}} \text{~}\mu\text{electron} \right\} \\ &= 1.1 \cdot 10^{18} \text{~}\mu\text{electrons} \end{aligned}$$

Exercise E20 Determining the Current from Charge per Time

Two objects experience a charge increase over time and the charge increase is non-linear. How can the current be determined, as per the charge per time?

Result

A non-linear charge increase leads to a non-constant current.
 For a non-constant current, one has to use the time derivative of the charge Q to get the current I .
 So, the formula $I = \frac{dQ}{dt}$ has to be used instead of $I = \frac{\Delta Q}{\Delta t}$.

Fig. 14: Time course of the charge ...

1. Determine the currents I_1 and I_2 for the two objects from the Q - t -diagram [figure 14](#) and plot the currents into a new diagram.

Solution

- Have a look how much increase ΔQ per time duration Δt is there for each object.
- For this choose a distinct time period, e.g. between 0 s and 20 s .
- The current is then given as the change in charge per time: $I = \frac{\Delta Q}{\Delta t}$

1.5 Voltage, Potential, and Energy

Learning Objectives

By the end of this section, you will be able to:

1. to determine the energy gain of a charge when overcoming a voltage difference.

Energetic Approach

Voltage vs Power vs Energy

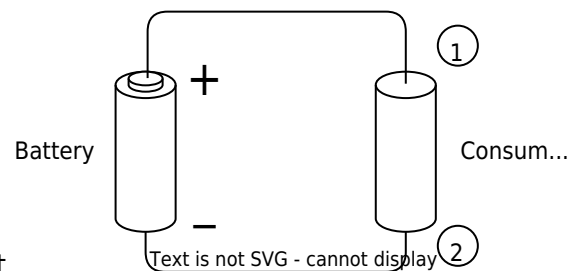
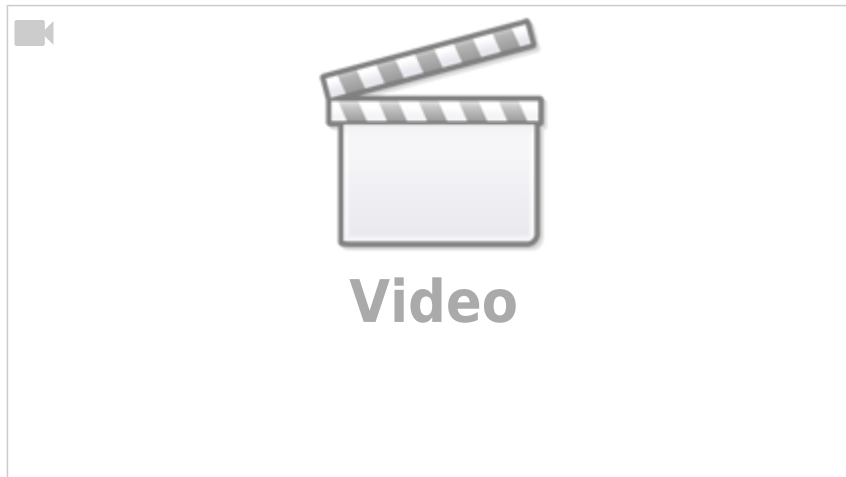

Fig. 16: Symbolic image of an electric circuit

Given is an electrical conductor (“consumer”) at a battery (see [figure 16](#))

- \rightarrow Current flows
- Similar to the transport of a mass in the gravitational field, energy is needed to transport the charge in the “voltage field”
- We will look at the specific electric field in the next semester
- A point charge q is moved from electrode ① to electrode ②.
The charge resembles a moving point of mass in the gravitational field.
- \rightarrow there is a turnover of energy.
- The energy turnover is proportional to the amount of charge q transported.
- In many cases, the “energetic path” from ① to ② has to be characterized in charge-independent terms:
$$\boxed{\frac{W_{1,2}}{q} = U_{1,2}}$$
- V for Voltage is in the English literature often used to denote the unit $\{\text{V}\}$ AS WELL AS the quantity V (in German U is used for the quantity):
- e.g.
 - $V_{CC} = 5 \sim \{\text{V}\}$: Voltage supply of an IC (Voltage Common Collector),
 - $V_{S+} = 15 \sim \{\text{V}\}$: Voltage supply of an operational amplifier (Voltage Supply plus).

Comparison: Mechanics vs Electrics

Fig. 17: Mechanical potential

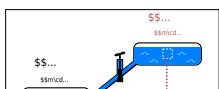

Mechanical System

Potential Energy

Potential energy is always related to a reference level (reference height). The energy required to move m from h_1 to h_2 is independent of the reference level.

$$\Delta W = W_1 - W_2 = m \cdot g \cdot (h_1 - h_2)$$

Fig. 18: Electrical Potential



Electrical System

Potential

The potential φ is always specified relative to a reference point.

Common used are:

- Earth potential (ground, earth, ground).
- infinitely distant point

To shift the charge, the potential difference must be overcome. The potential difference is independent of the reference potential. $\Delta W_{1,2} = W_1 - W_2 = Q \cdot \varphi_1 - Q \cdot \varphi_2 = Q \cdot (\varphi_1 - \varphi_2)$

Electric - Hydraulic Analogy: Charge, Voltage, and Current



V
i
d
e
o



It follows that:

$$\Delta W_{1,2} / Q = \varphi_1 - \varphi_2 = U_{1,2}$$

Note:

- Voltage is always a potential difference.
- The unit of voltage is V : $1 \sim \text{V}$

Definition of voltage

A voltage of $1 \sim \text{V}$ is present between two points if a charge of $1 \sim \text{C}$ undergoes an energy change of $1 \sim \text{J} = 1 \sim \text{Nm}$ between these two points.

From $W = U \cdot Q$ also the unit results: $1 \sim \text{Nm} = 1 \sim \text{V} \cdot \text{As}$
 $\rightarrow 1 \sim \text{V} = 1 \sim \frac{\text{Nm}}{\text{As}}$

Voltage between two Points

For the voltage between two points, using what we know so far, we get the following definition:

$$U_{12} = \varphi_1 - \varphi_2 = -U_{21} = -(\varphi_2 - \varphi_1)$$

Thus, the order of the indices must always be observed in the following.

Definition of the conventional direction of the voltage (according to DIN5489)

The voltage of U_{12} along a path from point ① to ② becomes positive when the potential in ① is greater than the potential in ②.

Exercises**Exercise E1.5.1 Direction of the voltage**

Fig. 19: Example of conventional voltage specification
Result

- + is the higher potential. Terminal 1 has the higher potential. $\varphi_1 > \varphi_2$
- For U_{Batt} : The arrow starts at terminal 1 and ends at terminal 2. So $U_{\text{Batt}} = U_{12} > 0$
- $U_{21} < 0$

Explain whether the voltages U_{Batt} , U_{12} and U_{21} in [figure 19](#) are positive or negative according to the voltage definition.

Hints

- Which terminal has the higher potential?
- From where to where does the arrow point?

1.6 Resistance and Conductance

Learning Objectives

By the end of this section, you will be able to:

- Know and be able to apply Ohm's law.
- calculate resistance from (specific) resistivity.
- determine the conductance from the resistance or the specific conductivity.
- know which cases of temperature dependence are distinguished and how they are named.
- calculate the resistance at different temperatures.
- know that there are different types of construction and that the physical value of the resistance does not depend on the geometric value.

Fig. 20: resistor as two-terminal component

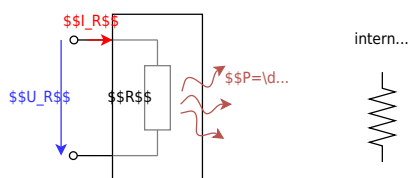

Current flow generally requires an energy input first. This energy is at some point extracted from the

electric circuit and is usually converted into heat. The reason for this conversion is the resistance e.g. of the conductor or other loads.

A resistor is an electrical component with two connections (or terminals). Components with two terminals are called two-terminal networks or one-port networks ([figure 20](#)). Later in the semester, four-terminal networks will also be added.

In general, the cause-and-effect relationship is such that an applied voltage across the resistor produces the current flow. However, the reverse relationship also applies: as soon as an electric current flows across a resistor, a voltage drop is produced over the resistor. In electrical engineering, circuit diagrams use idealized components in a [Lumped-element model](#). The resistance of the wires is either neglected - if it is very small compared to all other resistance values - or drawn as a separate “lumped” resistor.

The values of the resistors are standardized in such a way, that there is a fixed number of different values between $1\ \Omega$ and $10\ \Omega$ or between $10\ \text{k}\Omega$ and $100\ \text{k}\Omega$. These ranges, which cover values up to the tenfold number, are called decades. In general, the resistors are ordered in the so-called [E series of preferred numbers](#), like 6 values in a decade, which is named E6 (here: $1.0\ \text{k}\Omega$, $1.5\ \text{k}\Omega$, $2.2\ \text{k}\Omega$, $3.3\ \text{k}\Omega$, $4.7\ \text{k}\Omega$, $6.8\ \text{k}\Omega$). As higher the number (e.g. E24) more different values are available in a decade, and as more precise the given value is.

For larger resistors with wires, the value is coded by four to six colored bands (see [conversion tool](#)). For smaller resistors without wires, often numbers are printed onto the components ([conversion tool](#))

Fig. 21: examples for a real 15kOhm resistor

Linearity of Resistors

Linear Resistors

Fig. 21: Linear resistors in the U-I diagram

Non-linear Resistors

Fig. 23: Non-linear resistors in the U-I diagram



- For linear resistors, the resistance value is $R = \frac{U_R}{I_R} = \text{const.}$ and thus independent of U_R .
- **Ohm's law** results: $R = \frac{U_R}{I_R}$ with unit $[R] = \frac{[U_R]}{[I_R]} = 1 \text{ } \Omega$
- In [figure 21](#) the value R can be read from the course of the straight line $R = \frac{\Delta U_R}{\Delta I_R}$
- The reciprocal value (inverse) of the resistance is called the conductance: $G = \frac{1}{R}$ with unit $1 \text{ } \text{S}$ ($1 \text{ } \text{Siemens}$). This value can be seen as a slope in the U - I diagram.

- The point in the U - I diagram in which a system rests is called the operating point. In the [figure 23](#) an operating point is marked with a circle in the left diagram.
- For nonlinear resistors, the resistance value is $R = \frac{U_R}{I_R(U_R)} = f(U_R)$. This resistance value depends on the operating point.
- Often small changes around the operating point are of interest (e.g. for small disturbances of load machines). For this purpose, the differential resistance r (also dynamic resistance) is determined: $r = \frac{dU_R}{dI_R} \approx \frac{\Delta U_R}{\Delta I_R}$ with unit $[R] = 1 \text{ } \Omega$.
- As with the resistor R , the reciprocal of the differential resistance r is the differential conductance g .
- In [figure 23](#) the differential conductance g can be read from the slope of the straight line at each point $g = \frac{dI_R}{dU_R}$

Resistance as a Material Property

Good explanation of resistivity

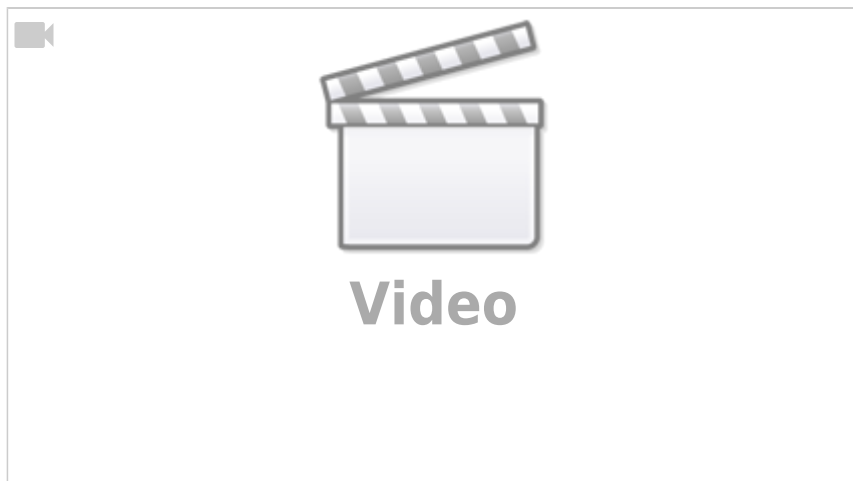

The value of the resistance can also be derived from the geometry of the resistor. For this purpose, an experiment can be carried out with resistors of different shapes. Thereby it can be stated:

- the resistance R increases proportionally with the distance l the current has to travel: $R \sim l$
- the resistance R decreases inversely proportional with the cross-sectional area A through which the current passes: $R \sim \frac{1}{A}$
- the resistance R depends on the material (table 5)
- thus one obtains:
 $R \sim \frac{l}{A}$

Material	ρ in $\frac{\Omega \cdot \text{mm}^2}{\text{m}}$
Silver	$1.59 \cdot 10^{-2} \Omega \cdot \text{mm}^2/\text{m}$
Copper	$1.79 \cdot 10^{-2} \Omega \cdot \text{mm}^2/\text{m}$
Gold	$2.2 \cdot 10^{-2} \Omega \cdot \text{mm}^2/\text{m}$
Aluminium	$2.78 \cdot 10^{-2} \Omega \cdot \text{mm}^2/\text{m}$
Lead	$2.1 \cdot 10^{-1} \Omega \cdot \text{mm}^2/\text{m}$
Graphite	$8 \cdot 10^0 \Omega \cdot \text{mm}^2/\text{m}$
Battery Acid (Lead-acid Battery)	$1.5 \cdot 10^4 \Omega \cdot \text{mm}^2/\text{m}$
Blood	$1.6 \cdot 10^6 \Omega \cdot \text{mm}^2/\text{m}$
(Tap) Water	$2 \cdot 10^7 \Omega \cdot \text{mm}^2/\text{m}$
Paper	$1 \cdot 10^{15} \dots 1 \cdot 10^{17} \Omega \cdot \text{mm}^2/\text{m}$

Tab. 5: Specific resistivity for different materials

Note:

The resistance can be calculated by $R = \rho \cdot \frac{l}{A}$

- ρ is the material dependent resistivity with the unit:
 $[\rho] = \frac{[R] \cdot [A]}{[l]} = 1 \sim \frac{\Omega \cdot \text{mm}^2}{\text{m}} = 1 \sim \Omega \cdot \text{mm}$
- Often, instead of $1 \sim \Omega \cdot \text{mm}$, the unit $1 \sim \frac{\Omega \cdot \text{mm}^2}{\text{m}}$ is used. It holds that $1 \sim \frac{\Omega \cdot \text{mm}^2}{\text{m}} = 10^{-6} \sim \Omega \cdot \text{mm}$

- There exists also a specific conductance κ , given by the conductance G :
 $G = \kappa \cdot \frac{A}{l}$
- The specific conductance κ is the reciprocal of the specific resistance ρ :
 $\kappa = \frac{1}{\rho}$

Temperature Dependence of Resistors

Explanation of the temperature dependence of resistors

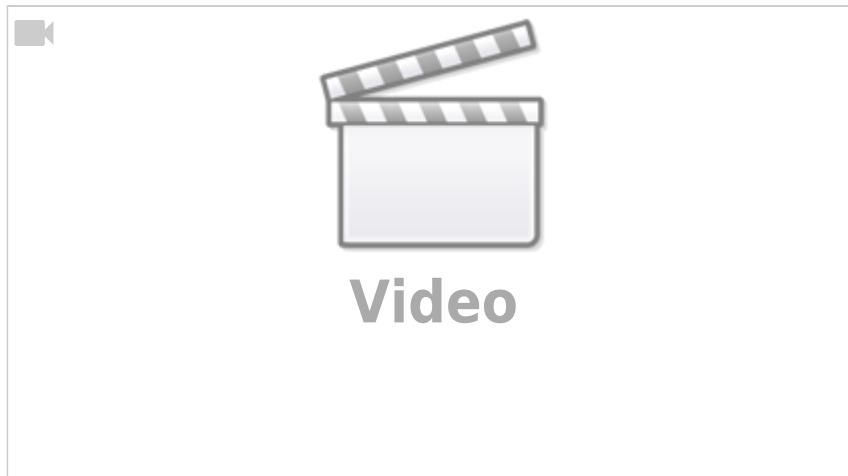

The resistance value is - apart from the influences of geometry and material mentioned so far - also influenced by other effects. These are e.g.:

- Heat (thermoresistive effect, e.g. in the resistance thermometer)
- Light (photosensitive effect, e.g. in the component photoresistor)
- Magnetic field (magnetoresistive effect, e.g. in hard disks)
- Pressure (piezoresistive effect e.g. tire pressure sensor)
- Chemical environment (chemoresistive effect e.g. chemical analysis of breathing air)

To summarize these influences in a formula, the mathematical tool of [Taylor series](#) is often used. This will be shown here practically for the thermoresistive effect. The thermoresistive effect, or the temperature dependence of the resistivity, is one of the most common influences in components.

The starting point for this is again an experiment. The ohmic resistance is to be determined as a function of temperature. For this purpose, the resistance is measured using a voltage source, a voltmeter (voltage measuring device), and an ammeter (current measuring device), and the temperature is changed ([figure 24](#)).

Fig. 24: Circuit for measuring the effect of temperature on a resistor

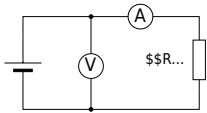

The result is a curve of the resistance R versus the temperature ϑ as shown in [figure 25](#). As a first approximation is a linear progression around an operating point. This results in:

$$R(\vartheta) = R_0 + c \cdot (\vartheta - \vartheta_0)$$

- The constant is replaced by $c = R_0 \cdot \alpha$
- α here is the linear temperature coefficient with unit: $[\alpha] = \frac{1}{\vartheta} = \frac{1}{\text{K}}$
- Besides the linear term, it is also possible to increase the accuracy of the calculation of $R(\vartheta)$ with higher exponents of the temperature influence. This approach will be discussed in more detail in the mathematics section below.
- These temperature coefficients are described with Greek letters: α , β , γ , ...
- Sometimes in the datasheets the value α is named as TCR (“Temperature Coefficient of Resistance”), for example [here](#).

Fig. 25: Influence of temperature on resistance

**Note:**

Fig. 26: Influence of temperature on resistance



The temperature dependence of the resistance is described by the following equation:

$$\boxed{R(\vartheta) = R_0 (1 + \alpha \cdot (\vartheta - \vartheta_0) + \beta \cdot (\vartheta - \vartheta_0)^2 + \gamma \cdot (\vartheta - \vartheta_0)^3 + \dots)}$$

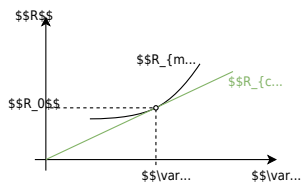
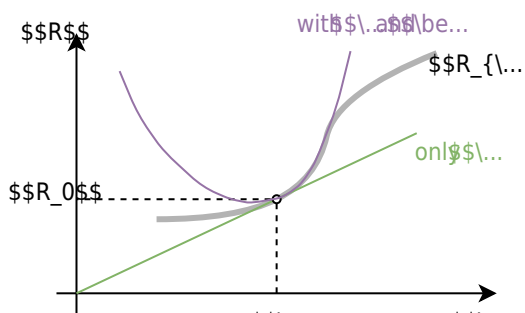
Where:

- α the (linear) temperature coefficient with unit: $[\alpha] = \frac{1}{\text{K}}$
- β the (quadratic) temperature coefficient with unit: $[\beta] = \frac{1}{\text{K}^2}$
- γ the temperature coefficient with unit: $[\gamma] = \frac{1}{\text{K}^3}$
- ϑ_0 is the given reference temperature, usually 0°C or 25°C .

The further the temperature range deviates from the reference temperature, the more temperature coefficients are required to reproduce the actual curve (figure 26).

Outlook

In addition to the specification of the parameters α, β, \dots , the specification of R_{25} and B_{25} can occasionally be found. This is a different variant of approximation, which refers to the temperature of 25°C . It is based on the [Arrhenius equation](#), which links reaction kinetics to temperature in chemistry. For the temperature dependence of the resistance, the Arrhenius equation links the inhibition of carrier motion by lattice vibrations to the temperature $R(T) \sim \text{e}^{\frac{B}{T}}$.

A series expansion can again be applied: $R(T) \sim \text{e}^{\frac{A}{T} + \frac{B}{T} + \frac{C}{T^2} + \dots}$.

However, often only B is given, for example [here](#).

By taking the ratio of any temperature T and $T_{25} = 298.15\text{K}$ (25°C) we get: $\frac{R(T)}{R_{25}} = \frac{\exp\left(\frac{B}{T}\right)}{\exp\left(\frac{B}{298.15\text{K}}\right)}$ with $R_{25} = R(T_{25})$

This allows the final formula to be determined: $R(T) = R_{25} \cdot \exp\left(\frac{B}{T} - \frac{B}{298.15\text{K}}\right)$

Types of temperature-dependent Resistors

Besides the temperature dependence as a negative, disturbing influence, some components have been deliberately developed for a specific temperature influence. These are called thermistors (a portmanteau of thermally sensitive resistor). Thermistors are divided into hot conductors and cold conductors.

A special form of thermistors is materials that have been explicitly optimized for minimum temperature dependence (e.g. Constantan or Isohm).

NTC Thermistor

- As the name suggests, the NTC has a negative temperature coefficient. This leads to lower resistance at higher temperatures.
- Such an NTC thermistor is also called *Heißleiter* in German (“hot conductor”).
- Examples are semiconductors
- Applications are inrush current limiters and temperature sensors. For the desired operating point, a strongly non-linear curve is selected there (e.g. fever thermometer).

Fig. 27: NTC thermistor in the U-I-diagram



PTC Thermistor

- As the name suggests, the PTC has a positive temperature coefficient. This leads to lower resistance at lower temperatures.
- Such a PTC thermistor is also called *Kaltleiter* in German (“cold conductor”).
- Examples are doped semiconductors or metals.
- Applications are temperature sensors. For this purpose, they often offer a wide temperature range and good linearity (e.g. PT100 in the range of $-100\sim^{\circ}\{\mathrm{r}m\mathrm{C}\}$ to $200\sim^{\circ}\{\mathrm{r}m\mathrm{C}\}$).
- [Interactive example](#) for PTC thermistors

Fig. 28: PTC thermistor in the U-I diagram



Resistor Packages

The packages are not explained in detail here. The video shows the smaller available packages. In the 3rd semester and higher we will use 0603-size resistors.

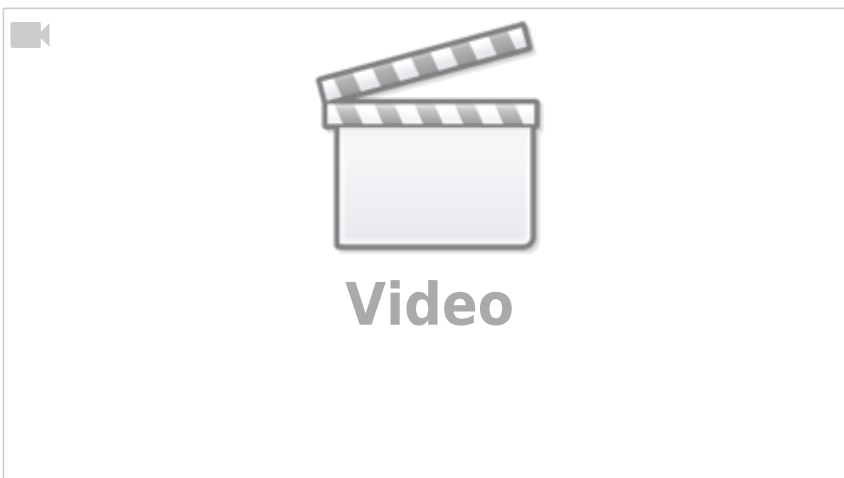

Exercises

Exercise 1.6.1 Pre-calculated example of resistivity

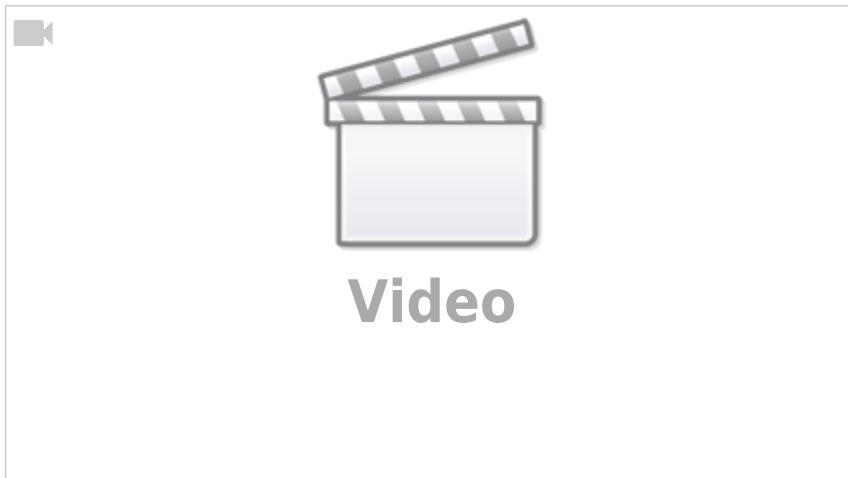

Exercise 1.6.2 Resistance of a pencil stroke

Assume that a soft pencil lead is 100% graphite. What is the resistance of a 5.0 cm long and 0.20 mm wide line if it has a height of $0.20\text{ }\mu\text{m}$?

The resistivity is given by [table 5](#).

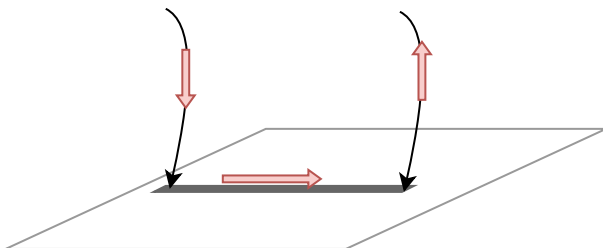

Final result

$$\begin{aligned} R &= 10\text{ k}\Omega \end{aligned}$$

Exercise 1.6.3 Resistance of a cylindrical coil

Let a cylindrical coil in the form of a multi-layer winding be given - this could for example occur in windings of a motor. The cylindrical coil has an inner diameter of $d_i = 70\text{ mm}$ and an outer diameter of $d_a = 120\text{ mm}$. The number of turns is $n_W = 1350$ turns, the wire diameter is $d = 2.0\text{ mm}$ and the specific conductivity of the wire is $\kappa_{\text{Cu}} = 56 \cdot 10^6 \frac{\text{S}}{\text{m}}$.

First, calculate the wound wire length and then the ohmic resistance of the entire coil.

Exercise 1.6.4 Resistance of a supply line

The power supply line to a consumer has to be replaced. Due to the application, the conductor resistance must remain the same.

- The old aluminium supply cable had a specific conductivity $\kappa_{\text{Al}} = 33 \cdot 10^6 \text{ S/m}$ and a cross-section $A_{\text{Al}} = 115 \text{ mm}^2$.
- The new copper supply cable has a specific conductivity $\kappa_{\text{Cu}} = 56 \cdot 10^6 \text{ S/m}$

Which wire cross-section A_{Cu} must be selected?

Exercise 1.6.5 Strain gauges

t.b.d.

Exercise 1.6.6: Temperature-dependent resistance of a winding (written test, approx. 6 % of a 60-minute written test, WS2020)

On the rotor of an asynchronous motor, the windings are designed in copper. The length of the winding wire is 40 m . The diameter is 0.4 mm . When the motor is started, it is uniformly cooled down to the ambient temperature of 20°C . During operation the windings on the rotor have a temperature of 90°C .

$$\alpha_{\text{Cu}, 20^\circ \text{C}} = 0.0039 \text{ K}^{-1}$$

$$\beta_{\text{Cu}, 20^\circ \text{C}} = 0.6 \cdot 10^{-6} \text{ K}^{-2}$$

$$\rho_{\text{Cu}, 20^\circ \text{C}} = 0.0178 \frac{\Omega \text{ mm}^2}{\text{m}}$$

Use both the linear and quadratic temperature coefficients! 1. determine the resistance of the wire for $T = 20^\circ \text{C}$.

Solution

$$\begin{aligned} R_{20^\circ \text{C}} &= \rho_{\text{Cu}, 20^\circ \text{C}} \cdot \frac{l}{A} \quad | \text{with} \\ A &= r^2 \cdot \pi = \frac{1}{4} d^2 \cdot \pi \quad | \\ R_{20^\circ \text{C}} &= \rho_{\text{Cu}, 20^\circ \text{C}} \cdot \frac{4 \cdot l}{d^2 \cdot \pi} \quad | \\ &= 0.0178 \frac{\Omega \text{ mm}^2}{\text{m}} \cdot \frac{4 \cdot 40 \text{ m}}{(0.4 \text{ mm})^2 \cdot \pi} \quad | \end{aligned}$$

Final result

$$R_{20^\circ \text{C}} = 5.666 \Omega \rightarrow 5.7 \Omega$$

2. what is the increase in resistance ΔR between 20°C and 90°C for one winding?

Solution

$$\begin{aligned} R_{90^\circ \text{C}} &= R_{20^\circ \text{C}} \cdot (1 + \alpha_{\text{Cu}, 20^\circ \text{C}} \cdot \Delta T + \beta_{\text{Cu}, 20^\circ \text{C}} \cdot \Delta T^2) \quad | \text{with } \Delta T = T_2 - T_1 = \end{aligned}$$

$$90\text{~}^\circ\text{C} - 20\text{~}^\circ\text{C} = 70\text{~}^\circ\text{C} = 70\text{~}\text{K} \\ \Delta R \approx R_{20^\circ\text{C}} \cdot (\alpha_{\text{Cu}, 20^\circ\text{C}} \cdot \Delta T + \beta_{\text{Cu}, 20^\circ\text{C}} \cdot \Delta T^2) \\ \Delta R \approx 5.666\ \Omega \cdot (0.0039 \cdot \frac{1}{\text{K}} \cdot 70\text{~}\text{K} + 0.6 \cdot 10^{-6} \cdot \frac{1}{\text{K}^2} \cdot (70\text{~}\text{K})^2)$$

Final result

$$\Delta R \approx 1.56\ \Omega \rightarrow 1.6\ \Omega$$

1.7 Power and Efficiency

Learning Objectives

After this lesson you should be able to:

1. Be able to calculate the electrical power and energy across a resistor.

A nice 10-minute intro into power and efficiency (a cutout from 2:40 to 12:15 from a full video of EEVblog)

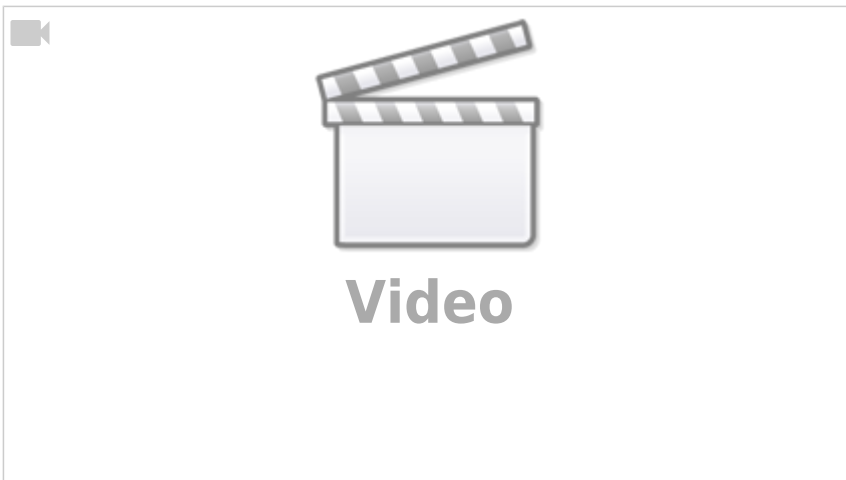

Determining the electrical Power in a DC Circuit

From chapter [1.5 Voltage, potential, and energy](#) it is known that a movement of a charge across a potential difference corresponds to a change in energy. Charge transport therefore automatically means energy expenditure. Often, however, the energy expenditure per unit of time is of interest.

Fig. 29: Course of power and energy

SSSSSS

Fig. 30: Source and consumer

The energy expenditure per time unit represents the **power**:

$\boxed{P = \frac{\Delta W}{\Delta t}}$ with the unit $[P] = \frac{[W]}{[t]} = \frac{\text{Nm}}{\text{s}} = \text{W}$

For a constant power P and an initial energy $W(t=0) = 0$ holds:

$\boxed{W = P \cdot t}$

If the above restrictions do not apply, the generated/needed energy must be calculated via an integral.

Besides the current flow from the source to the consumer (and back), also power flows from the source to the consumer. In the following circuit, the color code shows the incoming and outgoing power.

If we only consider a DC circuit, the following energy is converted between the terminals (see also [figure 29](#) and [figure 30](#)):

$$W = U_{12} \cdot Q = U_{12} \cdot I \cdot t$$

This gives the power (i.e. energy converted per unit time):

$$P = U_{12} \cdot I \quad \text{with the unit } [P] = 1 \text{ V} \cdot \text{A} = 1 \text{ W} \quad \dots \quad \text{W}$$

here stands for the physical unit watts.

For ohmic resistors:

$$P = R \cdot I^2 = \frac{U_{12}^2}{R}$$

Nominal Quantities of ohmic Loads

Name of the nominal quantity	physical quantity	description
Nominal power (= rated power)	P_{N}	P_{N} is the power output of a device (consumer or generator) that is permissible in continuous operation.
Nominal current (= rated current)	I_{N}	I_{N} is the current occurring during operation at rated power.
Nominal voltage (= rated voltage)	U_{N}	U_{N} is the voltage occurring during operation at rated power.

Efficiency

The usable (= outgoing) P_{O} power of a real system is always smaller than the supplied (incoming) power P_{I} . This is due to the fact, that there are additional losses in reality. The difference is called power loss P_{loss} . It is thus valid:

$$P_{\text{I}} = P_{\text{O}} + P_{\text{loss}}$$

Instead of the power loss P_{loss} , the efficiency η is often given:

$$\eta = \frac{P_{\text{O}}}{P_{\text{I}}} < 1$$

For systems connected in series (cf. [figure 31](#)), the total resistance is given by:

$$\eta = \frac{P_{\text{O}}}{P_{\text{I}}} = \frac{P_{\text{O}_1}}{P_{\text{I}_1}} \cdot \frac{P_{\text{O}_2}}{P_{\text{I}_2}} \cdot \frac{P_{\text{O}_3}}{P_{\text{I}_3}} = \eta_1 \cdot \eta_2 \cdot \eta_3$$

Fig. 31: Power flow diagram

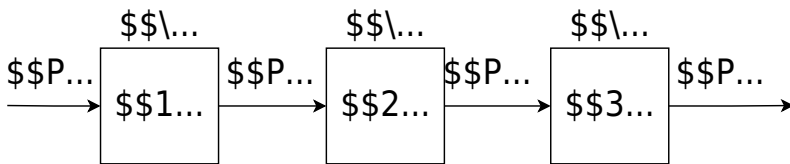

Exercises

Exercise 1.7.1 Pre-calculated example of electrical power and energy

The first 5:20 minutes is a recap of the fundamentals of calculating the electric power

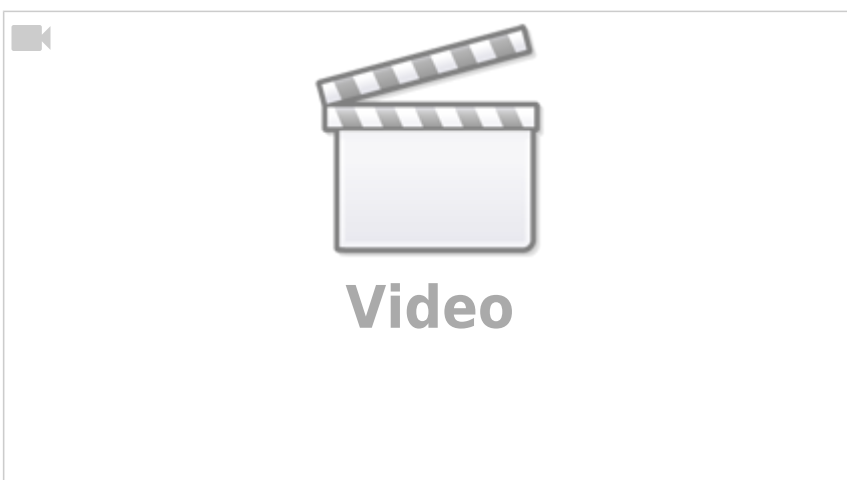

Exercise E1.7.2 Power

An SMD resistor is used on a circuit board for current measurement. The resistance value should be $R=0.20\ \Omega$, and the maximum power $P_M=250\ \text{mW}$. What is the maximum current that can be measured?

Solution:
$$I = 1.118... \text{ A} \rightarrow I = 1.12 \text{ A}$$

The formulas $R = \frac{U}{I}$ and $P = U \cdot I$ can be combined to get:

$$P = R \cdot I^2$$

This can be rearranged into

$$I = \sqrt{\frac{P}{R}}$$

Exercise 1.7.3 Power loss and efficiency I

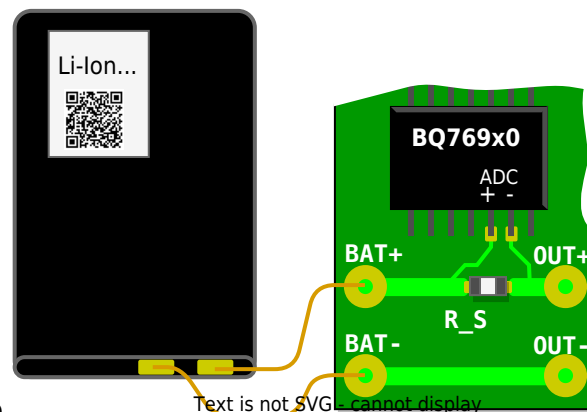

Fig. 32: Sketch of the setup

- The battery monitor BQ769x0 measures the charge and discharge currents of a lithium-ion battery using the voltage across a measuring resistor (shunt). In figure 32 the analog-to-digital converter (ADC) of this chip is connected to the shunt R_S via the circuit board. Through the shunt, the discharge current flows from the battery connection BAT+ to OUT+ and via OUT- back to BAT- . The shunt shall be designed so that the bipolar measurement signals have a voltage level in the range of $-0.20\ \text{V}$ to $+0.20\ \text{V}$. The analog-to-digital converter has a resolution of $15\ \mu\text{V}$. The currents can be used to count the charge in the battery to determine the state of charge (SOC).
- Draw an equivalent circuit with a voltage source (battery), measuring resistor and load resistor R_L . Also, draw the measurement voltage and load voltage.
- The shunt should have a resistance value of $1\ \text{m}\Omega$. What maximum charge/discharge currents are still measurable? What minimum current change is measurable?

- What power loss is generated at the shunt in the extreme case?
- Now the efficiency is to be calculated
 - Find the efficiency as a function of R_S and R_L . Note that the same current flows through both resistors.
 - Special task: The battery is to have a nominal voltage of 10 V (3 cells) and the maximum discharge current is to flow. What efficiency results from the measurement alone?

Exercise 1.7.4 Power loss and efficiency II

A water pump ($\eta_P = 60\%$) has an electric motor drive ($\eta_M = 90\%$). The pump has to pump 500 l water per minute up to 12 m difference in height.

- What must be the rated power of the motor?
- What current does the motor draw from the 230 V mains? (assumption: the 230 V is a DC value and also the current is DC)

Exercise 1.7.5 PPTC

Often, parts of a circuit have to be protected from over-current, since otherwise, components could break. This is usually done by a fuse or a circuit breaker, which opens up the connection and therefore disables the path for the current. A problem with the commonly used fuses is, that once the fuse is blown (=it has been tripped) it has to be changed.

Since opening up electronics and changing the fuse is not reasonable for consumer electronics, these products nowadays use [resettable fuses](#). These consist of a polymer (=“plastics”) with conducting paths of graphite or carbon black in it. When more and more current is flowing, more and more heat is generated. At one distinct temperature, the polymer expands rapidly - which is also called phase change. This expansion moves the conducting paths apart. The system will stay in a state, where a minimum current is flowing, which maintains just enough heat dissipation for the expansion. This process is also reversible: When cooled down, the conducting paths get re-connected. These components are also called **polymer positive temperature coefficient** components or PPTC.

In the diagram below the internal structure and the resistance over the temperature are shown (more details about the structure and function can be found [here](#)).

\$...↑



In the given circuit below, a fuse F shall protect another component shown as R_{L} , which could be a motor or motor driver for example. In general, the fuse F can be seen as a (temperature variable) resistance. The source voltage U_{S} is $50\text{~}\{\text{V}\}$ and $R_{\text{L}}=250\text{~}\Omega$.

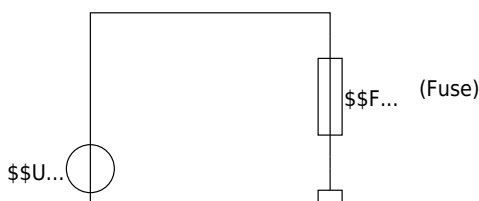

For this fuse, the component “[OZCG0020AF2C](#)”¹⁾ is used. When this fuse trips, it has to carry nearly the full source voltage and dissipates a power of 0.8 W .

- First assume that the fuse is not blown. The resistance of the fuse at this is $1 \text{ }\Omega$, which is negligible compared to R_{L} . What is the value of the current flowing through R_{L} ?
- Assuming for the next questions that the fuse has to carry the full source voltage and the given power is dissipated.
 - Which value will the resistance of the fuse have?
 - What is the current flowing through the fuse, when it is tripped?
 - Compare this resistance of the fuse with R_{L} . Is the assumption, that all of the voltage drops on the fuse feasible?

Further Reading

1. [Omega Tau Nr. 303](#): German Podcast with a researcher from the BTP ([Physikalisch-Technische Bundesanstalt](#), Germany's national standardization institute) on the evolution of the SI unit system.
2. [How electric flow really works](#): No, there are no free electrons in the wire, and the electrons are not colliding with the atoms or atomic cores...

1)

the datasheet is not needed for this exercise

From:

<https://wiki.mexle.org/> - **MEXLE Wiki**

Permanent link:

https://wiki.mexle.org/electrical_engineering_and_electronics_1/preparation_properties_proportions

Last update: **2024/10/10 15:17**

