

# Exam Summer Semester 2023

## Student Group

First Name	Surname	Matrikel Nr.

## Table of Contents

**Exam Summer Semester 2023** ..... 2

    Additional permitted Aids ..... 2

    Hits ..... 2

    Tasks ..... 2

        Exercise E1 Resistivity and temperature dependent Resistance (written test, approx. 7 % of a 60-minute written test, SS2023) ..... 2

        Exercise E1 Analyzing a Scope Plot (written test, approx. 12 % of a 60-minute written test, SS2023) ..... 3

        Exercise E2 Complex voltage dividers (written test, approx. 16 % of a 60-minute written test, SS2023) ..... 4

        Exercise E1 Pure Resistor Network Simplification (written test, approx. 12 % of a 60-minute written test, SS2023) ..... 5

        Exercise E1 Pure Resistor Network Simplification I (written test, approx. 14 % of a 60-minute written test, SS2023) ..... 7

        Exercise E2 Equivalent Linear Source (written test, approx. 10 % of a 60-minute written test, SS2023) ..... 10

        Exercise E1 (Dis)Charging Capacities (written test, approx. 14 % of a 60-minute written test, SS2023) ..... 13

        Exercise E3 Impedances at Frequencies (written test, approx. 14 % of a 60-minute written test, SS2023) ..... 14

        Exercise E1 Efficiency (written test, approx. 14 % of a 60-minute written test, SS2023) ..... 15

# Exam Summer Semester 2023

## Additional permitted Aids

- non-programmable calculator,
- formulary (2 DIN A4 pages)

## Hits

- The duration of the exam is 60 min.
- Attempts to cheat will lead to exclusion and failure of the exam.
- Withdrawal is no longer possible after these exam has been handed out.
- Please write down intermediate calculations and results on the assignment sheet. (when more space is needed also on the reverse side. In this case: Mark it clearly).
- Always use units in the calculation.
- Use a document-proof, non-red pen.

## Tasks

### Exercise E1 Resistivity and temperature dependent Resistance (written test, approx. 7 % of a 60-minute written test, SS2023)

The resistivity  $\rho$  of a dielectric material is temperature dependent and is described by the Arrhenius law in an exponential form as  $\rho = \rho_0 \cdot \exp(\alpha \cdot T + \beta \cdot T^2)$  for  $T$  between 20 °C and 55 °C.

The resistivity of the dielectric material is  $\rho(20 \text{ °C}) = 10^{17} \text{ } \Omega \cdot \text{m}$ .

For the given material the temperature coefficients in the range 20 °C and 55 °C are given as  $\alpha = -0.048 \text{ } 1/\text{K}$  and  $\beta = +0.00057 \text{ } 1/\text{K}^2$ .

$$\begin{aligned} \rho(55 \text{ °C}) &= \rho(20 \text{ °C}) \cdot (1 + \alpha \cdot \Delta T + \beta \cdot T^2 + \dots) \\ &= 10^{17} \text{ } \Omega \cdot \text{m} \cdot (1 - 0.048 \text{ } 1/\text{K} \cdot (35 \text{ K}) + 0.00057 \text{ } 1/\text{K}^2 \cdot (35 \text{ K})^2) \end{aligned}$$

Calculate the resistance for the dielectric material for  $20 \text{ }^\circ\text{C}$ .

Solution

$$R(20 \text{ }^\circ\text{C}) = \rho \cdot \frac{d}{A} = 10^{17} \frac{\Omega \cdot \text{m}}{0.8 \cdot 10^{-6} \text{ m}} \cdot \frac{1 \text{ m}}{1 \text{ m}^2}$$

**Exercise E1 Analyzing a Scope Plot**  
**(written test, approx. 12 % of a 60-minute written test, SS2023)**

0. What is the RMS value of a sine wave with a peak-to-peak value of 10 V and a phase shift of 45 degrees? (in degrees and degree)?  
 Result: The measured current curve shall be visible as a dashed line.

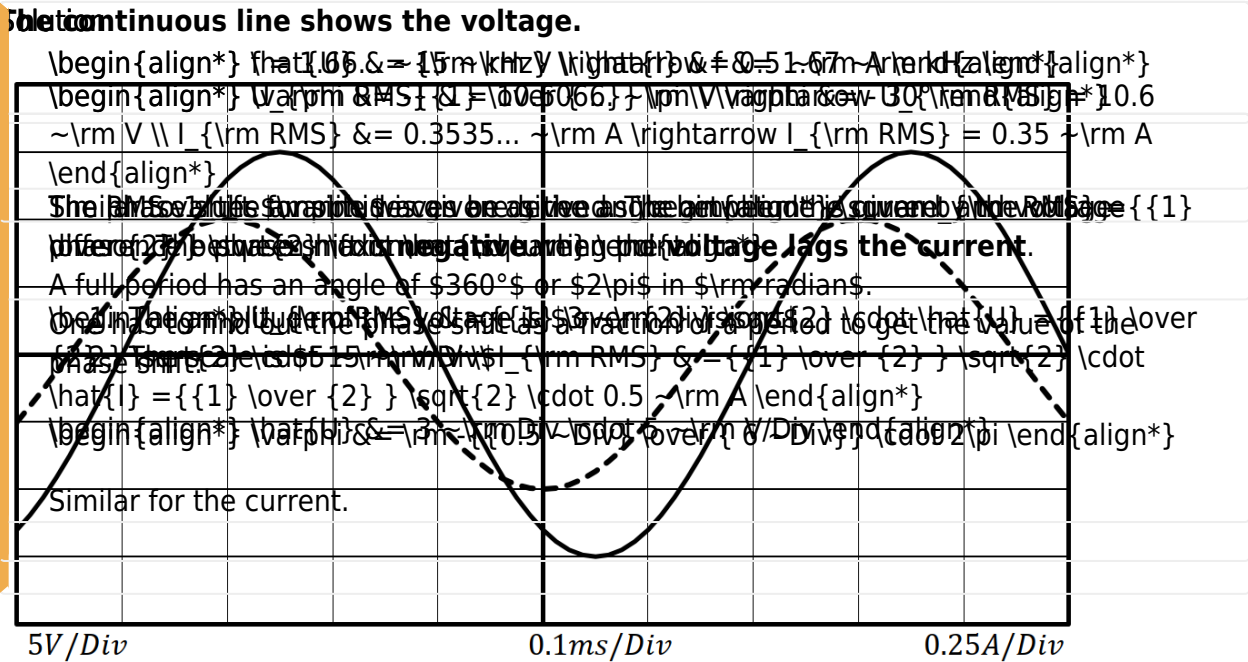

Use the correct symbols and units in your answers!

1. Calculate the frequency  $f$  of the periodic signals.

Solution

Frequency  $f$  is given by the period  $T$ . The period can be measured in the image of the scope.

1. The sine waves repeat after  $6 \text{ divisions}$  (e.g. from falling turning point to falling turning point of one curve)
2. The scale is  $0.1 \text{ ms/Div}$

$$f = \frac{1}{T} \quad T = 6 \text{ Div} \cdot 0.1 \text{ ms/Div}$$

$$\Rightarrow f = \frac{1}{6 \text{ Div} \cdot 0.1 \text{ ms/Div}}$$

**Exercise E2 Complex voltage dividers**  
 (written test, approx. 16 % of a 60-minute written test, SS2023)

Calculate the two impedances  $Z_1$  and  $Z_2$  in the following circuit for the voltage divider. Choose an appropriate scaling factor and write it down.

- $R = 1.1 \text{ k}\Omega$

Solution  $I = 3.5 \text{ mA}$

**Solution**

$$U = 5 \text{ V}$$

$$I = 3.5 \text{ mA}$$

$$\underline{U}_O = 0.5 \cdot \underline{U}_I$$

The formula to start with is the (complex) voltage divider:  $\underline{U}_O = \underline{U}_I \cdot \frac{Z_L}{Z_L + Z_S}$ .  
 And if we know the absolute values of impedances  $Z_L$  and  $Z_S$  in equation  $\underline{U}_O = \underline{U}_I \cdot \frac{Z_L}{Z_L + Z_S}$ , this leads to  $\frac{U_O}{U_I} = \frac{|Z_L|}{|Z_L + Z_S|}$ .  
 $\frac{10^{-3}}{10^{-3}} = \frac{|Z_L|}{|Z_L + Z_S|}$   $\Rightarrow |Z_L| = |Z_L + Z_S|$   $\Rightarrow |Z_L| = |Z_L + j\omega L|$   
 $\Rightarrow |Z_L| = \sqrt{R^2 + (\omega L)^2}$   $\Rightarrow R^2 = (\omega L)^2$   $\Rightarrow R = \omega L$   $\Rightarrow R = 2\pi \cdot 150 \cdot 3.5 \cdot 10^{-3}$   $\Rightarrow R = 3.297 \text{ } \Omega$

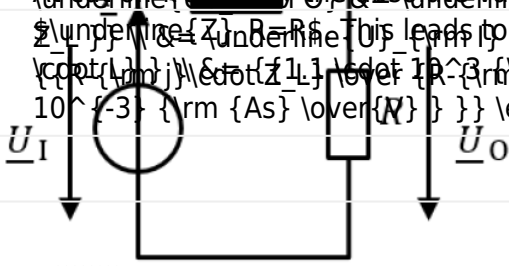

.. Calculate the impedance  $\underline{Z}_L$ .

Solution

$$\underline{Z}_L = j\omega L = j \cdot 2\pi \cdot 150 \text{ kHz} \cdot 3.5 \text{ mH}$$

**Exercise E1 Pure Resistor Network Simplification**  
 (written test, approx. 12 % of a 60-minute written test, SS2023)

Calculate the voltage  $U_K$ , when switch  $S$  is closed.

Result

The values in the circuit are

Solution

- $R_1 = 60 \text{ } \Omega$
  - $R_2 = 40 \text{ } \Omega$
  - $R_3 = 40 \text{ } \Omega$
- The voltage divider  $U_K$  has the same proportionality as the voltage divider  $U_A$ . Therefore, the potential of  $K$  is the same as for  $A$ . There will be no current flow through  $R_3$ . The resistance does not create a voltage drop and therefore does not interfere with the circuit.

1. Calculate the voltage at node  $K$ , when switch  $S$  is open. It might be beneficial to redraw the circuit first.

Solution

Rearranging the circuit one can get:

Once the switch  $S$  is opened, the upper part is a parallel circuit. Therefore,  $R_{\text{eq}}$  is given as:

$$R_{\text{eq}} = (R_1 + R_2) \parallel (R_1 + R_2) + R_4 = \frac{1}{2} \cdot (R_1 + R_2) + R_4 = \frac{1}{2} \cdot (60 \Omega + 40 \Omega) + 100 \Omega$$

**Exercise E1 Pure Resistor Network Simplification I**  
**(written test, approx. 14 % of a 60-minute written test, SS2023)**

The circuit below should be given as  $U_{\text{AB}} = 60 \text{ V}$ . What is the value for  $I_{\text{AB}}$  the circuit?

Solution

$$I_{\text{AB}} = \frac{U_{\text{AB}}}{R_{\text{eq}}} = \frac{60 \text{ V}}{120 \Omega} = 0.5 \text{ A}$$

The current through the circuit is given as  $I_{\text{AB}} = \frac{U_{\text{AB}}}{R_{\text{eq}}}$ .

This current has to flow in summary through parallel branches. The voltage  $U$  in question in the upper right branch given by  $(4R \parallel 4R) + 2R + 2R$ . Its resistance is just the same as the upper left branch  $6R$ .

Therefore, half of the current flows to the left half to the right side.

The voltage  $U$  is consequently: 
$$U = \frac{I_{\text{arm AB}}}{2 \cdot R_{\text{eq}}} \parallel = \frac{U_{\text{AB}} \cdot 2R}{2 \cdot R_{\text{eq}}} \parallel = \frac{60 \text{ V}}{5}$$

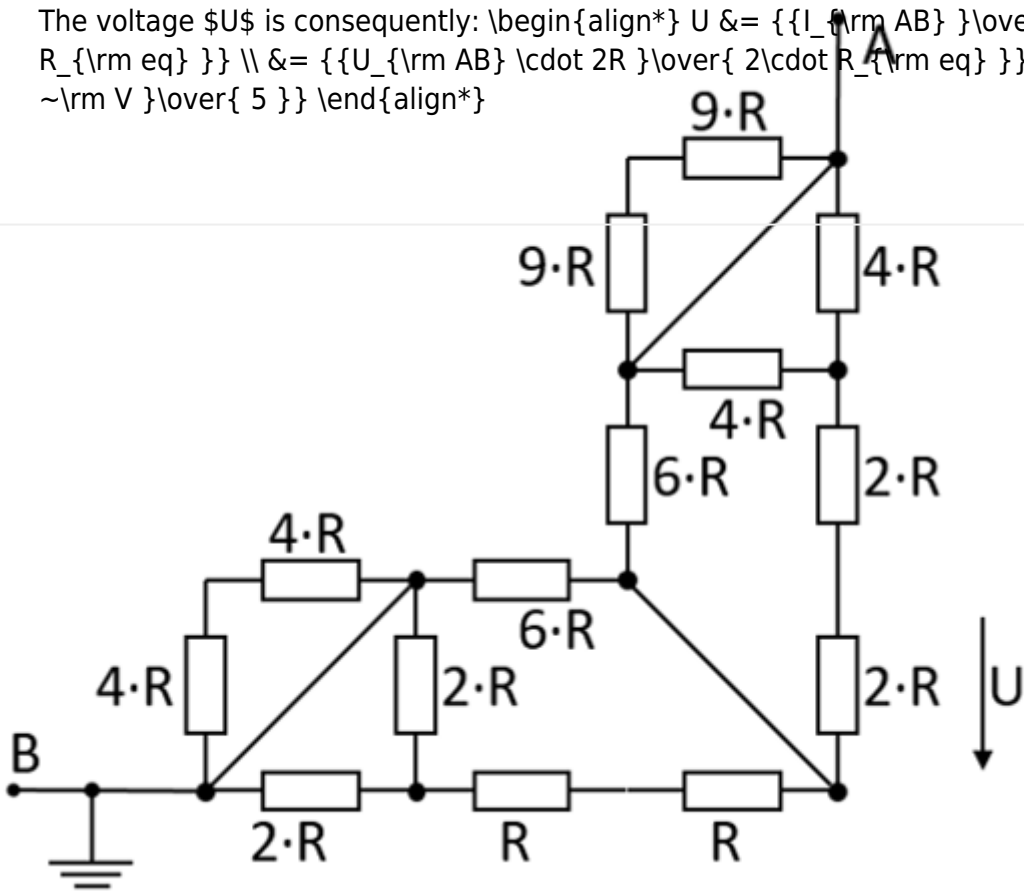

1. What is the equivalent resistance  $R_{\text{eq}}$ ?

Solution

Part of the circuit is shorted. Here the resistors (marked in red) are shorted by the connections marked in blue:

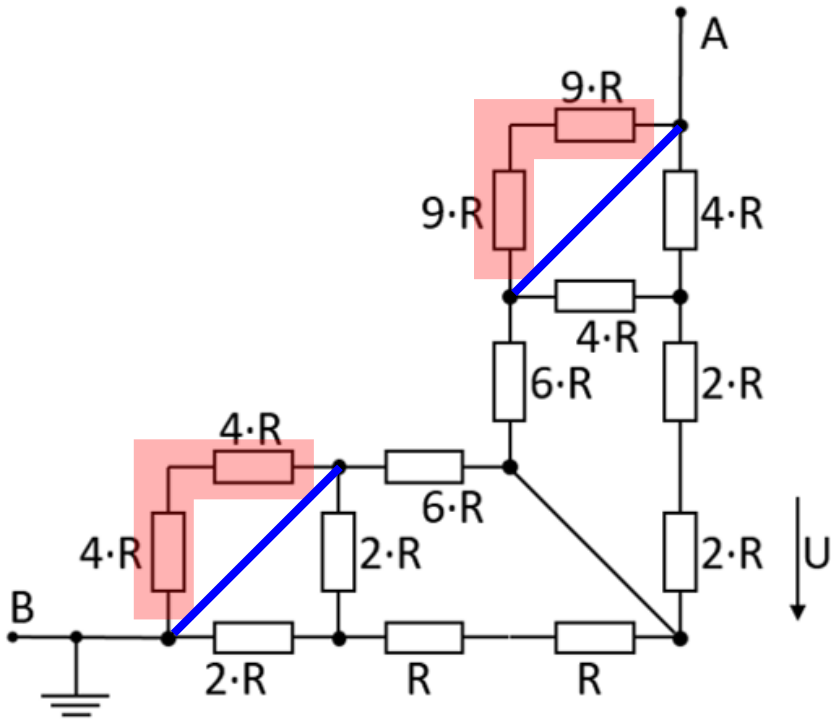

The circuit can then be rearranged for better interpretation:

Therefore,  $R_{\text{eq}}$  is given as: 
$$R_{\text{eq}} = (2R || 2R + R +$$

$$R_1 || 6R + 6R || (2R + 2R + 4R || 4R) || (R + R + R) || 6R + 6R || (2R + 2R + 2R) || \\ \&= 3R || 6R + 6R || 6R || \&= \frac{3R \cdot 6R}{3R + 6R} + 3R \end{align*}$$

**Exercise E2 Equivalent Linear Source**  
**(written test, approx. 10 % of a 60-minute written test, SS2023)**

The circuit below has to be simplified. Use equivalent linear sources for simplification.  
 Calculate the internal resistance  $R_{\text{i}}$  and the source voltage  $U_{\text{s}}$  of an equivalent linear voltage source.

- $R_1 = 5 \text{ } \Omega$
- $U_1 = 10 \text{ V}$
- $R_2 = 5 \text{ } \Omega$
- $I_3 = 0.5 \text{ A}$
- $R_4 = 10 \text{ } \Omega$
- $U_5 = 4 \text{ V}$

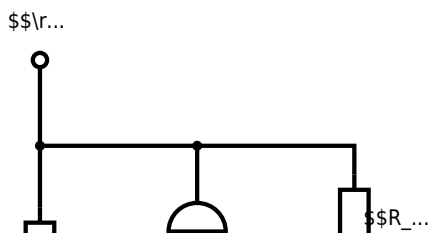

### Solution

The principle idea here is to find parts of the circuit which are already a linear (voltage or current) source. Then this can be transformed into the equivalent other source, as shown in the next picture.

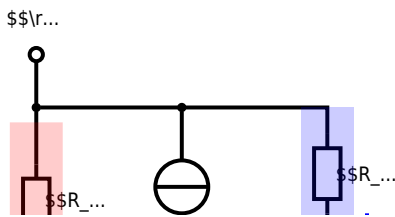

In order to get the currents one has to calculate it by  $I_x = \frac{U_x}{R_x}$

$$\begin{aligned} I_0 &= \frac{U_0}{R_1} = \frac{10 \text{ V}}{5 \text{ } \Omega} = 2 \text{ A} \\ I_5 &= \frac{U_5}{R_4} = \frac{4 \text{ V}}{10 \text{ } \Omega} = 0.4 \text{ A} \end{aligned}$$

$I_3$  and  $I_0$  can be combined to  $I_{03} = I_0 - I_3$  facing upwards:

$$I_{03} = 1.5 \text{ A}$$

Then, the linear current source  $I_{03}$  with  $R_1$  gets transformed into a linear voltage source with  $U_{03} = R_1 \cdot I_{03}$  facing down.

$$U_{03} = 7.5 \text{ V}$$

Then, the resistors  $R_1$  and  $R_2$  can be combined to  $R_{12} = R_1 + R_2$ .

After this, the next step is to make a linear current source out of  $U_{03}$  and  $R_{12}$ . The current will be  $I_{0123} = \frac{U_{03}}{R_{12}}$ , facing up again.

$$I_{0123} = 0.6 \text{ A}$$

The second-last step is the sum up of the current sources  $I_{0123}$  and  $I_5$  as  $I_{01235} = I_{0123} - I_5$  and the resistors as  $R_{124} = R_{12} || R_4$ .

$$I_{01235} = 0.2 \text{ A} \quad R_{124} = 5.55 \text{ } \Omega$$

The final step is the back-transformation to a linear voltage source, with  $U_{\text{AB}} = R_{124} \cdot I_{01235}$ .

The simplest and fastest (= for exams) is to work with interim results in the calculation.

Here, there there is also a full final formula given:

$$U_{\text{AB}} = U_{\text{AB}} = I_{01235} \cdot R_{124} = (I_{0123} - I_5) \cdot (R_{12} \parallel R_4) = \left( \frac{U_3}{R_{12}} - I_5 \right) \cdot (R_{12} \parallel R_4) = \left( \frac{R_1 \cdot I_3}{R_1 + R_2} - I_5 \right) \cdot (R_{12} \parallel R_4) = \frac{R_1 \cdot \left( \frac{U_0}{R_1} - I_3 \right)}{R_1 + R_2} - I_5 \cdot (R_{12} \parallel R_4)$$

**Exercise E1 (Dis)Charging Capacities (written test, approx. 14 % of a 60-minute written test, SS2023)**

The circuit below consists of a current source  $I_0 = 0.2 \text{ mA}$ , a voltage source  $U_0 = 10 \text{ V}$ , a capacitor  $C = 200 \text{ nF}$ , and resistors  $R_1 = 8 \text{ k}\Omega$ ,  $R_2 = 17 \text{ k}\Omega$ ,  $R_3 = 10 \text{ k}\Omega$ , and  $R_4 = 50 \text{ k}\Omega$ . The switch  $S_1$  switches to the situation shown in the drawing. What is the new time constant?

- $C = 200 \text{ nF}$

Solution:  $R = 8.0 \text{ k}\Omega$   
 Solution:  $\tau = 8.0 \text{ k}\Omega \cdot 200 \text{ nF} = 1.6 \text{ ms}$   
 Solution:  $U_C = 25 \text{ V}$   

$$U_C = U_0 \cdot \left( 1 - e^{-\frac{t}{\tau}} \right)$$

The current of the source flows through the circuit consisting of  $C$  in parallel with  $R_1$  and  $R_2$ . Without the parallel resistors, the current source would charge the capacitor "to infinity" ( $C \rightarrow \infty$ ). This is here limited by the parallel resistors  $R_1$  and  $R_2$ . Then, the source  $U_0$  drives the current through the series circuit given by  $I_0$ ,  $C$ ,  $R_1$  and  $R_2$ .

The maximum voltage on the branch with the resistors  $(R_1 \parallel R_2) \cdot C = (8 \text{ k}\Omega + 17 \text{ k}\Omega) \cdot 0.2 \text{ mA} = 25 \text{ V}$   

$$U_C = U_0 \cdot \frac{R_1 \parallel R_2}{R_1 \parallel R_2 + C} = \frac{U_0 \cdot (R_1 \parallel R_2)}{R_1 \parallel R_2 + C}$$

This is also the maximum voltage on the capacitor, since it is in parallel with the resistors.

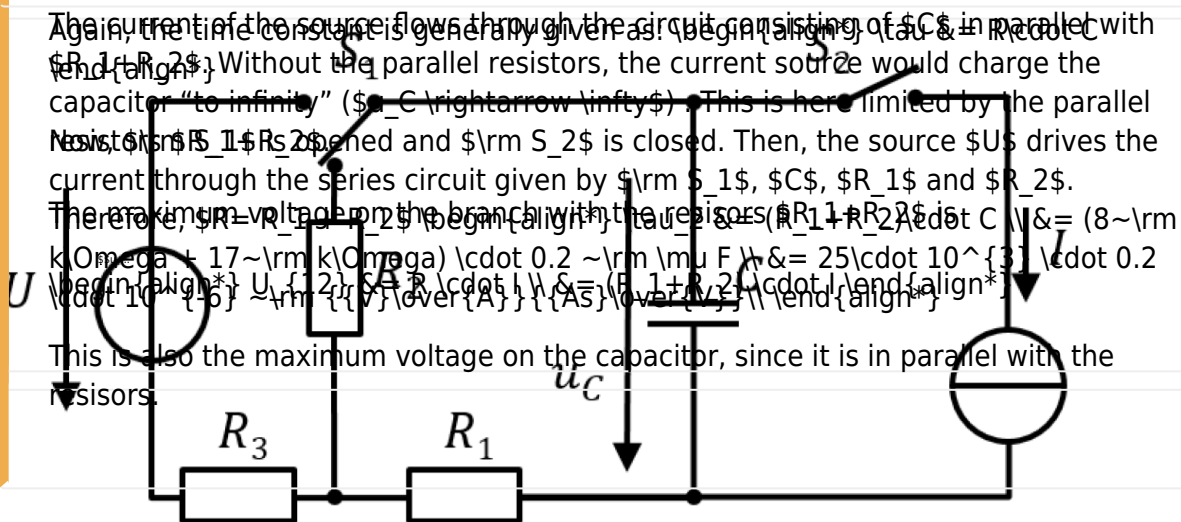

Before  $t_0$  all switches are switched as shown and the capacitor is fully discharged. At  $t_0 = 0 \text{ s}$  the switch  $S_1$  shall switch to the voltage source.

1. Calculate the time constant for charging the capacitor.

### Solution

The time constant is generally given as:  $\tau = R \cdot C$

Once  $S_1$  is closed and  $S_2$  is open at  $t_0$ , the source  $U$  drives the current through the series circuit given by  $S_1$ ,  $C$ ,  $R_1$  and  $R_3$ .

Therefore,  $R = R_1 + R_3$   

$$\tau_1 = (R_1 + R_3) \cdot C = (8 \text{ k}\Omega + 7 \text{ k}\Omega) \cdot 0.2 \text{ }\mu\text{F} = 15 \cdot 10^3 \cdot 0.2 \cdot 10^{-6} \text{ s} = 3 \text{ ms}$$

...

### Solution

Both courses of the voltage for charging and discharging are described with an exponential function. However, the curve for charging increases first steep and flattens out for longer time scales ( $1 - e^{-x}$ ).

### Exercise E3 Impedances at Frequencies (written test, approx. 14 % of a 60-minute written test, SS2023)

At a high frequency with  $C_2 \rightarrow 50 \text{ pF}$  (following the procedure in the previous exercise) the value of the

Repeat the calculation with  $\mu = 0.5$  and  $L = 15.9 \mu\text{H}$ .

Solution

```

\begin{align*} f_0 &= 3000000.5 \text{ Hz} \\ \omega &= 2\pi f_0 \\ X_{L_1} &= \omega L_1 \\ X_{C_2} &= \frac{1}{\omega C_2} \\ X_{L_2} &= \omega L_2 \\ X_{C_1} &= \frac{1}{\omega C_1} \\ Z_{in} &= X_{L_1} + X_{C_2} + X_{L_2} + X_{C_1} \\ I_{eff} &= \frac{V_s}{|Z_{in}|} \\ P_{avg} &= I_{eff}^2 R_{load} \\ \eta &= \frac{P_{avg}}{P_{source}} \end{align*}

```

Exercise E1 Efficiency

(written test, approx. 14 % of a 60-minute written test, SS2023)

2. (100 points) A battery with an open-circuit voltage of 3.5 V and an internal resistance of 0.5  $\Omega$  is connected to a load resistor. The battery shall provide energy for a device with an load resistance of  $R_L = 2 + j\omega$   $\Omega$ . The following values are given:

Result: The lowest possible efficiency is 0.05.

```

\begin{align*} \eta &= \frac{P_{load}}{P_{source}} \\ \eta &= \frac{I^2 R_L}{I^2 (R_L + R_{int})} \\ \eta &= \frac{R_L}{R_L + R_{int}} \\ \eta &= \frac{2}{2 + 0.5} \\ \eta &= 0.8 \end{align*}

```

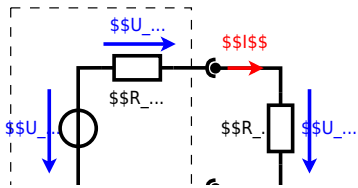

From:  
<https://wiki.mexle.org/> - MEXLE Wiki

Permanent link:  
[https://wiki.mexle.org/electrical\\_engineering\\_and\\_electronics\\_1/ss2023\\_exam?rev=1768171400](https://wiki.mexle.org/electrical_engineering_and_electronics_1/ss2023_exam?rev=1768171400)

Last update: 2026/01/11 23:43

