

# Block 08 - Oscillating Circuits

## Student Group

First Name	Surname	Matrikel Nr.

## Table of Contents

- Block 08 - Oscillating Circuits** ..... 3
- Learning objectives* ..... 3
- Preparation at Home* ..... 3
- 90-minute plan* ..... 3
- Conceptual overview* ..... 3
- Core content* ..... 3
- From Two-Terminal Network to Four-Terminal Network* ..... 3
  - Reminder: ..... 5
- RL Series Circuit** ..... 5
  - RL High Pass ..... 6
  - Reminder: ..... 8
  - RL Low Pass ..... 9
- RC Series Circuit** ..... 9
  - RC High Pass ..... 9
  - RC Low Pass ..... 10
  - RLC - Series Resonant Circuit ..... 10
    - Series Resonant Circuit in Time Domain (Voltage on Inductor) ..... 13
    - Series Resonant Circuit in Frequency Domain (Voltage on Inductor) ..... 13
    - Series Resonant Circuit in Frequency Domain (Voltage on Capacitor) ..... 13
    - Series Resonant Circuit in Frequency Domain (Voltage on Resistor) ..... 13
    - Parallel Resonant Circuit in Frequency Domain (Voltage on Resistor) ..... 13
- Applications of Inductors** ..... 14
- Examples** ..... 14
  - Decoupling Capacitor on the Microcontroller ..... 14
  - Crystal as Resonant Circuit ..... 14
- Exercises** ..... 14
  - Exercise 6.3.1 Series Resonant Circuit I ..... 14
  - Exercise 6.3.2 Series Resonant Circuit II ..... 14
- Common pitfalls** ..... 16

**Exercises** ..... 16  
    Worked examples ..... 16  
**Embedded resources** ..... 16

# Block 08 - Oscillating Circuits

## Learning objectives

After this 90-minute block, you

1. Know the formula of the instantaneous power of the resistor, inductor, and capacitor and be able to determine its values.

## Preparation at Home

Well, again

- read through the present chapter and write down anything you did not understand.
- Also here, there are some clips for more clarification under 'Embedded resources' (check the text above/below, sometimes only part of the clip is interesting).

For checking your understanding please do the following exercises:

- ...

## 90-minute plan

1. Warm-up (x min):
  1. ....
2. Core concepts & derivations (x min):
  1. ...
3. Practice (x min): ...
4. Wrap-up (x min): Summary box; common pitfalls checklist.

## Conceptual overview

1. ...

## Core content

### From Two-Terminal Network to Four-Terminal Network

Fig. 1: Two-Terminal Network to Four-Terminal Network



Until now, components such as resistors, capacitors, and inductors have been understood as two-terminal. This is also obvious since there are only two connections. In the following however circuits are considered, which behave similarly to a voltage divider: On one side a voltage  $U_{\text{I}}$  is applied, and on the other side  $U_{\text{O}}$  is formed with it. This results in 4 terminals. The circuit can and will be considered as a four-terminal network in the following. However, the input and output values will be complex.

For a four-terminal network, the relation of “what goes out” (e.g.  $U_{\text{O}}$  or  $U_2$ ) to “what goes in” (e.g. voltage  $U_{\text{I}}$  or  $U_1$ ) is important. Thus, the output and input variables ( $U_{\text{O}}$ ) and ( $U_{\text{I}}$ ) give the quotient:

$$\underline{A} = \frac{\underline{U}_{\text{O}}}{\underline{U}_{\text{I}}} \quad \text{with};$$

$$\underline{U}_{\text{O}} = U_{\text{O}} \cdot e^{j \varphi_{\text{O}}} \quad \text{and};$$

$$\underline{U}_{\text{I}} = U_{\text{I}} \cdot e^{j \varphi_{\text{I}}} \quad \underline{A} = \frac{U_{\text{O}} \cdot e^{j \varphi_{\text{O}}}}{U_{\text{I}} \cdot e^{j \varphi_{\text{I}}}} = \frac{U_{\text{O}}}{U_{\text{I}}} \cdot e^{j(\varphi_{\text{O}} - \varphi_{\text{I}})}$$

$$\boxed{\underline{A}} = \frac{\underline{U}_{\text{O}}}{\underline{U}_{\text{I}}} = \frac{U_{\text{O}}}{U_{\text{I}}} \cdot e^{j \Delta \varphi}$$

**Reminder:**

- The complex-valued quotient  $\frac{\underline{U}_{\text{O}}}{\underline{U}_{\text{I}}}$  is called the **transfer function**.
- The frequency-dependent magnitude of the quotient  $A(\omega) = \frac{U_{\text{O}}}{U_{\text{I}}}$  is called **amplitude response** and the angular difference  $\Delta\varphi_u(\omega)$  is called **phase response**.

The frequency behavior of the amplitude response and the frequency response is not only important in electrical engineering and electronics but will also play a central role in control engineering.

## RL Series Circuit

Fig. 2: RL-series



First, a series connection of a resistor  $R$  and an inductor  $L$  shall be considered (see figure 2). This structure is also called RL-element.

Here,  $\underline{U}_{\text{I}} = \underline{X}_{\text{I}} \cdot \underline{I}$  with  $\underline{X}_{\text{I}} = R + j\omega L$  and corresponding for  $\underline{U}_{\text{O}}$ : 
$$\underline{A} = \frac{\underline{U}_{\text{O}}}{\underline{U}_{\text{I}}} = \frac{\omega L}{\sqrt{R^2 + (\omega L)^2}} \cdot e^{j\left(\frac{\pi}{2} - \arctan \frac{\omega L}{R}\right)}$$

This results in the following for

- the amplitude response:  $A = \frac{\omega L}{\sqrt{R^2 + (\omega L)^2}}$  and
- the phase response:  $\Delta\varphi_u = \arctan \frac{R}{\omega L} = \frac{\pi}{2} - \arctan \frac{\omega L}{R}$

The main focus should first be on the amplitude response. Its frequency response can be derived from the equation in various ways.

1. Extreme frequency consideration of this RL circuit (in the equation and the system)
2. Plotting amplitude and frequency response
3. Determination of prominent frequencies

These three points are now to be gone through.

## RL High Pass

For the first step, we investigate the limit consideration: We look at what happens when the frequency  $\omega$  runs to the definition range limits, i.e.  $\omega \rightarrow 0$  and  $\omega \rightarrow \infty$ :

- For  $\omega \rightarrow 0$ ,  $A = \frac{\omega L}{\sqrt{R^2 + (\omega L)^2}} \rightarrow 0$  as the numerator approaches zero and the denominator remains greater than zero.
- For  $\omega \rightarrow \infty$ ,  $A \rightarrow 1$ , because in the root in the denominator  $(\omega L)^2$  becomes larger and larger in the ratio  $R^2$  to  $(\omega L)^2$ . So the root tends to  $\omega L$  and thus to the numerator.

It can thus be seen that:

- at small frequencies there is no voltage  $U_2$  at the output.
- at high frequencies  $A = \frac{U_{\text{O}}}{U_{\text{I}}} \rightarrow 1$ , so the voltage at the output is equal to the voltage at the input.

Result:

The RL element shown here therefore only allows large frequencies to pass (= pass through) and small ones are filtered out.

The circuit corresponds to a **high pass**.

This can also be derived from understanding the components:

- At small frequencies, the current in the coil and thus the magnetic field changes only slowly. So only a negligibly small reverse voltage is induced. The coil acts like a short circuit at low frequencies.
- At higher frequencies, the current generated by  $U_1$  through the coil changes faster, the induced voltage  $U_{\text{i}} = - \frac{dI}{dt} L$  becomes large. As a result, the coil inhibits the current flow and a voltage drops across the coil.
- If the frequency becomes very high, only a negligible current flows through the coil - and hence through the resistor. The voltage drop at  $R$  thus approaches zero and the output voltage  $U_{\text{O}}$  tends towards  $U_{\text{I}}$ .

The transfer function can also be decomposed into amplitude response and frequency response. Often these plots are not given in with linear axis but:

- the amplitude response with a double logarithmic coordinate system and
- the phase response single logarithmic coordinate system.

By this, the course from low to high frequencies is easier to see. The following simulation in [figure 3](#) shows the amplitude response and frequency response in the lower left corner.

Fig. 3: RL high pass filter

For further consideration, the equation of the transfer function  $\underline{A} = \frac{\underline{U}_{\text{O}}}{\underline{U}_{\text{I}}}$  is to be rewritten so that it becomes independent of component values  $R$  and  $L$ .

This allows for a generalized representation. This representation is called **normalization**:

$$\begin{aligned} \underline{A} &= \frac{\underline{U}_O}{\underline{U}_I} = \frac{\omega L}{\sqrt{R^2 + (\omega L)^2}} \cdot e^{j\left(\frac{\pi}{2} - \arctan\left(\frac{\omega L}{R}\right)\right)} \\ \underline{A}_{\text{norm}} &= \frac{\omega L / R}{\sqrt{1 + (\omega L / R)^2}} \cdot e^{j\left(\frac{\pi}{2} - \arctan\left(\frac{\omega L}{R}\right)\right)} \\ &= \frac{x}{\sqrt{1 + x^2}} \cdot e^{j\left(\frac{\pi}{2} - \arctan x\right)} \end{aligned}$$

This equation behaves quite the same as the one considered so far.

figure 4 shows the two plots. On the x-axis,  $x = \omega L / R$  has been plotted as the normalization variable. This represents a weighted frequency.

Fig. 4: Amplitude and phase response of the RL high-pass filter

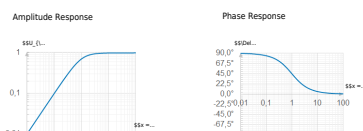

Here, too, the behavior determined in the limit value observation can be seen:

- at small frequencies  $\omega$  (corresponds to small  $x$ ), the amplitude response tends toward zero.
- At high frequencies, the ratio  $U_O / U_I = 1$  is established.

Interesting in the phase response is the point  $x = 1$ .

- Further to the left of this point (i.e. at smaller frequencies) a tenfold increase of the frequency  $\omega$  produces a tenfold increase of  $U_O / U_I$ .
- Further to the right of this point (i.e. at higher frequencies)  $U_O / U_I = 1$  remains.

So this point marks a limit. Far to the left, the ohmic resistance is significantly greater than the amount of impedance of the coil:  $R \gg \omega L$ . far to the right is just the opposite.

The point  $x=1$  just marks the cut-off frequency.  
It holds

```

\begin{align*}
\phantom{\HUGE{}} \left\{ \begin{array}{l}
x \ll 1 & \& \\
\widehat{=} & \& \omega \\
L \ll R \ , \ : & \quad \& \\
\frac{x}{\sqrt{1+x^2}} \cdot \varphi & = \\
\frac{U_O}{U_I} & = x \ , \\
\arctan x \ \text{right)} & = \widehat{=} \ , \ 90^\circ \ \& \\
x \gg 1 & \& \\
\widehat{=} & \& \omega \\
L \gg R \ , \ : & \quad \& \\
\frac{U_O}{U_I} & = 1 \ \& \\
\varphi & = 0 \ ; \\
\widehat{=} & \ , \ 0^\circ \ \& \\
= 1 \ \& \widehat{=} & \\
\omega L = R \ , \ : & \quad \& \\
\frac{U_O}{U_I} & = \frac{1}{\sqrt{2}} \ \& \\
\varphi & = \frac{\pi}{4} \ \& \\
\widehat{=} & \ , \ 45^\circ \\
\end{array} \right.
\end{align*}

```

**Reminder:**

- The **cut-off frequency**  $f_c$  for high-pass and low-pass filters is the frequency at which the ohmic resistance just equals the value of the impedance.
- The cut-off frequency separates a range in which the filter allows signals through from one in which they are suppressed (=blocked).
- At the cut-off frequency, the phase  $\varphi = 45^\circ$  and the amplitude  $A = \frac{1}{\sqrt{2}}$ .
- In German the cut-off Frequency is called *Grenzfrequenz*  $f_{Gr}$

These statements apply to single-stage passive filters, i.e. one RL or one RC element. Multistage filters are considered in circuit engineering.

The cut-off frequency, in this case, is given by:

$$R = \omega L \quad \omega_c = \frac{R}{L} \quad f_c = \frac{R}{2\pi L} \quad \rightarrow \quad \boxed{f_c = \frac{R}{2\pi L}}$$

## RL Low Pass

Fig. 5: Circuit, pointer diagram, and amplitude and phase response of RL low-pass filter

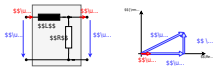

So far, only one variant of the RL element has been considered, namely the one where the output voltage  $\underline{U}_{\text{O}}$  is tapped at the inductance.

Here we will briefly discuss what happens when the two components are swapped.

In this case, the normalized transfer function is given by:

$$\underline{A}_{\text{norm}} = \frac{1}{\sqrt{1 + (\omega L / R)^2}} \cdot e^{-j \arctan \frac{\omega L}{R}}$$

The cut-off frequency is again given by  $f_c = \frac{R}{2 \pi \cdot L}$ .

Fig. 6: RL low pass filter

## RC Series Circuit

### RC High Pass

Fig. 7: Circuit, pointer diagram, and amplitude and phase response of the RC high-pass filter

Now a voltage divider is to be constructed by a resistor  $R$  and a capacity  $C$ . Quite similar to the previous chapters, the transfer function can also be determined here.

Here results as normalized transfer function:

$$\underline{A}_{\text{norm}} = \frac{\omega RC}{\sqrt{1 + (\omega RC)^2}} \cdot e^{j \arctan (\omega RC)}$$

In this case, the normalization variable  $x = \omega RC$ . Again, the cut-off frequency is determined

by equating  $R$  and the magnitude of the impedance of the capacitance:

$$\begin{aligned} R &= \frac{1}{\omega C} \\ \omega C &= \frac{1}{RC} \\ \omega &= \frac{1}{RC} \quad \rightarrow \quad \boxed{f_c = \frac{1}{2\pi RC}} \end{aligned}$$

Fig. 8: RC high pass filter

## RC Low Pass

Fig. 9: Circuit, pointer diagram, and amplitude and phase response of RC low-pass filter

Again, the voltage at the impedance is to be used as the output voltage. This results in a low-pass filter.

Here results as normalized transfer function:

$$\underline{A}_{\text{norm}} = \frac{1}{\sqrt{1 + (\omega RC)^2}} \cdot e^{-j \arctan(\omega RC)}$$

Also, the cut-off frequency is given by  $f_c = \frac{1}{2\pi RC}$

Fig. 10: RC low pass filter

## RLC - Series Resonant Circuit

As seen before, the circuits with complex impedances can be interpreted as four-terminal networks. There, we will again look at “output versus input”, i.e:  $A_V = \frac{U_O}{U_I} \rightarrow \underline{A}_V = \frac{\underline{U}_O}{\underline{U}_I}$ .

In this chapter, we look at a combination where all three components resistor  $R$ , capacitor  $C$ , and inductance  $L$  are used.

Fig. 1: circuit of the series resonant circuit

If a resistor  $R$ , a capacitor  $C$ , and an inductance  $L$  are connected in series, the result is a **series resonant circuit**. In this case, it is not clearly defined, what the output voltage is. Consequently, it must be considered how the voltages behave across all the individual components in the following. The total voltage (= input voltage  $U_I$ ) results to:

$$\underline{U}_I = \underline{U}_R + \underline{U}_L + \underline{U}_C$$

Since the current in the circuit must be constant, the total impedance can be determined here in a simple way:

$$\underline{U}_I = R \cdot \underline{I} + j \omega L \cdot \underline{I} + \frac{1}{j \omega C} \cdot \underline{I} \quad \underline{U}_I = \left( R + j \omega L - \frac{j}{\omega C} \right) \cdot \underline{I} \quad \underline{Z} = R + j \omega L - \frac{j}{\omega C}$$

By this, the magnitude of the (input) voltage  $U_I$ , the (input or total) impedance  $Z$ , and the phase result to:

$$U_I = \sqrt{U_R^2 + (U_Z)^2} = \sqrt{U_R^2 + (U_L - U_C)^2}$$

$$Z = \sqrt{R^2 + X^2} = \sqrt{R^2 + (\omega L - \frac{1}{\omega C})^2}$$

$$\varphi_u = \varphi_Z = \arctan \frac{\omega L - \frac{1}{\omega C}}{R}$$

There are now 3 different situations to distinguish:

- If  $U_L > U_C$  the whole setup behaves like an ohmic-inductive load. This is the case at high frequencies.
- If  $U_L = U_C$ , the total input voltage  $U$  is applied to the resistor. In this case, the total resistance  $Z$  is minimal and only ohmic. Thus, the current  $I$  is then maximal. If the current is maximum, then the responses of the capacitance and inductance - their voltages - are also maximum. This situation is the **resonance case**.
- If  $U_L < U_C$  then the whole setup behaves like a resistive-capacitive load. This is the case at low frequencies.

Again, there seems to be a singular frequency, namely when  $U_L = U_C$  or  $Z_L = Z_C$  holds:

$$\frac{1}{\omega_0 C} = \omega_0 L \quad \omega_0 = \frac{1}{\sqrt{LC}} \quad 2\pi f_0 = \frac{1}{\sqrt{LC}} \quad \rightarrow \boxed{f_0 = \frac{1}{2\pi \sqrt{LC}}}$$

The frequency  $f_0$  is called **resonance frequency**.

	$f \rightarrow 0$	$f = f_0$	$f \rightarrow \infty$
voltage $U_R$ at the resistor	$U$	since the impedances just cancel out	$U$
voltage $U_L$ at the inductor	becomes very small	$\omega_0 L \cdot I = \omega_0 L \cdot \frac{U}{R} = \frac{1}{R} \sqrt{\frac{L}{C}} \cdot U$	becomes very large
voltage $U_C$ at the capacitor	becomes very large	$\frac{1}{\omega_0 C} \cdot I = \frac{1}{\omega_0 C} \cdot \frac{U}{R} = \frac{1}{R} \sqrt{\frac{L}{C}} \cdot U$	becomes very small

The calculation in the table shows that in the resonance case, the voltage across the capacitor or inductor deviates from the input voltage by a factor  $\frac{1}{R} \sqrt{\frac{L}{C}}$ . This quantity is called **quality or Q-factor**  $Q_S$ :

$$\boxed{Q_S = \frac{U_C}{U} \Big|_{\omega = \omega_0} = \frac{U_L}{U} \Big|_{\omega = \omega_0} = \frac{1}{R} \sqrt{\frac{L}{C}}}$$

The quality can be greater than, less than, or equal to 1. The quality  $Q_S$  does not have a unit and should not be confused with the charge  $Q$ .

- If the quality is very high, the overshoot of the voltages at the impedances becomes very large in the resonance case. This is useful and necessary in various applications, e.g. in an RLC

element as an antenna.

- If the  $Q$  is very small, overshoot is no longer seen. Depending on the impedance at which the output voltage is measured, a high-pass or low-pass is formed similar to the  $RC$  or  $RL$  element. However, this has a steeper slope in the blocking range. This means that the filter effect is better.

The reciprocal of the  $Q$  is called **attenuation**  $d_{\text{S}}$ . This is specified when using the circuit as a non-overshooting filter.

$$\boxed{d_{\text{S}} = \frac{1}{Q_{\text{S}}} = R \sqrt{\frac{C}{L}}}$$

Fig. 2: Amplitude and Phase Response of a Series Resonant Circuit

440 21 Amplitude Response

### Series Resonant Circuit in Time Domain (Voltage on Inductor)

### Series Resonant Circuit in Frequency Domain (Voltage on Inductor)

### Series Resonant Circuit in Frequency Domain (Voltage on Capacitor)

### Series Resonant Circuit in Frequency Domain (Voltage on Resistor)

### Parallel Resonant Circuit in Frequency Domain (Voltage on Resistor)

## Applications of Inductors

- ferrite bead
- Decoupling
- Filter
- unwanted coupling and circuit design

## Examples

### Decoupling Capacitor on the Microcontroller

[Simulation in Falstad](#). Note: The simulation gives a highly simplified picture. The response of the microcontroller is shown reduced to a triangular signal, since the slope of the voltages cannot be represented. A real simulation requires a powerful SPICE program in which the [conduction theory](#) can be represented.

Further details can be found [here \(practice\)](#), [here \(layout\)](#), also [Layout](#) or [Layout](#).

### Crystal as Resonant Circuit

[more background](#)

Simulation in Time Domain

Simulation in Frequency Domain

[setup for the design](#)

## Exercises

### Exercise 6.3.1 Series Resonant Circuit I

A  $R$ - $L$ - $C$  series circuit uses a capacity of  $C=100 \text{ }\mu\text{F}$ . A voltage source with  $U_I$  feeds the circuit at  $f_1 = 50 \text{ Hz}$ .

1. Which values does  $R$  and  $L$  need to have, when the resonance voltage  $\underline{U}_L$  and  $\underline{U}_C$  at  $f_1$  shall show the double value of the input voltage  $U_I$ ?
2. The components of question 1. shall now be used. What would be the value of  $\frac{\underline{U}_C}{\underline{U}_I}$  for  $f_2 = 60 \text{ Hz}$ ?

### Exercise 6.3.2 Series Resonant Circuit II

A given  $R$ - $L$ - $C$  series circuit is fed with a frequency,  $20\%$  larger than the

Resonance frequency keeping the amplitude of the input voltage constant. In this situation, the circuit shows a current 30% lower than the maximum current value.

Calculate the Quality  $Q = \frac{1}{R} \sqrt{\frac{L}{C}}$ .

$$\begin{aligned} \text{Solution} \quad Q &= \frac{\sqrt{\frac{1}{0.7^2} - 1}}{1.2 - \frac{1}{1.2}} \\ Q &= 2.782... \rightarrow Q = 2.78 \end{aligned}$$

The solution looks hard at first since no insights for the values of  $R$ ,  $C$ , and  $L$  are given.

However, it is possible and there are multiple ways to solve it.

### What we know

But first, add some more info, which is always true from resonant circuits at the resonant frequency:

1.  $\omega_0 = \frac{1}{\sqrt{LC}}$
2.  $X_{C0} = -X_{L0}$
3.  $Z = \sqrt{R^2 + (X_L + X_C)^2}$ , based on the sum of the impedances  
 $\underline{Z}_{\text{req}} = \underline{X}_R + \underline{X}_C + \underline{X}_L$  and the Pythagorean theorem

From the task, the following is also known.

1. Using "a frequency, 20% larger than the resonance frequency":
  1.  $f = 1.2 \cdot f_0$  and
  2.  $\omega = 1.2 \cdot \omega_0$
2. The circuit shows a current 30% lower than the maximum current value:
  1. The maximum current for the series resonant circuit is given for the minimum impedance  $Z$ .  
The minimum impedance  $Z$  is given at resonance frequency, and is  $Z_{\text{min}} = R$
  2. Therefore:  $Z = \frac{1}{0.7} \cdot R$

### Solution 2: The fast path

We start with  $Z = \sqrt{R^2 + (X_L + X_C)^2}$  for the cases: (1) at the resonant frequency  $f_0$  and (2) at the given frequency  $f = 1.2 \cdot f_0$

$$\begin{aligned} \text{(1): } Z_0 &= R \quad \text{(2): } Z = \sqrt{R^2 + (X_L + X_C)^2} \end{aligned}$$

In formula (2) the impedance  $X_L$  and  $X_C$  are:

- $X_L = \omega \cdot L$  and therefore also  $X_L = 1.2 \cdot \omega_0 \cdot L = 1.2 \cdot X_{L0}$

- $X_C = -\frac{1}{\omega \cdot C}$  and therefore also  $X_C = -\frac{1}{1.2 \cdot \omega \cdot C} = -\frac{1}{1.2} \cdot X_{C0}$

With  $X_{C0} = X_{L0}$  we get for (1):

$$\begin{aligned} Z &= \sqrt{R^2 + \left(1.2 \cdot X_{L0} - \frac{1}{1.2} X_{L0}\right)^2} \\ &= \sqrt{R^2 + X_{L0}^2 \cdot \left(1.2 - \frac{1}{1.2}\right)^2} \end{aligned}$$

Since we know that  $Z = \frac{1}{0.7} \cdot R$  and  $Z_0 = R$ , we can start by dividing (2) by (1):

$$\begin{aligned} \frac{(2)}{(1)} : \quad \frac{Z}{Z_0} &= \frac{\sqrt{R^2 + (X_L + X_C)^2}}{R} \quad \& \quad \text{\textit{put in the info from before}} \quad \& \quad \frac{1}{0.7} = \frac{\sqrt{R^2 + X_{L0}^2 \cdot \left(1.2 - \frac{1}{1.2}\right)^2}}{R} \quad \& \quad \dots \\ & \quad \& \quad \frac{1}{0.7^2} = \frac{R^2 + X_{L0}^2 \cdot \left(1.2 - \frac{1}{1.2}\right)^2}{R^2} \quad \& \quad \cdot R^2 \quad \& \quad \frac{1}{0.7^2} \cdot R^2 \\ & \quad \& \quad R^2 = R^2 + X_{L0}^2 \cdot \left(1.2 - \frac{1}{1.2}\right)^2 \quad \& \quad - R^2 \quad \& \quad \left(\frac{1}{0.7^2} - 1\right) \cdot R^2 = X_{L0}^2 \cdot \left(1.2 - \frac{1}{1.2}\right)^2 \quad \& \quad : R^2 \quad | : \left(1.2 - \frac{1}{1.2}\right)^2 \\ & \quad \& \quad \frac{X_{L0}^2}{R^2} = \frac{\left(\frac{1}{0.7^2} - 1\right)}{\left(1.2 - \frac{1}{1.2}\right)^2} \quad \& \quad \sqrt{\dots} \quad \& \quad \frac{X_{L0}}{R} = \sqrt{\frac{\left(\frac{1}{0.7^2} - 1\right)}{1.2 - \frac{1}{1.2}}} \quad \& \quad \text{\textit{with } } X_{L0} = \omega_0 \cdot L = \frac{1}{\sqrt{LC}} \cdot L = \sqrt{\frac{L}{C}} \quad \& \quad \frac{1}{R} \cdot \sqrt{\frac{L}{C}} = \sqrt{\frac{1}{0.7^2} - 1} \quad \& \quad \frac{1}{1.2 - \frac{1}{1.2}} \end{aligned}$$

## Common pitfalls

- ...

## Exercises

## Worked examples

## Embedded resources

Explanation (video): ...

From:

<https://wiki.mexle.org/> - **MEXLE Wiki**

Permanent link:

[https://wiki.mexle.org/electrical\\_engineering\\_and\\_electronics\\_2/block08](https://wiki.mexle.org/electrical_engineering_and_electronics_2/block08)

Last update: **2026/04/21 04:01**



