

Duty Cycle Adjustment

Student Group

First Name	Surname	Matrikel Nr.

Table of Contents

Duty Cycle Adjustment 2
Background Information 2
Experimental Tasks 2

Duty Cycle Adjustment

Background Information

After combining the Schmitt trigger and the integrator, the circuit generates a periodic signal with a fixed duty cycle. For many PWM applications, however, it is necessary to adjust the duty cycle in order to control the average power delivered to the load.

In the case of an LED, changing the duty cycle directly affects the perceived brightness. Therefore, the oscillator circuit is modified so that the duty cycle can be varied to control the brightness of the LED.

Experimental Tasks

To analyze how to adjust the duty cycle of the PWM-signal, the following circuit is used:

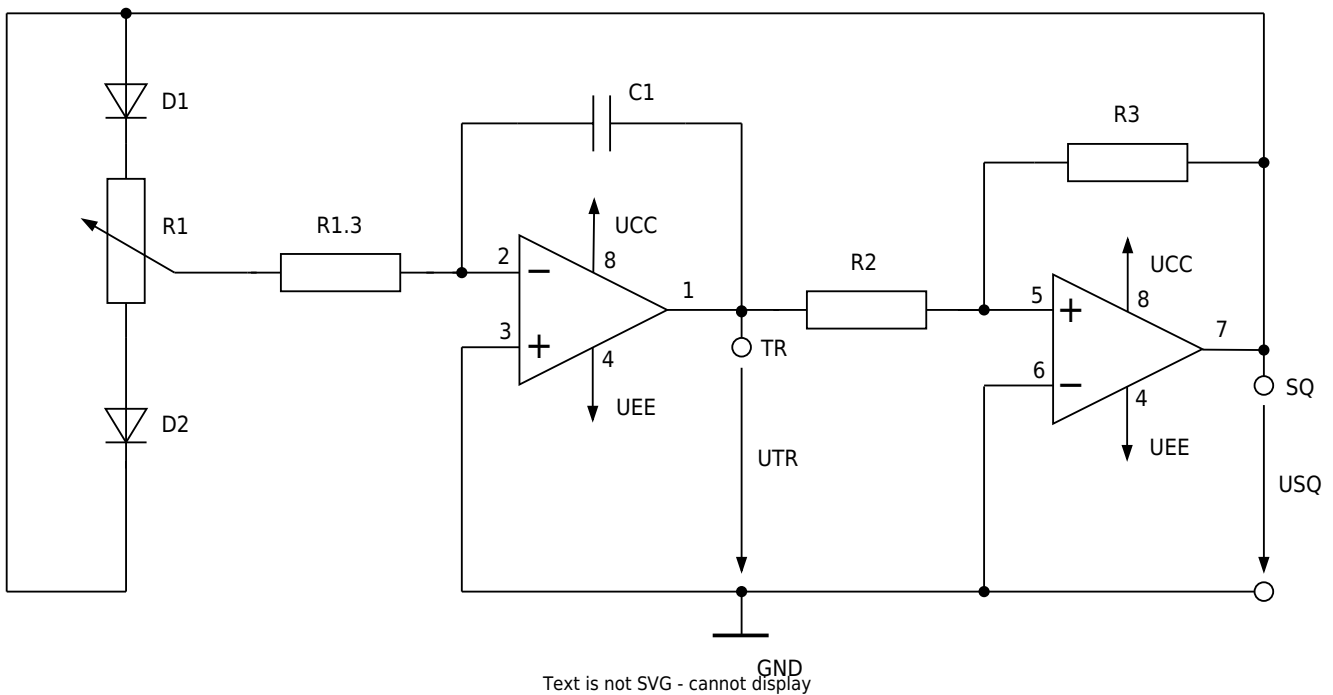

1. Build the circuit on the MEXLE-board. Connect channel 1 of the oscilloscope to TR and channel 2 to SQ. The duty cycle can be adjusted using R1. Perform the measurements for the minimum, maximum, and midpoint duty-cycle settings with the capacitances $C1 = 10\text{nF}$ and $C1 = 1\text{nF}$. Sketch the oscilloscope screen for each case.

C1 = 10 nF, minimum duty cycle

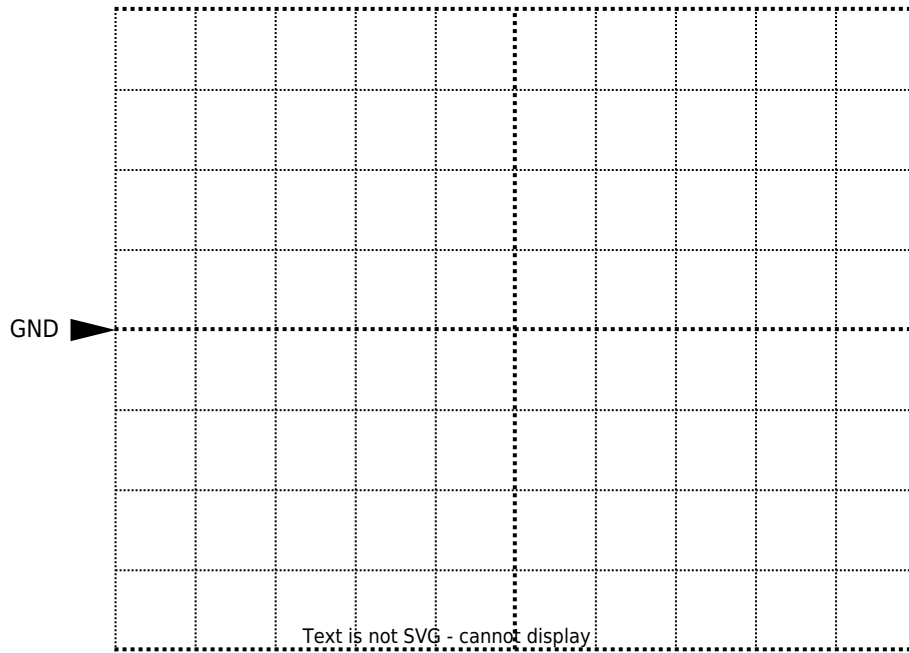

Channel 1: $\frac{\text{Volt}}{\text{Div}} = \$$

Channel 2: $\frac{\text{Volt}}{\text{Div}} = \$$

Time basis: $\frac{T}{\text{Div}} = \$$

C1 = 10 nF, maximum duty cycle

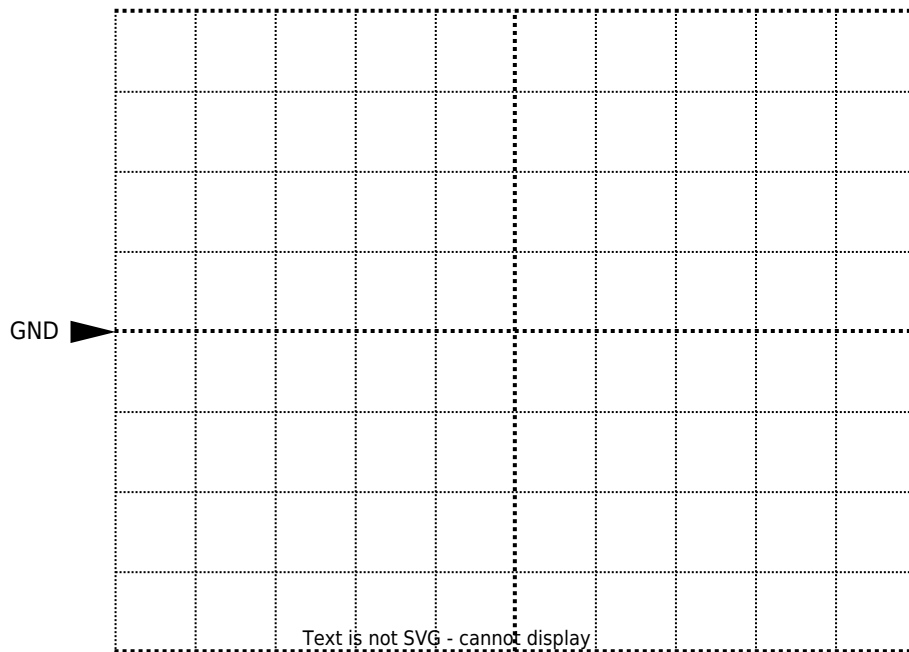

Channel 1: $\frac{\text{Volt}}{\text{Div}} = \$$

Channel 2: $\frac{\text{Volt}}{\text{Div}} = \$$

Time basis: $\frac{T}{Div} =$

C1 = 10 nF, middle position



Channel 1: $\frac{Volt}{Div} =$

Channel 2: $\frac{Volt}{Div} =$

Time basis: $\frac{T}{Div} =$

C1 = 1 nF, minimum duty cycle

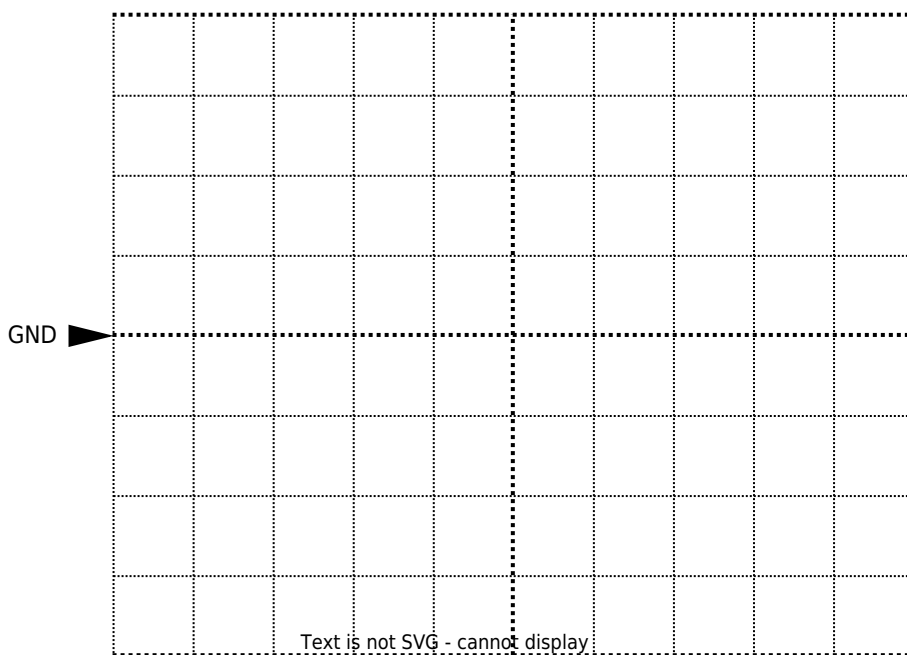

Channel 1: $\frac{Volt}{Div} =$

Channel 2: $\frac{Volt}{Div} =$

Time basis: $\frac{T}{Div} =$

C1 = 1 nF, maximum duty cycle

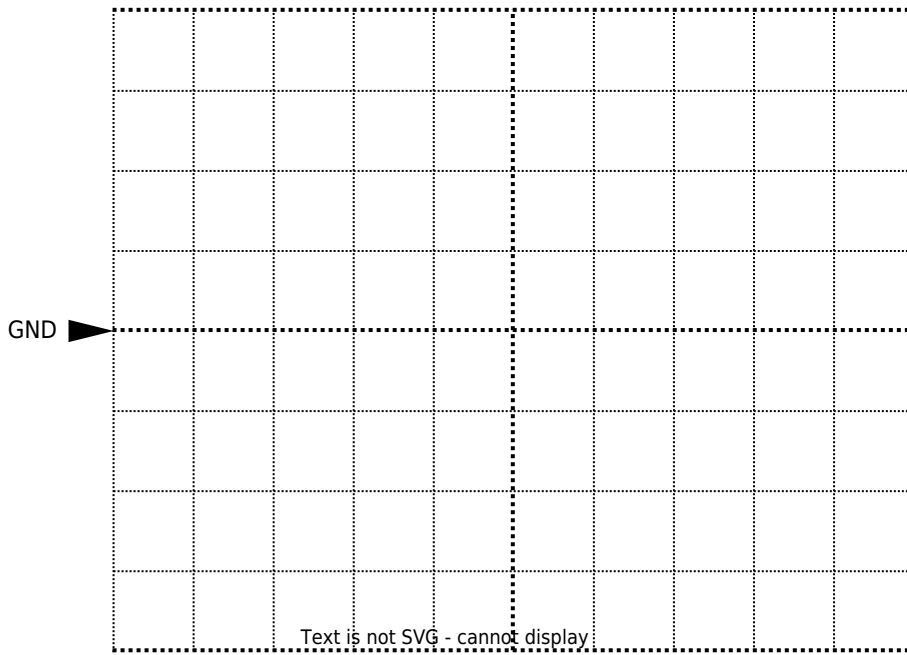

Channel 1: $\frac{Volt}{Div} =$

Channel 2: $\frac{Volt}{Div} =$

Time basis: $\frac{T}{Div} =$

C1 = 1 nF, middle position

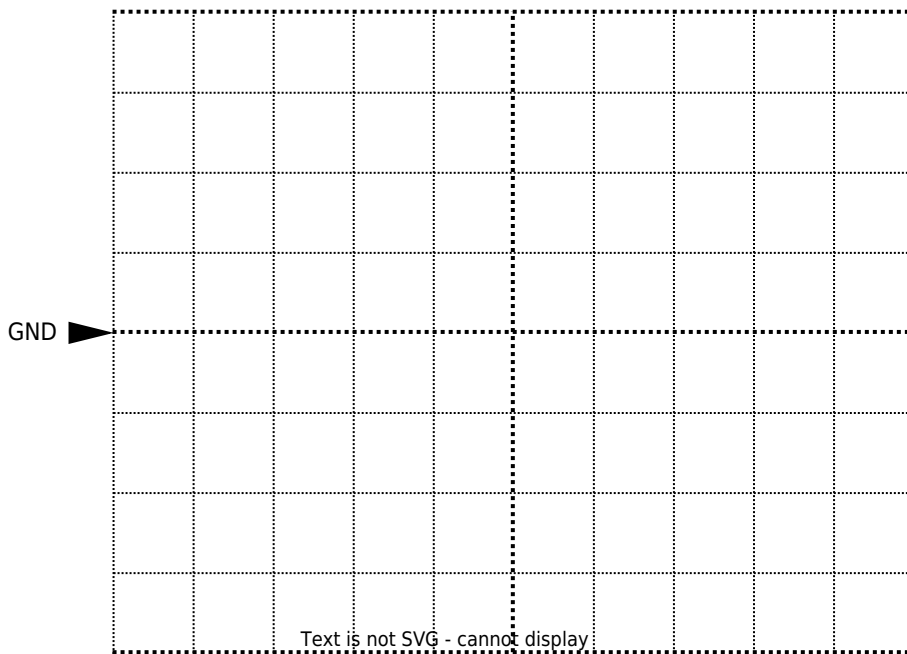

Channel 1: $\frac{Volt}{Div} =$

Channel 2: $\frac{Volt}{Div} =$

Time basis: $\frac{T}{Div} =$

2. Explain how this circuit works in a few sentences.

From:
<https://wiki.mexle.org/> - **MEXLE Wiki**

Permanent link:
https://wiki.mexle.org/lab_electrical_engineering/duty_cycle_adjustment?rev=1781693809

Last update: **2026/06/17 12:56**

