

Rectangular-to-Triangle Signal Conversion - Integrator

Student Group

First Name	Surname	Matrikel Nr.

Table of Contents

Rectangular-to-Triangle Signal Conversion - Integrator 2
 Background Information 2
 Experimental Tasks 3

Rectangular-to-Triangle Signal Conversion - Integrator

Background Information

The operation of an OPV in the linear operating range can be enforced by means of circuitry by feeding back the output signal, i.e., returning it to the inverting input (- input). In the circuit shown, the negative feedback is provided by a capacitor.

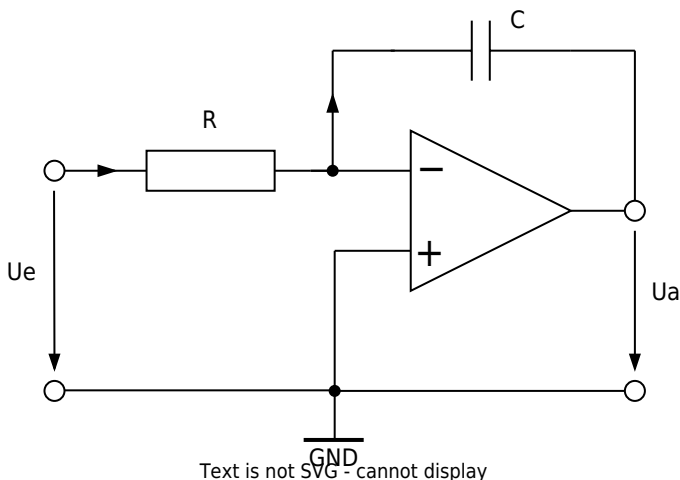

Analysis of the circuit:
Negative feedback

$$\rightarrow u_{\mathrm{d}} = 0 \rightarrow i_{\mathrm{R}} = \frac{u_{\mathrm{e}}}{R}$$

$$i_{\mathrm{R}} = i_{\mathrm{C}} \text{ (because OPV input current } i_{\mathrm{n}} = 0 \text{)}$$

$$u_{\mathrm{a}} = -u_{\mathrm{C}} = -\frac{1}{C} \int i_{\mathrm{C}} dt = -\frac{1}{RC} \int u_{\mathrm{e}} dt$$

The integrated input voltage appears at the output. The product of resistance and capacitance has the character of a time constant:

$$T_{\mathrm{i}} = RC$$

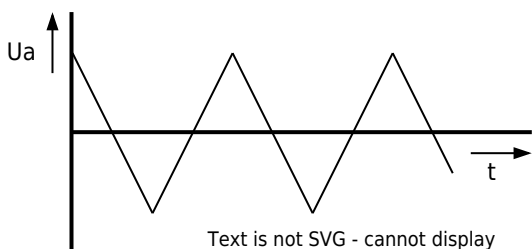
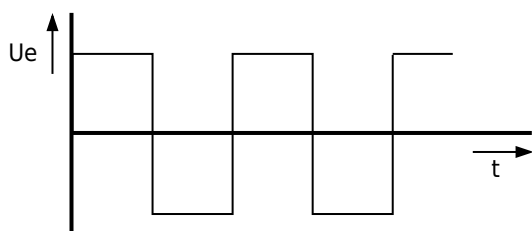

The figure shows the output voltage of an integrator with a square wave voltage at the input. The output voltage at the start $u_{\mathrm{a}}(t=0)$ depends on the charge state of the capacitor when switched on.

Experimental Tasks

To analyze the behavior of the integrator, the following circuit is used:

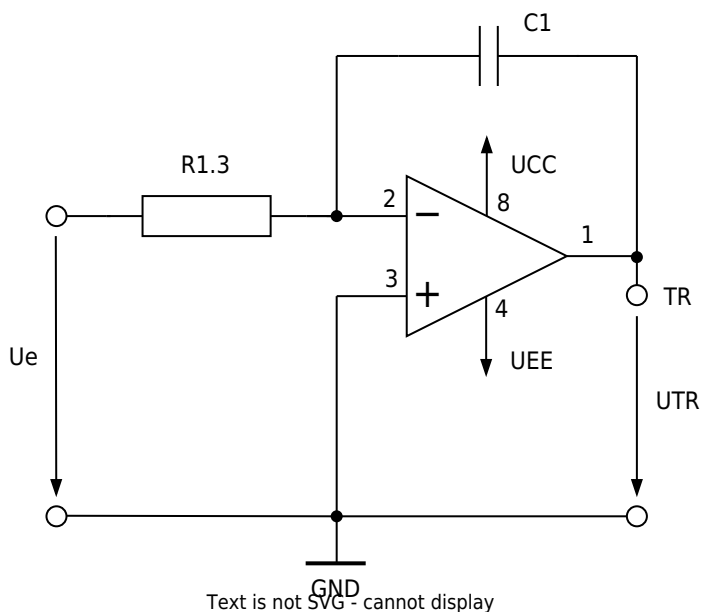

Supply voltages (from power supply unit):

$$U_{CC} = +3\text{ V}, U_{EE} = -3\text{ V}$$

Values of the components used:

$$R_{1.3} = 10\text{ k}\Omega, C_1 = 10\text{ nF}$$

1. Calculate the time constant T_{i} of the integrator from the given values.

2. Assumption: the capacitor is initially uncharged. A voltage $u_{\mathrm{e}} = +3\text{ V}$ is applied to the input.
How long does it take for the output voltage to reach $u_{\mathrm{Tr}} = -3\text{ V}$? Document your calculation.

3. Roughly sketch the voltage curves that you expect at the TR output when you apply a bipolar square wave signal to the u_{e} input.

Output TR

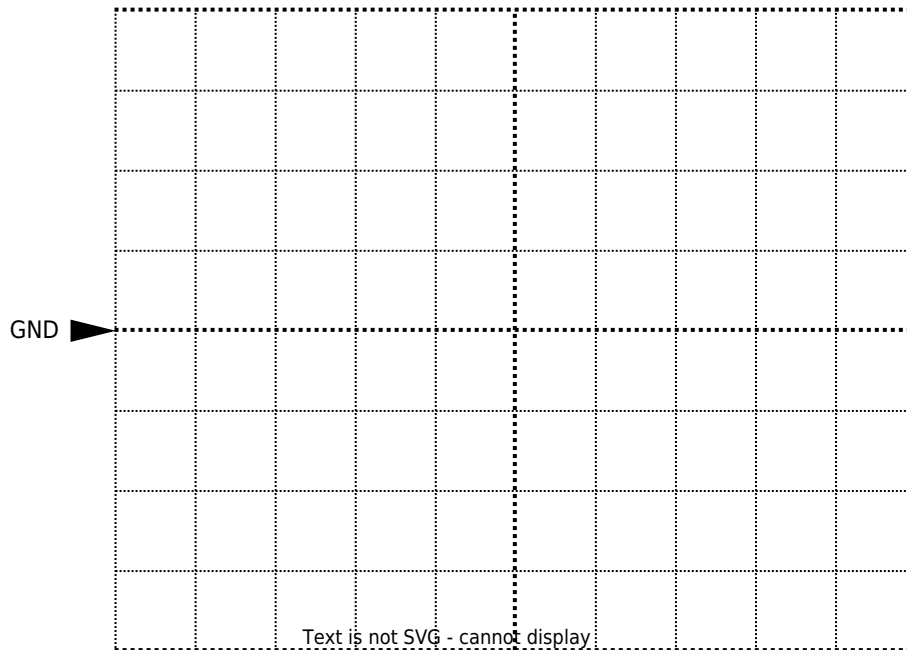

Channel 1: $\frac{\text{Volt}}{\text{Div}} = \$$

Time basis: $\frac{T}{\text{Div}} = \$$

4. Build the circuit on the MEXLE-board. Make sure that the jumper at the bottom of the op-amp is set to the left so that the op-amp is supplied with $\pm 3\text{V}$. Connect channel 1 on the oscilloscope to u_{e} and channel 2 to TR. Connect the function generator to the u_{e} input. Set to square wave (bipolar) with a frequency of 3kHz and a voltage of 3 V (amplitude). Switch on the power supply.

C1 = 10 nF, f = 3 kHz

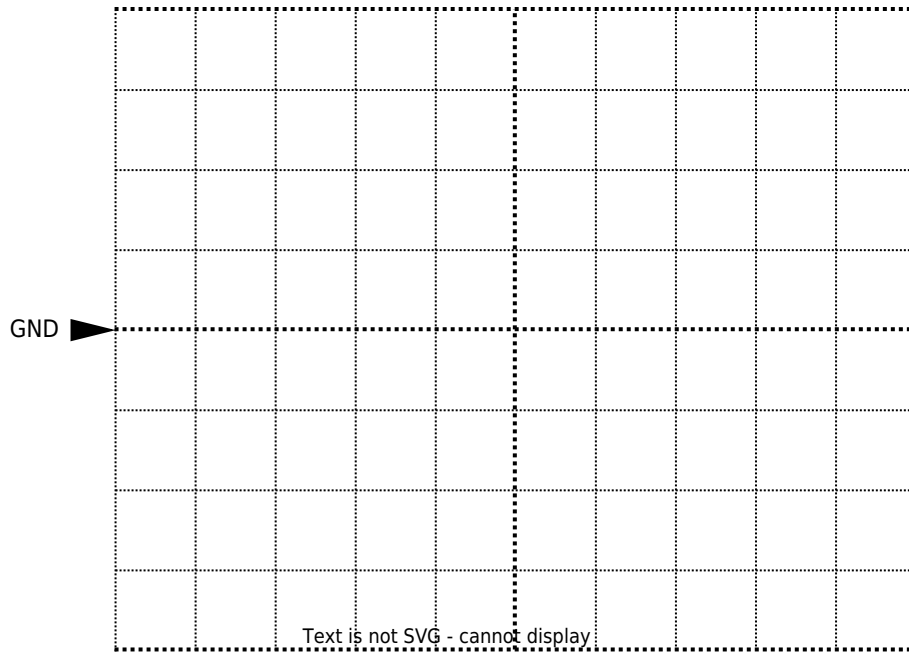

Channel 1: $\frac{\text{Volt}}{\text{Div}} = \$$

Channel 2: $\frac{\text{Volt}}{\text{Div}} = \$$

Time basis: $\frac{T}{\text{Div}} = \$$

5. Compare your measurement with the calculation from part 2 and the forecast from part 3. Explain your result.

From: <https://wiki.mexle.org/> - MEXLE Wiki

Permanent link: https://wiki.mexle.org/lab_electrical_engineering/rectangular-to-triangle_signal_conversion_integrator?rev=1781693220

Last update: 2026/06/17 12:47

